

仕 様 書

カトウ全油圧式オールテレールクレーン

KA-2200

キャリア：カトウ KA6350

クレーン部主要諸元

1. 名 称	220ton吊りオールテレーンクレーン	
2. 型 式	KA-2200	
3. クレーン性能		
最大定格総荷重		
・メインブーム	13.6 mブーム	※220.0t× 3.0m
	18.15mブーム	120.0t× 6.0m
	22.7 mブーム	120.0t× 6.0m
	31.8 mブーム	70.0t× 11.0m
	40.9 mブーム	60.0t× 12.0m
	45.5 mブーム	47.0t× 14.0m
	50.0 mブーム	35.0t× 18.0m
	最大作業半径時	7.2t× 46.0m
	※印は重荷重装置付	
・スーパーラフィングジブ	45.5mブーム+1.5m+10.5mSL	24.0t× 16.0m
(SLジブ)	50.0mブーム+1.5m+18.9mSL	10.0t× 30.0m
	50.0mブーム+1.5m+27.3mSL	7.0t× 30.0m
	最大作業半径時	2.0t× 62.0m
・ヘビーリフトジブ	13.6mブーム+4.4m+13.0mHL	84.0t× 9.0m
(HLジブ)	13.6mブーム+4.4m+22.0mHL	54.0t× 14.0m
	13.6mブーム+4.4m+31.0mHL	35.0t× 14.0m
	31.8mブーム+4.4m+40.0mHL	12.0t× 44.0m
	31.8mブーム+4.4m+47.0mHL	12.0t× 44.0m
	22.7mブーム+4.4m+54.0mHL	9.3t× 28.0m
	最大作業半径時	1.8t× 80.0m
最大地上揚程	ブーム	51.0m
	スーパーラフィングジブ	79.0m
	ヘビーリフトジブ	106.9m
巻上ロープ速度	主巻 (3層) 高速: 135m/min 低速: 80m/min 補巻 (3層) 高速: 135m/min 低速: 80m/min	
ブーム上げ時間	100s/-1.0°~ 83°	
ブーム伸長速度	13.6m ~ 50.0m/220s	
旋回速度	高速: 1.4min ⁻¹ 低速: 0.7min ⁻¹	

4. 上部旋回体の装置及び構造

メインブーム	箱型5段油圧伸縮式 13.6m ~ 50.0m
スーパーラフィングジブ	1.5mベースブラケット+箱型3段油圧伸縮式 10.5m ~ 27.3m オフセット: 5° ~ 60°
ヘビーリフトジブ	4.4mベースブラケット+トラス式 13.0m ~ 54.0m オフセット: 10° ~ 60°
巻上装置	油圧モータ駆動、平歯車+遊星歯車2段減速式、自動ブレーキ付、 高低速切換装置付、圧力補償付流量調整弁付、シングルウインチ2基
旋回装置	油圧モータ駆動、遊星歯車減速機付 (ネガティブブレーキ内蔵)×2 フリー・ロック切換式、高低速切換式
旋回サークル	ローラーベアリング式、Cリング上下分割式
旋回後端半径	4,440mm (カウンタウエイト無し)
ロープ (主巻) (補巻)	φ24×360m φ24×360m
カウンタウエイト	60t・40t・25t・10t
運転室	ラバーマウント式キャブ、キャブチルト装置付

5. アウトリガ

形式	油圧垂直支持式 (サイドサポート併用)
張出幅	9,400 mm (最大張出) 8,400 mm (中間張出) 7,400 mm (中間張出) 6,400 mm (中間張出) 5,400 mm (中間張出)

6. クレーン用エンジン

名 称	三菱 6D24-TE1
型 式	水冷4サイクル直列6気筒 直接噴射式ディーゼルエンジン ターボ付
総排気量	11.94L
最大出力	188kW (255PS)/1,800min ⁻¹
最大トルク	1,079N・m (110kgf・m)/1,400min ⁻¹
燃料タンク容量	300L
電気システム	24V
バッテリー	115F51×2

7. 油圧装置	
オイルポンプ	2連斜軸型バリアブルピストンポンプ+2連ギヤポンプ
オイルモータ	巻上用 斜板型2速ピストンモータ 旋回用 斜板型ピストンモータ
コントロールバルブ	マルチプル自動復元式 (圧力補償付流量調整弁付)
シリンダ	ダブルアクティング式
オイルリザーバ	1,700L
8. 安全装置	ACS (全自動過負荷防止装置、音声警報装置付)、作業範囲制限装置 アウトリガ張出幅自動検出装置、旋回位置検出装置、過巻防止装置 ブーム自然降下防止装置、ドラムロック装置、ドラム回転計、 ドラムホールド安全装置、自動ブレーキ装置、乱巻防止装置、 油圧安全弁、アウトリガロック装置、旋回ロック装置、ACS外部表示灯、 風速計、スタンション、旋回音声警報
9. 標準装置	エアーコンディショナ、オイルクーラ、AM/FMラジオ、 作業灯、リモコン式サーチライト、ドラム監視カメラ 間欠付フロント&天井ワイパー (ウォッシャー付)、 ロール式サンバイザー、ランチテーブル、ステップランプ、 フロアカーペット、シガーライター、 パワーウインドウ (閉め忘れ防止スイッチ付)、ホット&クールボックス、 消火器
10. オプション装置	拡声器、ドアバイザ

キャリヤ部主要諸元

1. 車名及び型式	カトウ KA6350
2. 走行性能 (台車のみ)	
最高速度	75km/h
登坂能力	0.5 (tan θ)
最小回転半径	11.6m
3. 寸法・重量 (台車のみ)	
全 長	14,710mm
全 幅	3,000mm
全 高	2,820mm
軸 距	2,770+1,950+1,650+1,700+1,650=9,720mm
輪 距	前 輪 2,500mm 後 輪 2,500mm
乗車定員	2人
車両総重量	全重量 42,740kg 前 軸 16,580kg (1軸+2軸) 後 軸 26,160kg (3軸+4軸+5軸+6軸)
4. エンジン	
名 称	ベンツ OM502LA
型 式	水冷4サイクルV型8気筒 電子制御ディーゼルエンジン (インタークーラターボ付)
総排気量	15.928L
最大出力	390kW (530PS)/1,800min ⁻¹
最大トルク	2,400N・m (245kgf・m)/1,080min ⁻¹
電気システム	24V
バッテリー	145G51×2

5. 下部走行体の装置及び構造

走行駆動形式	8輪駆動 (12×8)
トルクコンバータ形式	3要素 1段 (自動ロックアップクラッチ付)
変速機型式	フルオートマチック (流体式リターダ付)
変速段数	前進5段 後退1段 副変速機 (High-Low切換付)
車軸型式	第1軸 逆エリオット式 (ステア) 第2軸 全浮動式 (ドライブ、ステア、減速機、デフロック付) 第3軸 逆エリオット式 (ステア) 第4軸 全浮動式 (ドライブ、減速機、デフロック、インターアクスルデフロック付) 第5軸 全浮動式 (ドライブ、ステア、減速機、デフロック、 インターアクスルデフロック付) 第6軸 全浮動式 (ドライブ、ステア、減速機、デフロック付)
懸架装置	ハイドロニューマチックサスペンション (サスペンションロック機構付)
ブレーキ装置	
主ブレーキ	2系統空気式全輪制動
駐車ブレーキ	空気式車輪制動形スプリングブレーキ (3, 4, 5, 6軸)
補助ブレーキ	エンジンブレーキ (圧縮ブレーキ)、排気ブレーキ、流体式リターダ
非常ブレーキ	駐車ブレーキと兼用
ステアリング装置 形式	セミインテグラル式パワーステアリング 非常用パワーステアリング付 1, 2, 3軸—同位相操向 5, 6軸—逆位相操向
タイヤサイズ 前輪	445/95 R25 177E ROAD
後輪	445/95 R25 177E ROAD
燃料タンク容量	500L

6. 安全装置

緊急用かじ取装置、オーバーラン警報装置、3点式シートベルト (運転席)、サスペンションロック装置、電動式サイドミラー (左側)、警告反射板、エンジン電子制御装置、トランスミッション電子制御装置、ラジエター液面警報装置、ローエア警報装置、後方確認カメラ、ブレーキランプ・スモールランプ断線警報装置

7. 標準装置
- チルト/テレスコピックステアリングホイール、エアコンディショナ、パワーウィンドウ、サスペンション付マルチアジャスタブルシート、タコグラフ、サンバイザー、集中給脂装置、エアドライヤ、AM/FMラジオ、前後牽引フック

※本仕様は、改良などにより予告なく変更する事があります。

【注意】

1. 本機は公道走行をする場合、旋回体およびブームを別送し台車のみで走行しなければなりません。
2. 道路を通行する場合には、道路法により通行の許可と道路運送車両法による保安基準の緩和が必要です。
3. 本機は道路法による基本通行条件のC条件相当車です。
4. 構内を移動する時に限り、構内走行姿勢図のような状態で移動できます。
ただし、走行速度は25km/h以下で走行してください。
5. クレーンの旋回体にカウンタウエイトを装着しているときは、必ずアウトリガを使用した状態にしてください。

■全体図

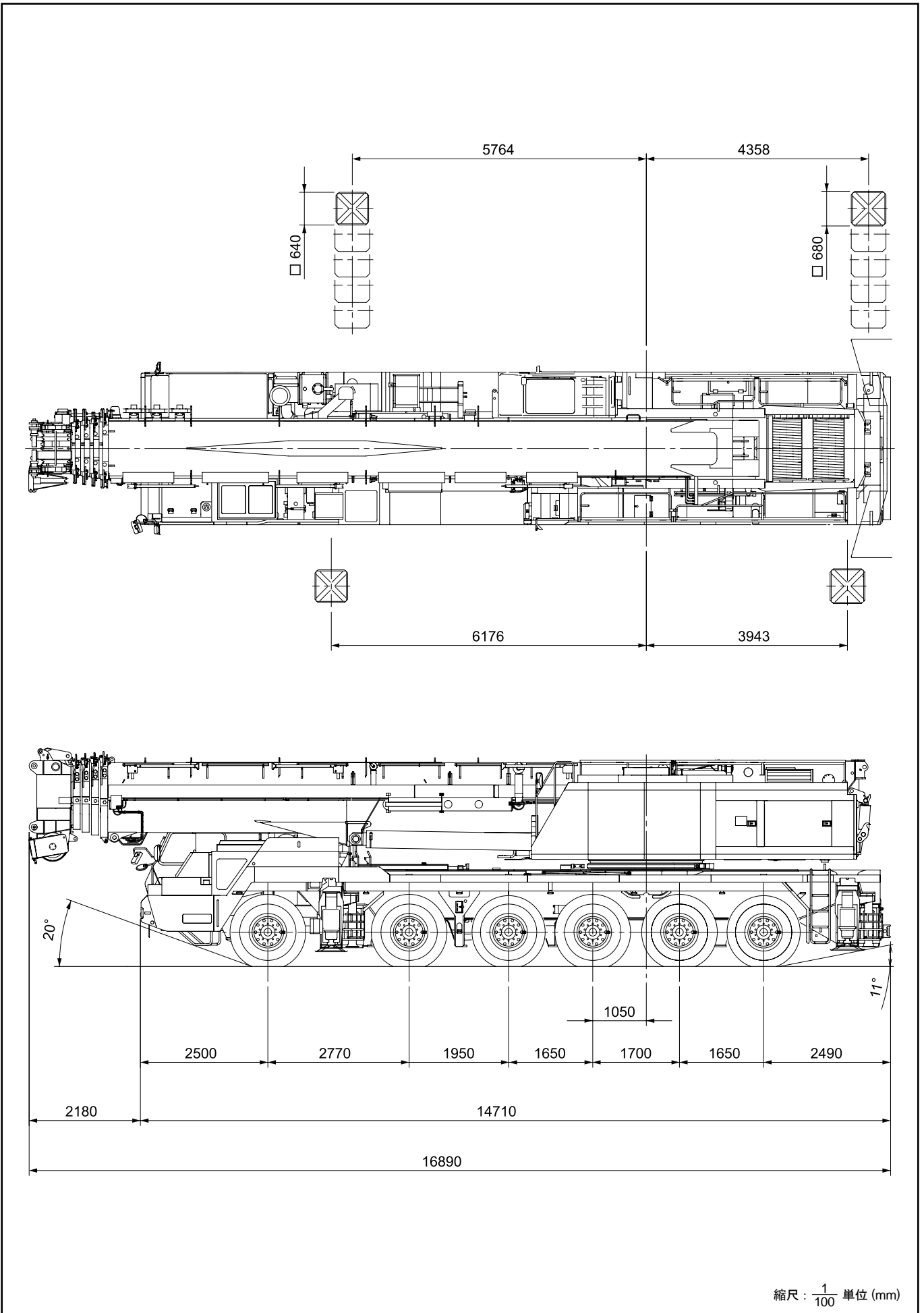

■全体図

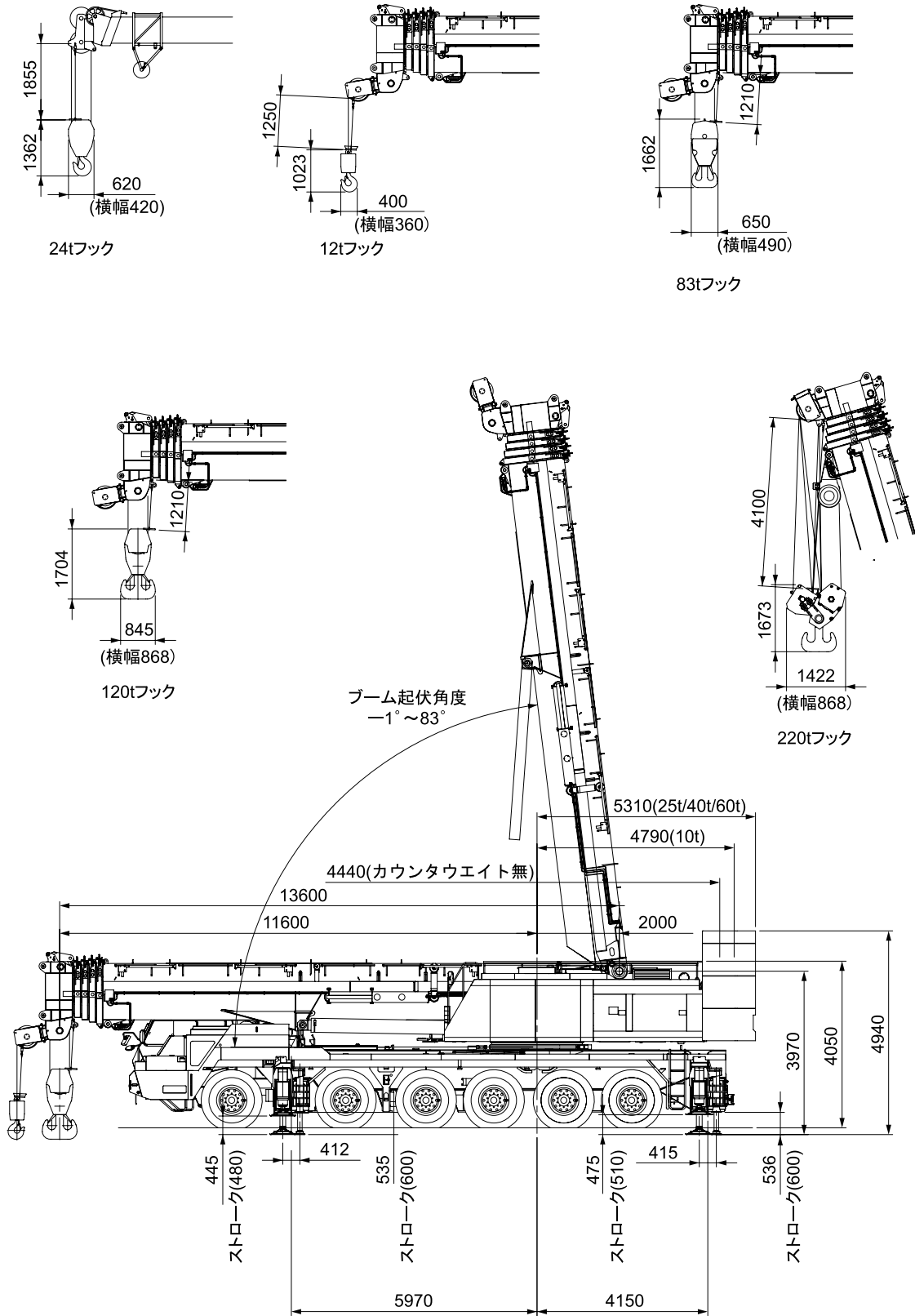

縮尺: $\frac{1}{150}$ 単位(mm)

■全体図

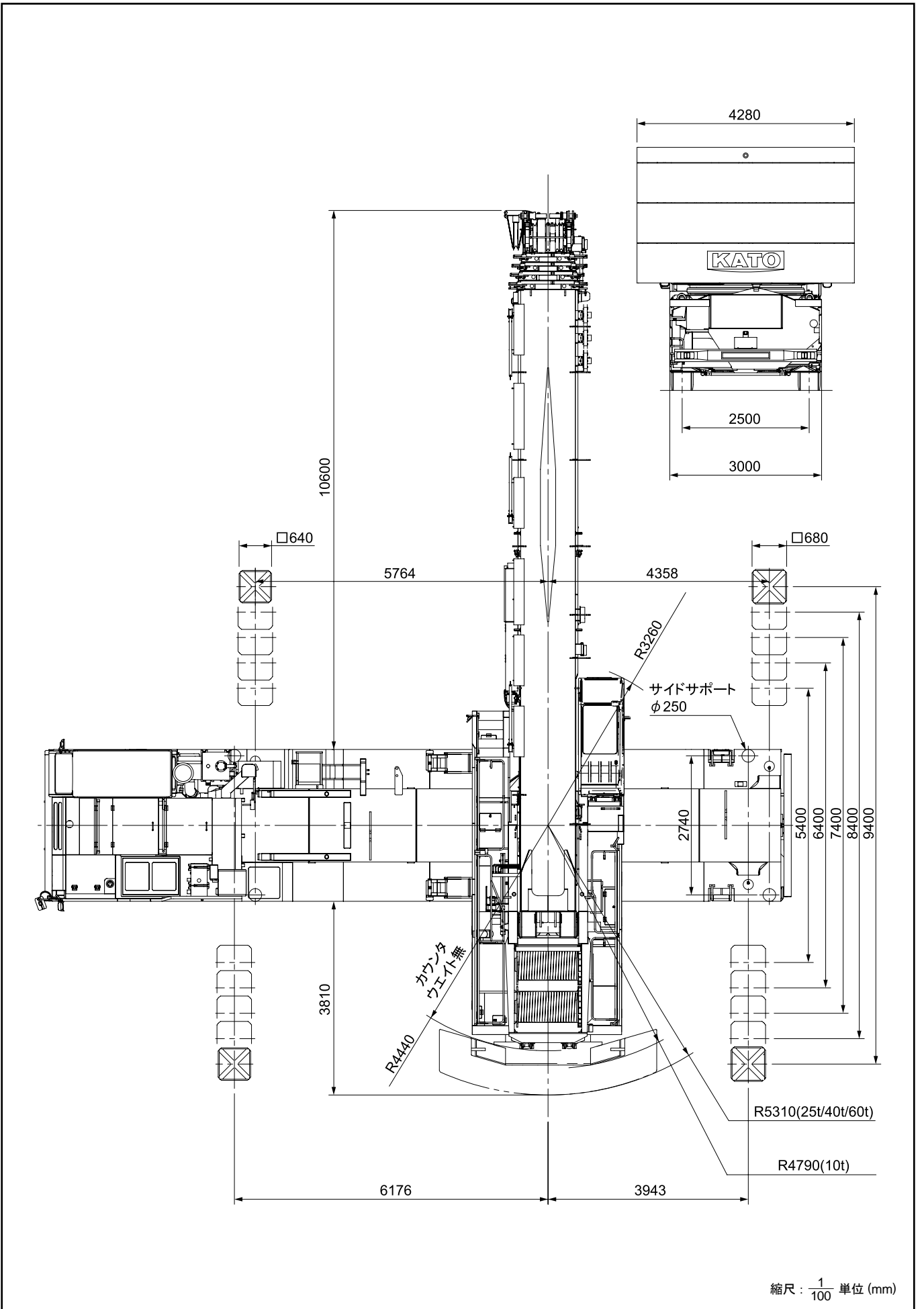

■最小直角通路幅

●構内走行時

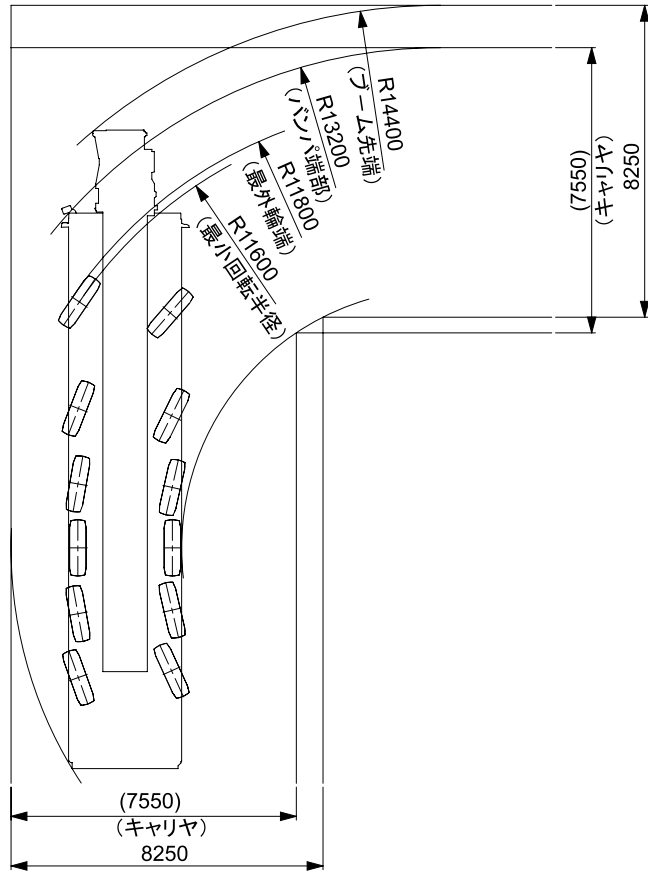

■公道走行状態

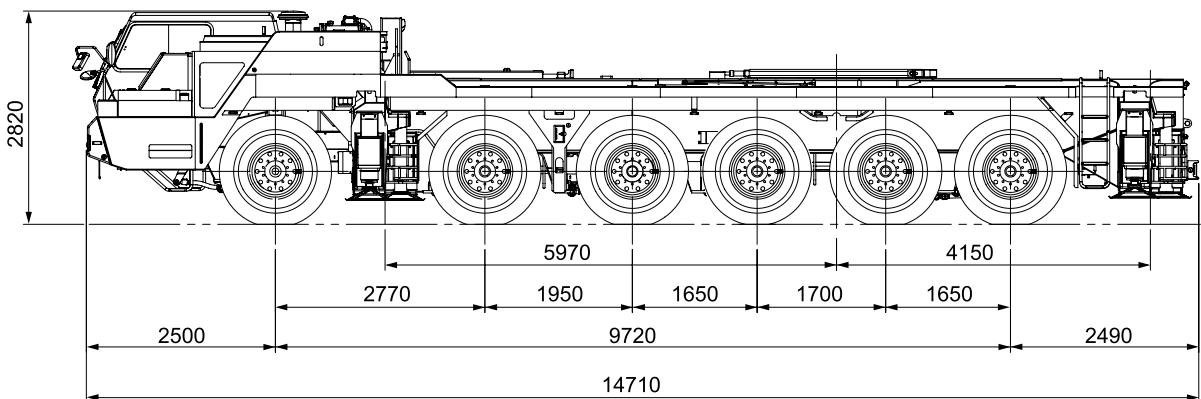
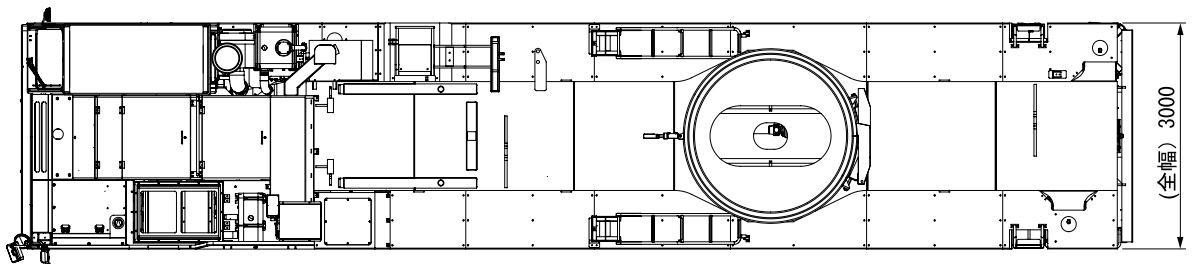

縮尺: $\frac{1}{100}$ 単位 (mm)

■寸法・重量関係

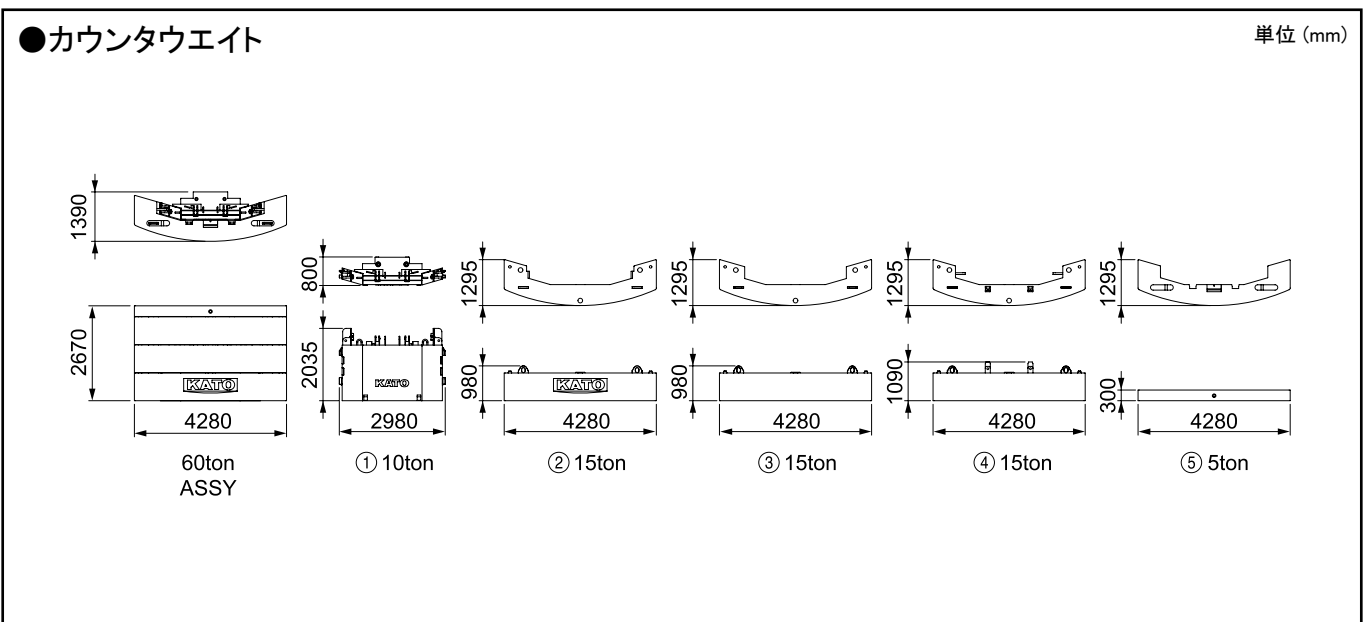
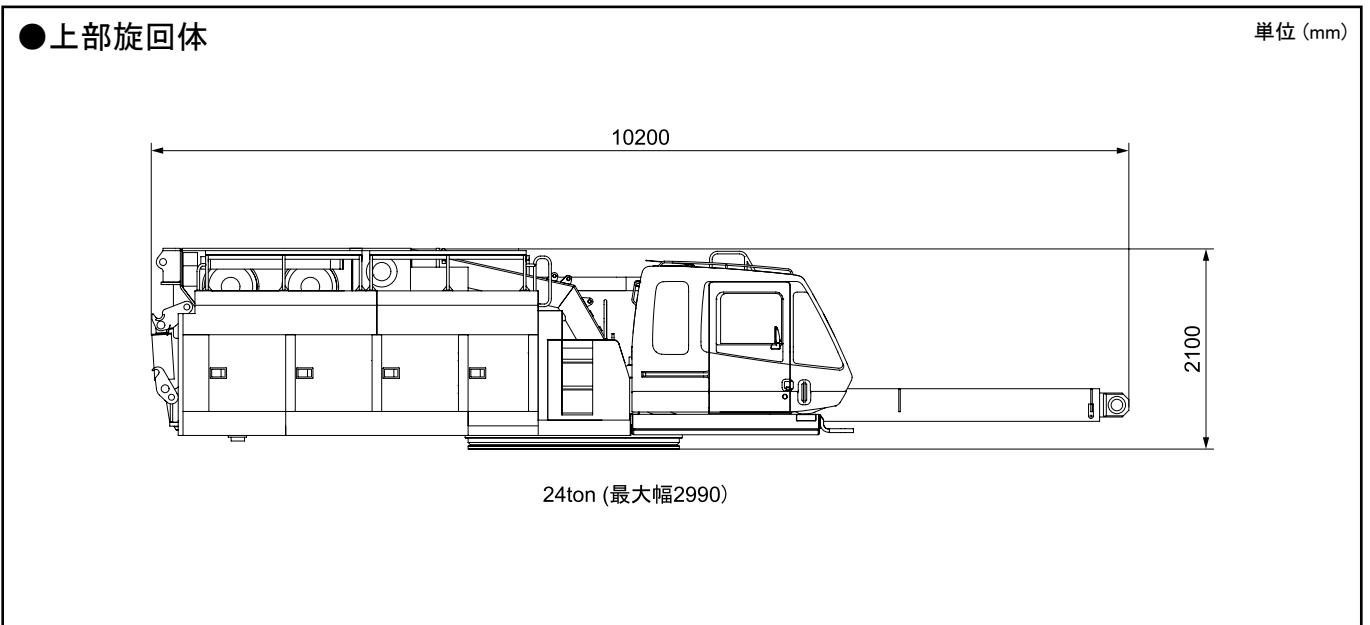
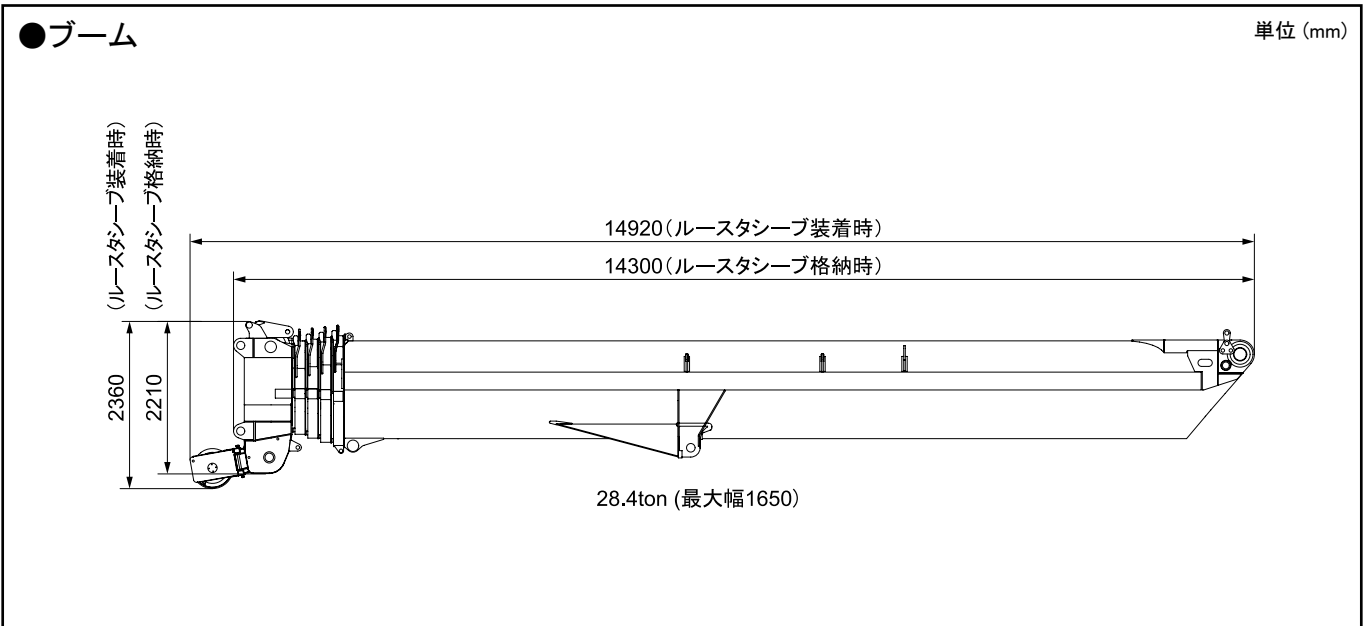

重荷重吊り上げ装置付 作業範囲図

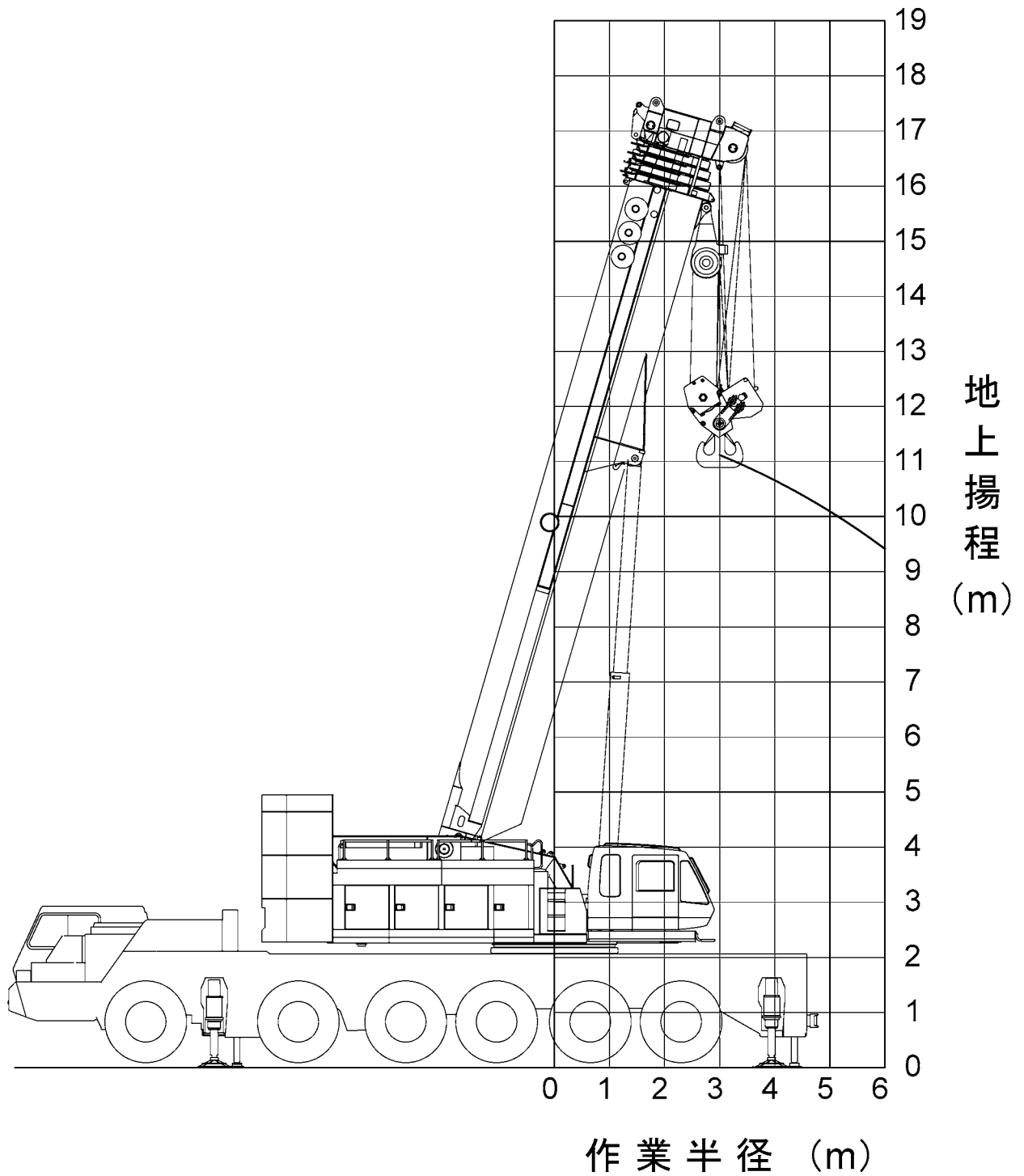

注) 本図は、ブームのたわみを含んでいません。

ブーム・ルースターシーブ 作業範囲図 【通常伸縮】

- | | | | |
|------------|------------|---------------------|---------------------|
| Ⓐ13.6m ブーム | ⓓ31.8m ブーム | ⓓ13.6m ブーム+ルースターシーブ | ⓓ18.15mブーム+ルースターシーブ |
| Ⓑ18.15mブーム | ⓔ40.9m ブーム | ⓔ18.15mブーム+ルースターシーブ | ⓔ22.7m ブーム+ルースターシーブ |
| Ⓒ22.7m ブーム | ⓕ45.5m ブーム | ⓕ31.8m ブーム+ルースターシーブ | ⓕ40.9m ブーム+ルースターシーブ |
| Ⓓ31.8m ブーム | ⓖ50.0m ブーム | ⓖ45.5m ブーム+ルースターシーブ | ⓖ50.0m ブーム+ルースターシーブ |

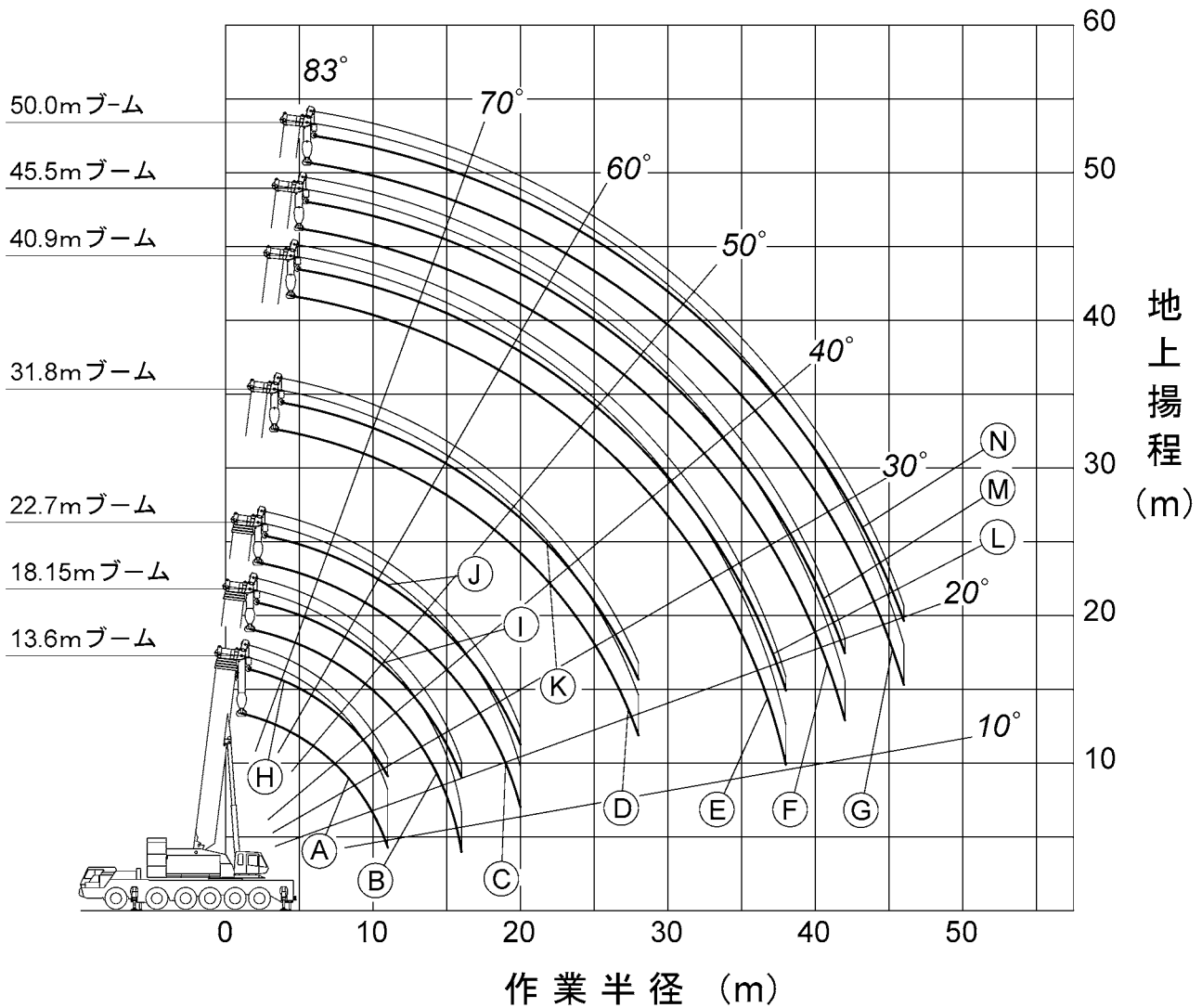

注) 1. 本図は、ブームのたわみを含んでいません。
2. A1～A3、B1性能の最大作業半径を図示しています。

ブーム・ルースターシーブ 作業範囲図 【特殊伸縮】

- Ⓐ13.6m ブーム
- Ⓑ18.15mブーム
- Ⓒ22.7m ブーム
- Ⓓ31.8m ブーム
- Ⓔ40.9m ブーム
- Ⓕ13.6m ブーム+ルースターシーブ
- Ⓖ18.15mブーム+ルースターシーブ
- Ⓗ22.7m ブーム+ルースターシーブ
- Ⓘ31.8m ブーム+ルースターシーブ
- Ⓧ40.9m ブーム+ルースターシーブ

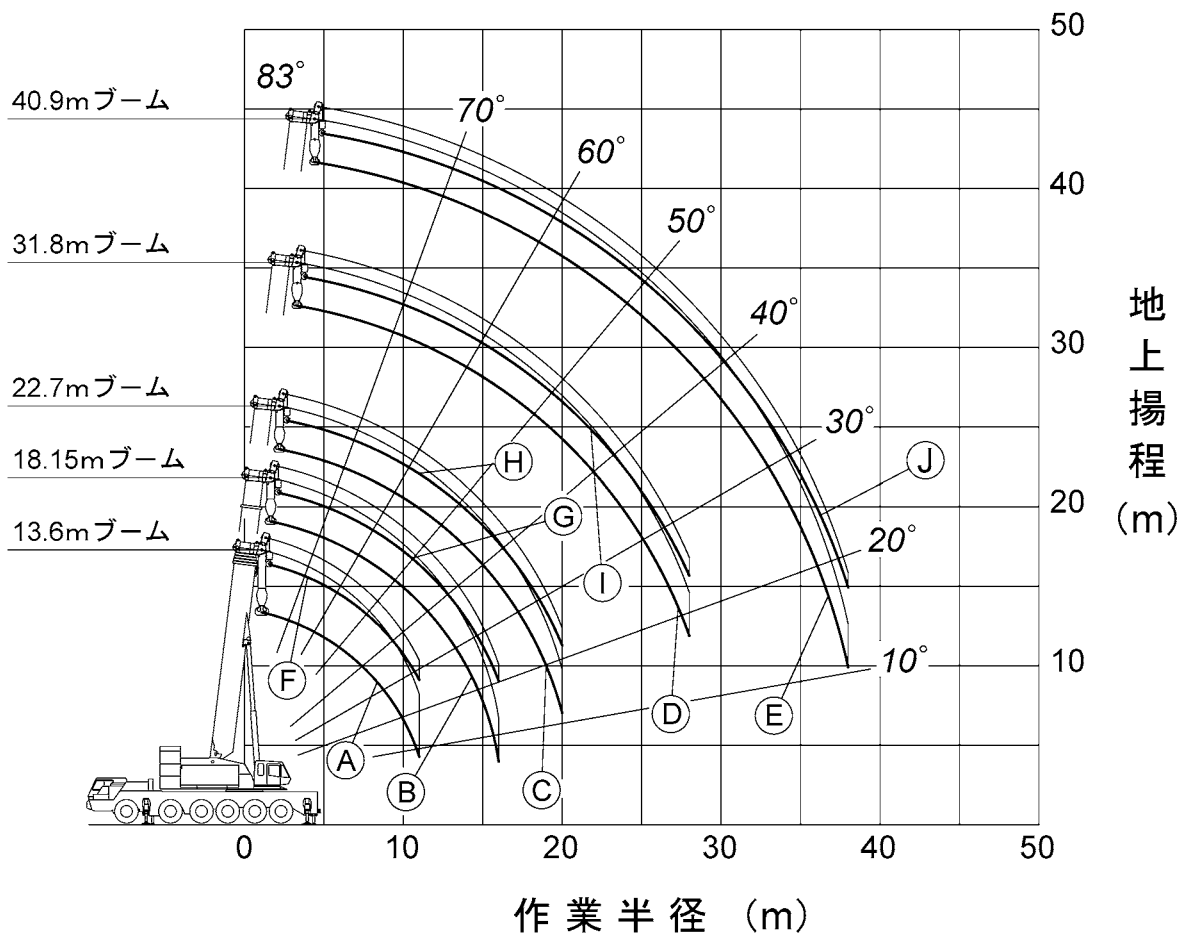

- 注) 1. 本図は、ブームのたわみを含んでいません。
2. TA1 ~ TA4、TB1 ~ TB4、TC1 ~ TC2性能の最大作業半径を図示しています。

スーパーラフィングジブ(SLジブ) 作業範囲図 【40.9mブーム時】

40.9mブーム+1.5m+10.5mSLジブ (オフセット 5°~ 60°)
 40.9mブーム+1.5m+18.9mSLジブ (オフセット 5°~ 60°)
 40.9mブーム+1.5m+27.3mSLジブ (オフセット 5°~ 60°)

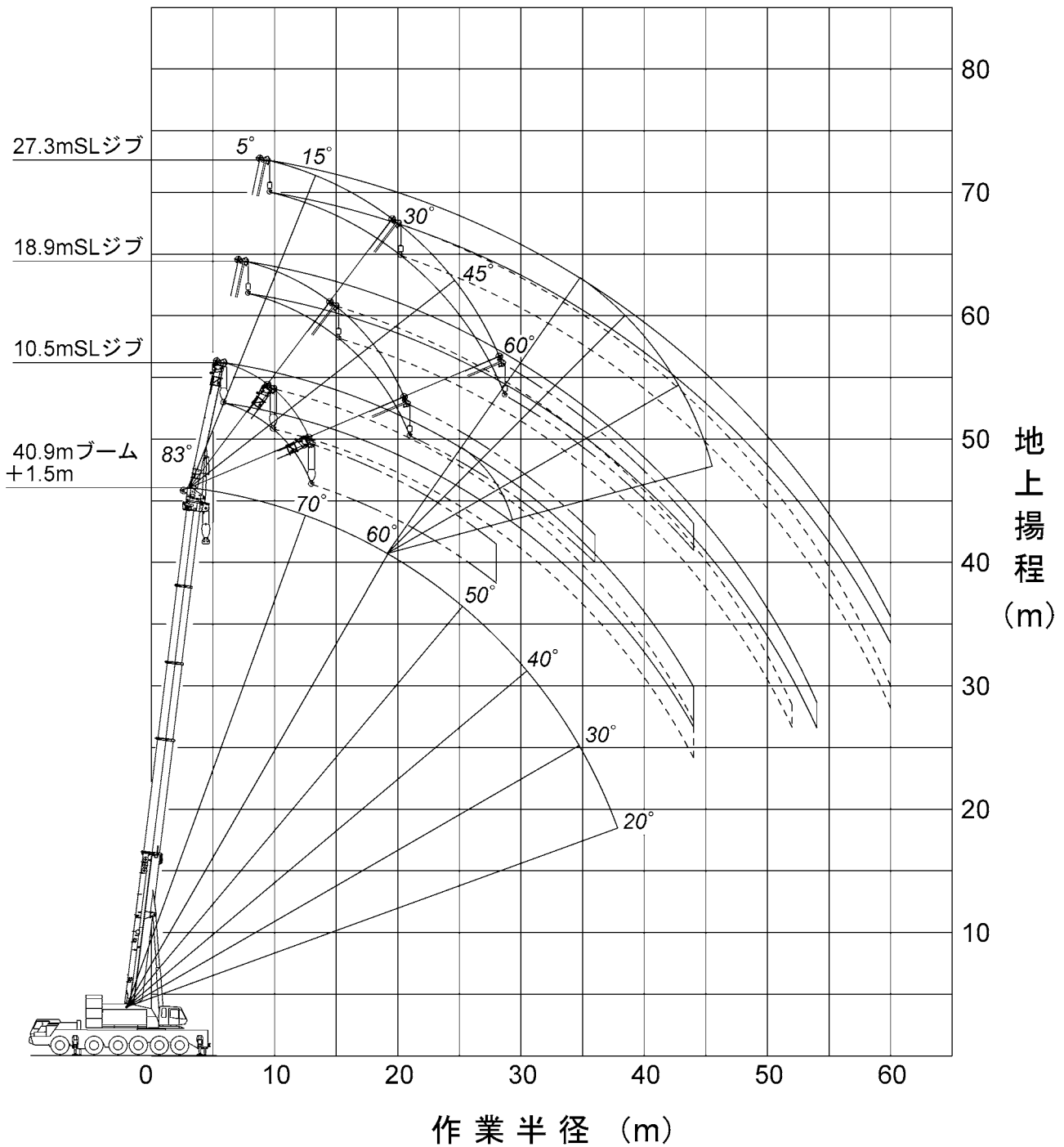

注) 1. 本図は、ブームおよびSLジブのたわみを含んでいません。
 2. SS性能の最大作業半径を図示しています。

スーパーラフィングジブ(SLジブ) 作業範囲図 【45.5mブーム時】

45.5mブーム+1.5m+10.5mSLジブ (オフセット5°~60°)
 45.5mブーム+1.5m+18.9mSLジブ (オフセット5°~60°)
 45.5mブーム+1.5m+27.3mSLジブ (オフセット5°~60°)

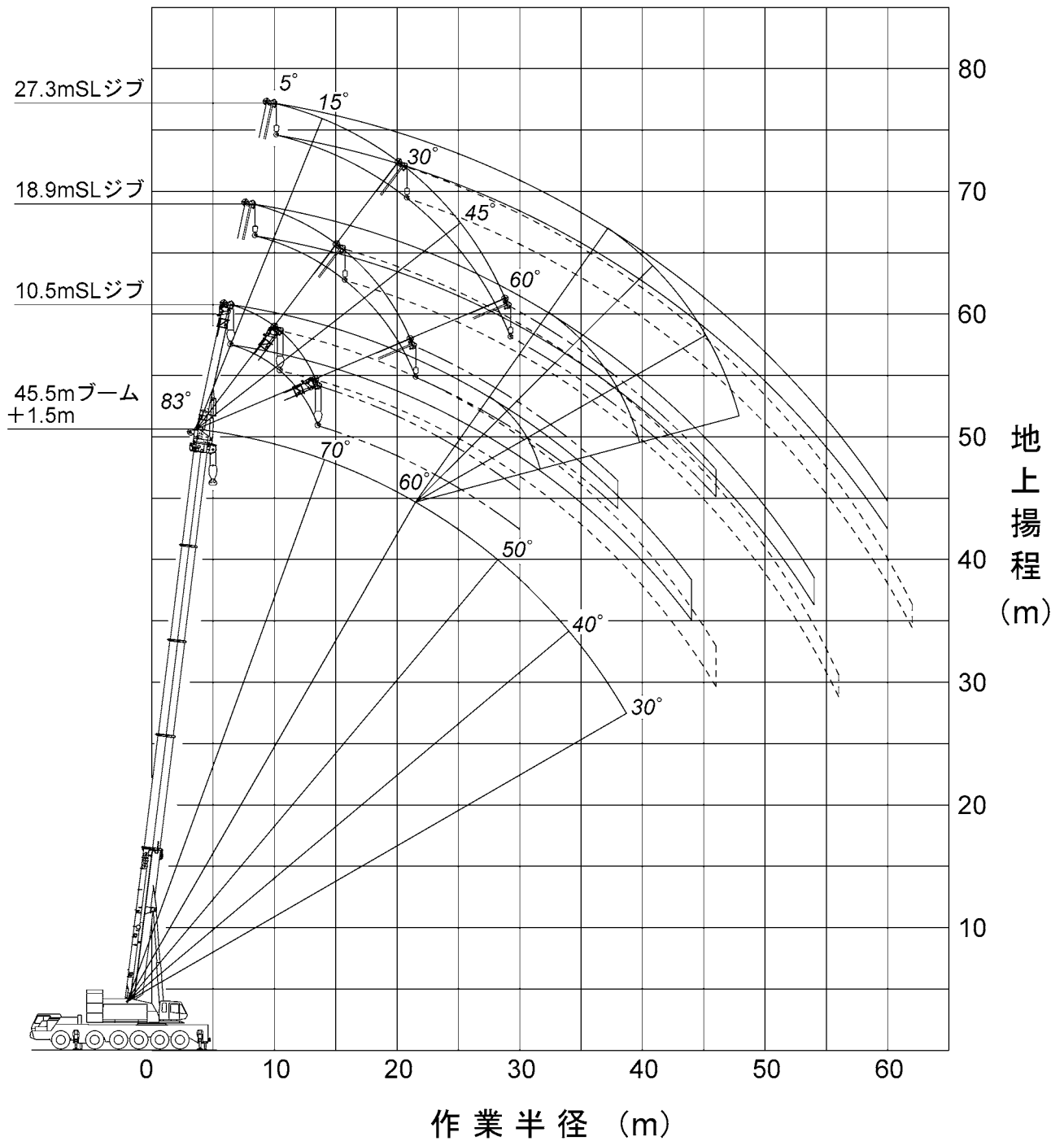

注) 1. 本図は、ブームおよびSLジブのたわみを含んでいません。
 2. SS性能の最大作業半径を図示しています。

スーパーラフィングジブ(SLジブ) 作業範囲図 【50mブーム時】

50.0mブーム+1.5m+10.5mSLジブ (オフセット5°~60°)
 50.0mブーム+1.5m+18.9mSLジブ (オフセット5°~60°)
 50.0mブーム+1.5m+27.3mSLジブ (オフセット5°~60°)

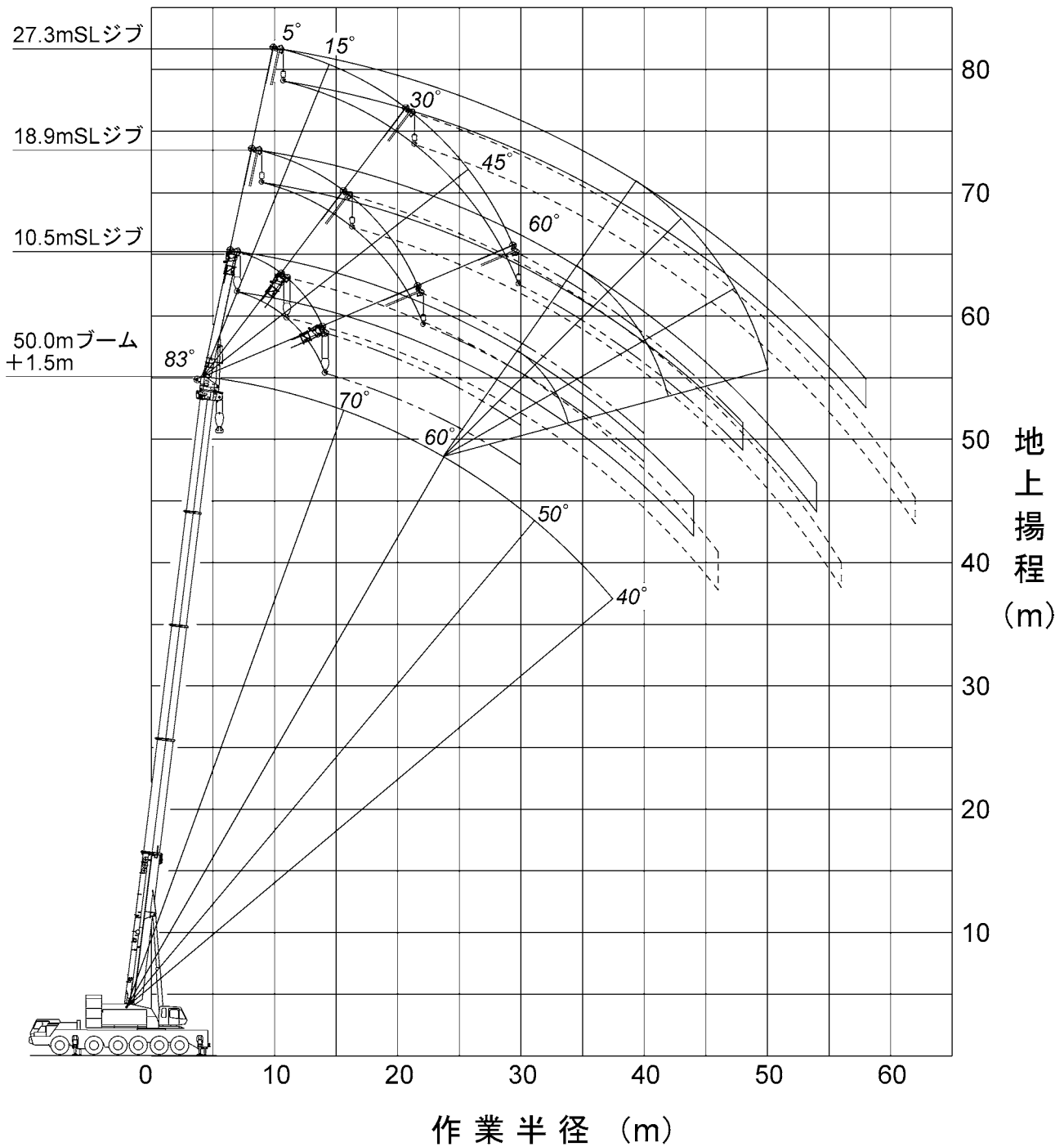

注) 1. 本図は、ブームおよびSLジブのたわみを含んでいません。
 2. SS性能の最大作業半径を図示しています。

ヘビーリフトジブ(HLジブ) 作業範囲図

- | | | | |
|---|---------------------------------------|---|-----------------------------------------|
| Ⓐ | 13.6mブーム+4.4m+13mヘビーリフトジブ (オフセット 10°) | Ⓜ | 50.0mブーム+4.4m+22mSLヘビーリフトジブ (オフセット 10°) |
| Ⓑ | +22mヘビーリフトジブ (オフセット 10°) | Ⓝ | +31mSLヘビーリフトジブ (オフセット 10°) |
| Ⓒ | +31mヘビーリフトジブ (オフセット 10°) | Ⓓ | +40mSLヘビーリフトジブ (オフセット 10°) |
| Ⓓ | +40mヘビーリフトジブ (オフセット 10°) | Ⓔ | +47mSLヘビーリフトジブ (オフセット 10°) |
| Ⓔ | +47mヘビーリフトジブ (オフセット 10°) | Ⓕ | +54mSLヘビーリフトジブ (オフセット 10°) |
| Ⓕ | +54mヘビーリフトジブ (オフセット 10°) | Ⓖ | +22mSLヘビーリフトジブ (オフセット 60°) |
| Ⓖ | +13mヘビーリフトジブ (オフセット 60°) | Ⓖ | +31mSLヘビーリフトジブ (オフセット 60°) |
| Ⓕ | +22mヘビーリフトジブ (オフセット 60°) | Ⓖ | +40mSLヘビーリフトジブ (オフセット 60°) |
| Ⓕ | +31mヘビーリフトジブ (オフセット 60°) | Ⓖ | +47mSLヘビーリフトジブ (オフセット 60°) |
| Ⓕ | +40mヘビーリフトジブ (オフセット 60°) | Ⓖ | +54mSLヘビーリフトジブ (オフセット 45°) |
| Ⓕ | +47mヘビーリフトジブ (オフセット 60°) | | |
| Ⓕ | +54mヘビーリフトジブ (オフセット 60°) | | |

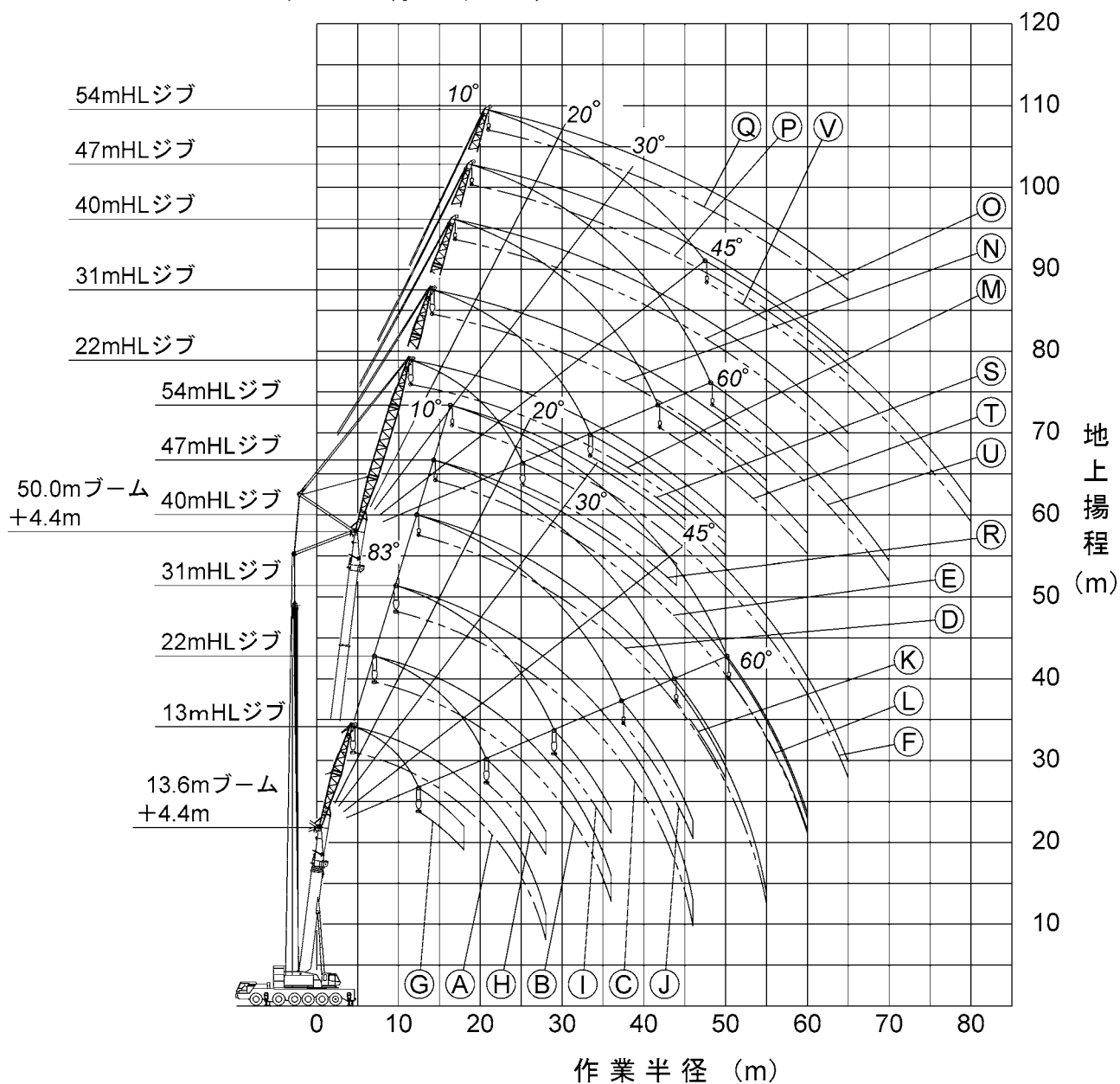

- 注) 1. 本図は、ブームおよびヘビーリフトジブのたわみを含んでいません。
 2. HA性能の最大作業半径を図示しています。

定格総荷重表注意事項

- 1) 定格総荷重は水平堅土上において本機の保証できる最大荷重を示しており、フックその他つり具等の質量を含んだ値です。なお、太枠の内側は、機械の強度によって定められ、下側は機械の安定度によって定められています。
- 2) 定格総荷重は、アウトリガ・サイドサポート・ブームロックを使用した状態で、アウトリガの張出幅とカウンタウエイトの装備状態により、次のように区分されます。
- 3) 各ブーム条件において吊方向が前方・後方時は、側方性能がある場合アウトリガ張出幅最大の状態と同じ性能になります。

ブーム <重荷重> 【全周・後方】

吊方向	カウンタウエイト	
	アウトリガ張出幅	
全周*	7.4m	AA

*最大荷重は後方のみ

※重荷重装置付

ブーム <通常伸縮>

吊方向	カウンタウエイト					
	アウトリガ張出幅					
		60t	40t	25t	10t	0t
側方	9.4m	A1	B1	C1	D1	E1
	8.4m	A2	B2	C2	D2	E2
	7.4m	A3	B3	C3	D3	E3
	6.4m	A4	B4	C4	D4	E4
	5.4m	—	B5	C5	D5	E5

ブーム <特殊伸縮>

吊方向	カウンタウエイト					
	アウトリガ張出幅					
		60t	40t	25t	10t	0t
側方	9.4m	TA1	TB1	TC1	TD1	TE1
	8.4m	TA2	TB2	TC2	TD2	TE2
	7.4m	TA3	TB3	TC3	TD3	TE3
	6.4m	TA4	TB4	TC4	TD4	TE4
	5.4m	—	TB5	TC5	TD5	TE5

特殊伸縮：2段ブームを伸ばさずに、3、4、5段ブームを等長で伸縮させる伸縮方式です。

スーパーラフィングジブ

吊方向	カウンタウエイト					
	アウトリガ張出幅					
		60t	40t	25t	10t	0t
側方	9.4m	SS	SB	SC	SD	SE
	8.4m	SA	SC	SD	SE	—
7.4m	SB	—		—	—	

ヘビーリフトジブ

吊方向	カウンタウエイト			
	アウトリガ張出幅			
		60t	40t	25t
側方	9.4m	HA	HB	HC
	8.4m	HB	HC	—
7.4m	—			

4) 前方領域及び後方領域の範囲を下記に示します。

作業状態	重荷重	通常
領域α	15°	15°
領域β	5°	15°

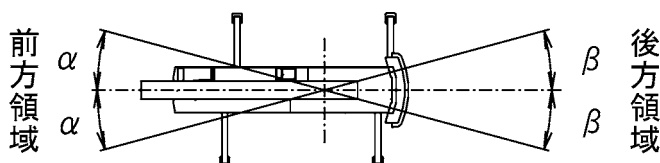

- 5) 定格総荷重のブーム角度は、ブームと水平面のなす角度を示し、ジブ角度はブームとジブのなす角度を示します。
- 6) 作業半径は、ブームのたわみを含んだ実際値に基づいていますので必ず作業半径を基準として作業を行ってください。但しスーパーラフィングジブの作業半径は、40.9mブーム・45.5mブーム・50.0mブームにスーパーラフィングジブを装着してジブ作業を行った時の値を示し、これより短いブーム長さでのジブ作業はジブを40.9mブームに取り付けた時のブーム角度だけを基準として行ってください。
- 7) ブーム長さ・ブーム角度・作業半径・ジブ角度が規定の値を超えた場合は、その規定の値と次の規定の値の定格総荷重のうち小さい方の定格総荷重に従って作業を行ってください。
- 8) 定格総荷重表の危険角度は、それ以下にブームを下げると無負荷でもクレーンが転倒したり、機械の破損につながる角度を示します。
- 9) スーパーラフィングジブを装着したままでブーム作業（通常伸縮）を行う場合は、ブームの定格総荷重表よりつり具の質量の他にブーム長さに応じて下表の荷重を差し引いてください。
なお、スーパーラフィングジブを装着したままでのブーム作業は、ブーム状態が通常伸縮時に限ります。

ブーム長さ	13.6m	18.15m	22.7m	31.8m	40.9m	45.5m	50.0m
差引荷重	23t			17t			

- 10) ルースタシーブの定格総荷重は、ブーム定格総荷重と等しく、かつ、限度を12tonとします。
但し、ブームにつり具等が取り付けられている場合には、定格総荷重よりつり具の質量の他にブームに取り付けられているつり具等の質量も差し引いてください。
- 11) ヘビーリフトジブ31mの単索時定格総荷重は、ヘビーリフトジブ31mの定格総荷重と等しく、かつ、限度を12tonとします。
- 12) ヘビーリフトジブの起伏用ロープは、6本掛にしてください。
- 13) 作業状態別標準フックの種類・掛数・質量を次に示します。

なお、下表12tonフック使用にあたり、ヘビーリフトジブ作業時にはサブウエイト有（530kg）ブーム作業（ルースタシーブ）・スーパーラフィングジブ作業時にはサブウエイト無（420kg）のフックを使用してください。

フック種類	220t	120t	83t	24t	12t	
フック質量	2520kg	1900kg	1000kg	880kg	サブウエイト無/有	
					420kg	530kg

ブーム【通常伸縮】

ブーム長さ	13.6m重荷重	13.6m	18.15m	22.7m	31.8m	40.9m	45.5m	50.0m
フック種類	220t	120t	120t	120t	83t	83t	83t	83t
掛数	10x2	12	12	12	7	6	4	4

ブーム【特殊伸縮】

ブーム長さ	13.6m	18.15m	22.7m	31.8m	40.9m
フック種類	120t	83t	83t	83t	83t
掛数	12	7	7	6	4

ルースタシーフ

フック種類	12t
掛数	1

スーパーラフィングジブ

SL長さ	10.5m	18.9m	27.3 m
フック種類	24t	12t	12t
掛数	2	1	1

ヘビーリフトジブ

ブーム長さ	HL長さ	13.0m	22.0m	31.0m	40.0m	47.0m	54.0m
13.6m	フック種類	120t	83t	83t (12t)	12t	12t	12t
	掛数	8	6	4 (1)	1	1	1
18.15m	フック種類	120t	83t	83t (12t)	12t	12t	12t
	掛数	8	6	4 (1)	1	1	1
22.7m	フック種類	83t	83t	83t (12t)	12t	12t	12t
	掛数	6	4	4 (1)	1	1	1
31.8m	フック種類	83t	83t	24t (12t)	12t	12t	12t
	掛数	4	4	2 (1)	1	1	1
40.9m	フック種類	—	24t	24t (12t)	12t	12t	12t
	掛数	—	2	2 (1)	1	1	1
45.5m	フック種類	—	24t	24t (12t)	12t	12t	12t
	掛数	—	2	2 (1)	1	1	1
50.0m	フック種類	—	24t	24t (12t)	12t	12t	12t
	掛数	—	2	2 (1)	1	1	1

- 14) クレーン作業は風速10m/sまで可能ですが、比較的弱い風の場合でも受風面積の大きい荷重を取扱う場合は特別な注意を払ってください。
- 15) 定格総荷重表以外の仕事を行った場合及び正しい使い方をしなかった時は、転倒又は破損します。この場合は本機の保証はいたしません。
- 16) 本仕様は改良等により予告なく変更する事があります。

メインブーム (アウトリガ 9.4m)

(単位 : ton)

作業半径 (m)	13.6m ブーム					18.15m ブーム					22.7m ブーム					31.8m ブーム					
	性能区分					性能区分					性能区分					性能区分					
	A1	B1	C1	D1	E1	A1	B1	C1	D1	E1	A1	B1	C1	D1	E1	A1	B1	C1	D1	E1	
3.0	120.0	120.0	120.0	120.0	120.0																
3.5	120.0	120.0	120.0	120.0	120.0	120.0	120.0	120.0	120.0	120.0											
4.0	120.0	120.0	120.0	120.0	120.0	120.0	120.0	120.0	120.0	120.0	120.0	120.0	120.0	120.0							
4.5	120.0	120.0	120.0	120.0	120.0	120.0	120.0	120.0	120.0	120.0	120.0	120.0	120.0	120.0							
5.0	120.0	120.0	120.0	120.0	116.7	120.0	120.0	120.0	120.0	115.0	120.0	120.0	120.0	120.0	113.7	70.0	70.0	70.0	70.0	70.0	
6.0	120.0	119.9	113.9	102.1	94.6	120.0	118.6	112.4	100.4	92.9	120.0	117.6	111.1	99.1	91.6	70.0	70.0	70.0	70.0	70.0	
7.0	112.2	104.3	95.5	85.2	78.8	110.8	103.0	93.8	83.6	77.1	109.8	102.0	92.6	82.3	75.9	70.0	70.0	70.0	70.0	70.0	
8.0	99.1	90.6	81.6	72.6	67.0	97.6	88.9	79.9	70.9	65.3	96.6	87.7	78.7	69.7	64.1	70.0	70.0	70.0	70.0	66.7	
9.0	88.4	78.8	70.8	62.8	57.1	86.9	77.1	69.1	61.1	54.9	85.9	75.9	67.9	59.9	53.3	70.0	70.0	70.0	62.5	56.5	
10.0	79.6	69.4	62.2	55.0	45.6	78.1	67.7	60.5	53.3	43.6	76.9	66.4	59.3	52.1	42.1	70.0	69.0	61.8	54.6	45.2	
11.0	71.3	61.7	55.2	46.3	37.3	69.5	60.0	53.4	44.4	35.2	68.3	58.7	52.2	43.0	33.7	70.0	61.2	54.7	45.8	36.8	
12.0						62.3	53.5	47.5	37.2	28.7	61.1	52.3	46.3	35.9	27.3	63.5	54.8	48.8	38.6	30.1	
14.0						51.4	43.5	36.9	27.0	19.9	50.2	42.2	35.6	25.7	18.6	52.1	44.6	38.0	28.2	21.2	
16.0						41.6	36.0	28.7	20.2	14.3	41.8	34.7	27.5	18.8	13.0	43.6	37.1	29.7	21.2	15.4	
18.0											35.2	28.5	21.7	14.1	9.0	37.5	30.7	23.8	16.3	11.4	
20.0											29.5	23.4	17.3	10.7		32.0	25.4	19.3	12.7	8.3	
22.0																28.0	21.3	15.8	9.9	5.5	
24.0																24.3	18.0	13.0	7.5	3.4	
26.0																21.0	15.4	10.8	5.4		
28.0																18.6	13.2	8.9	3.6		
30.0																					
32.0																					
34.0																					
36.0																					
38.0																					
40.0																					
42.0																					
44.0																					
46.0																					
危険角度 (°)	-	-	-	-	-	-	-	-	-	-	-	-	-	-	-	-	-	-	-	-	33
フック種類	120t					120t					120t					83t					
フック質量 (t)	1.90					1.90					1.90					1.00					
巻掛本数	12					12					12					7					

メインブーム (アウトリガ 9.4m)

作業半径 (m)	40.9m ブーム					45.5m ブーム					50.0m ブーム				
	性能区分					性能区分					性能区分				
	A1	B1	C1	D1	E1	A1	B1	C1	D1	E1	A1	B1	C1	D1	E1
3.0															
3.5															
4.0															
4.5															
5.0															
6.0															
7.0	60.0	60.0	60.0	60.0	60.0										
8.0	60.0	60.0	60.0	60.0	60.0	47.0	47.0	47.0	47.0	47.0	35.0	35.0	35.0	35.0	35.0
9.0	60.0	60.0	60.0	60.0	52.9	47.0	47.0	47.0	47.0	47.0	35.0	35.0	35.0	35.0	35.0
10.0	60.0	60.0	60.0	55.4	43.8	47.0	47.0	47.0	47.0	42.3	35.0	35.0	35.0	35.0	35.0
11.0	60.0	60.0	55.8	47.1	36.8	47.0	47.0	47.0	46.4	35.8	35.0	35.0	35.0	35.0	35.0
12.0	60.0	55.9	49.9	39.8	31.4	47.0	47.0	47.0	40.1	30.6	35.0	35.0	35.0	35.0	30.3
14.0	52.1	45.8	39.2	29.4	22.4	47.0	46.1	39.5	29.8	22.7	35.0	35.0	35.0	30.4	22.9
16.0	44.7	38.2	30.8	22.3	16.5	42.9	38.5	31.1	22.6	16.8	35.0	35.0	31.6	23.2	17.4
18.0	38.1	31.7	24.8	17.4	12.4	38.2	31.9	25.1	17.7	12.7	35.0	32.4	25.6	18.2	13.3
20.0	32.8	26.3	20.3	13.7	9.4	33.1	26.6	20.6	14.0	9.7	31.4	27.1	21.1	14.5	10.2
22.0	28.5	22.2	16.8	10.9	6.8	28.8	22.5	17.0	11.2	7.2	28.3	22.9	17.5	11.6	7.8
24.0	24.9	18.9	13.9	8.7	4.6	25.1	19.2	14.2	8.9	5.0	25.7	19.6	14.7	9.4	5.6
26.0	22.0	16.3	11.6	6.6		22.1	16.5	11.9	6.9		22.6	16.9	12.3	7.5	3.7
28.0	19.7	14.0	9.8	4.8		20.1	14.3	10.0	5.1		19.9	14.7	10.4	5.6	
30.0	17.5	12.2	8.1	3.2		17.7	12.4	8.4	3.6		18.1	12.8	8.8	4.1	
32.0	15.5	10.6	6.5			15.7	10.8	6.8			16.1	11.1	7.3		
34.0	13.8	9.2	5.1			14.0	9.4	5.4			14.3	9.7	5.9		
36.0	12.3	7.9	3.9			12.4	8.1	4.2			12.8	8.5	4.6		
38.0	11.0	6.6				11.1	6.8	3.1			11.4	7.2	3.5		
40.0						10.0	5.7				10.2	6.1			
42.0						8.9	4.7				9.2	5.0			
44.0											8.2	4.1			
46.0											7.2	3.3			
危険角度 (°)	-	-	-	36	47	-	-	23	43	52	7	11	32	47	56
フック種類	83t					83t					83t				
フック質量 (t)	1.00					1.00					1.00				
巻掛本数	6					4					4				

メインブーム (アウトリガ 8.4m)

(単位 : ton)

作業半径 (m)	13.6m ブーム					18.15m ブーム					22.7m ブーム					31.8m ブーム				
	性能区分					性能区分					性能区分					性能区分				
	A2	B2	C2	D2	E2	A2	B2	C2	D2	E2	A2	B2	C2	D2	E2	A2	B2	C2	D2	E2
3.0	120.0	120.0	120.0	120.0	120.0															
3.5	120.0	120.0	120.0	120.0	120.0	120.0	120.0	120.0	120.0	120.0										
4.0	120.0	120.0	120.0	120.0	120.0	120.0	120.0	120.0	120.0	120.0	120.0	120.0	120.0	120.0						
4.5	120.0	120.0	120.0	120.0	120.0	120.0	120.0	120.0	120.0	120.0	120.0	120.0	120.0	120.0						
5.0	120.0	120.0	120.0	120.0	116.7	120.0	120.0	120.0	120.0	115.0	120.0	120.0	120.0	120.0	113.7	70.0	70.0	70.0	70.0	70.0
6.0	120.0	119.9	113.9	102.1	94.6	120.0	118.6	112.4	100.4	92.9	120.0	117.6	111.1	99.1	91.6	70.0	70.0	70.0	70.0	70.0
7.0	112.2	104.3	95.5	85.2	78.8	110.8	103.0	93.8	83.6	77.1	109.8	102.0	92.6	82.3	75.9	70.0	70.0	70.0	70.0	70.0
8.0	99.1	90.6	81.6	72.6	61.8	97.6	88.9	79.9	70.9	59.3	96.6	87.7	78.7	69.7	57.4	70.0	70.0	70.0	70.0	56.0
9.0	88.4	78.8	70.8	59.5	46.6	86.9	77.1	69.1	57.3	44.3	85.9	75.9	67.9	55.6	42.7	70.0	70.0	70.0	58.6	44.9
10.0	79.6	69.4	62.2	47.4	36.7	78.1	67.7	60.5	45.3	34.6	76.9	66.4	59.3	43.8	33.1	70.0	69.0	61.8	46.9	36.2
11.0	71.3	61.7	53.0	38.8	29.7	69.5	60.0	51.0	36.8	27.7	68.3	58.7	49.6	35.4	26.3	70.0	61.2	52.4	38.3	29.1
12.0						62.3	53.5	42.9	30.5	22.6	61.1	52.3	41.5	29.2	21.2	63.5	54.8	44.2	31.9	23.9
14.0						51.4	41.5	31.7	21.8	15.5	50.2	40.2	30.4	20.6	14.2	52.1	42.7	32.9	23.0	16.7
16.0						41.6	32.5	24.3	16.2	10.9	41.8	31.2	23.1	14.9	9.6	43.6	33.5	25.4	17.2	11.9
18.0											34.2	24.9	17.9	10.9	5.6	36.3	27.0	20.0	13.0	8.5
20.0											28.3	20.2	14.1	7.5		30.3	22.2	16.1	10.0	5.4
22.0																25.6	18.4	13.0	7.3	3.0
24.0																21.9	15.4	10.6	5.0	
26.0																18.9	13.0	8.5	3.1	
28.0																16.4	11.0	6.5		
30.0																				
32.0																				
34.0																				
36.0																				
38.0																				
40.0																				
42.0																				
44.0																				
46.0																				
危険角度 (°)	-	-	-	-	-	-	-	-	-	-	-	-	-	-	24	-	-	-	25	41
フック種類	120t					120t					120t					83t				
フック質量 (t)	1.90					1.90					1.90					1.00				
巻掛本数	12					12					12					7				

メインブーム (アウトリガ 8.4m)

作業半径 (m)	40.9m ブーム					45.5m ブーム					50.0m ブーム				
	性能区分					性能区分					性能区分				
	A2	B2	C2	D2	E2	A2	B2	C2	D2	E2	A2	B2	C2	D2	E2
3.0															
3.5															
4.0															
4.5															
5.0															
6.0															
7.0	60.0	60.0	60.0	60.0	60.0										
8.0	60.0	60.0	60.0	60.0	51.9	47.0	47.0	47.0	47.0	47.0	35.0	35.0	35.0	35.0	35.0
9.0	60.0	60.0	60.0	54.9	42.2	47.0	47.0	47.0	47.0	40.7	35.0	35.0	35.0	35.0	35.0
10.0	60.0	60.0	60.0	46.1	35.0	47.0	47.0	47.0	44.7	33.9	35.0	35.0	35.0	35.0	33.4
11.0	60.0	60.0	53.8	39.3	29.4	47.0	47.0	47.0	38.2	28.7	35.0	35.0	35.0	35.0	28.4
12.0	60.0	55.9	45.5	33.1	25.0	47.0	47.0	45.8	33.1	24.4	35.0	35.0	35.0	32.7	24.3
14.0	52.1	43.8	34.0	24.2	17.8	47.0	44.1	34.3	24.5	18.0	35.0	35.0	34.9	25.1	18.1
16.0	44.7	34.6	26.4	18.3	13.0	42.9	34.9	26.7	18.5	13.3	35.0	35.0	27.3	19.1	13.7
18.0	37.3	28.0	21.0	14.1	9.6	37.6	28.3	21.3	14.3	9.8	35.0	28.8	21.8	14.9	10.3
20.0	31.2	23.1	17.0	10.9	6.7	31.5	23.4	17.3	11.2	7.1	31.4	23.9	17.8	11.7	7.7
22.0	26.5	19.3	13.9	8.5	4.3	26.8	19.6	14.2	8.8	4.7	27.3	20.1	14.6	9.2	5.3
24.0	22.8	16.3	11.5	6.2		23.0	16.6	11.7	6.6		23.5	17.0	12.1	7.1	
26.0	19.7	13.9	9.4	4.3		20.0	14.1	9.7	4.6		20.4	14.5	10.1	5.2	
28.0	17.2	11.8	7.6			17.4	12.1	8.0	3.1		17.9	12.5	8.4	3.6	
30.0	15.1	10.1	5.9			15.3	10.3	6.3			15.7	10.7	6.8		
32.0	13.3	8.7	4.5			13.5	8.9	4.8			13.9	9.2	5.3		
34.0	11.7	7.2	3.3			11.9	7.5	3.5			12.3	7.9	4.0		
36.0	10.4	5.9				10.5	6.2				10.9	6.6			
38.0	9.2	4.8				9.4	5.0				9.7	5.4			
40.0						8.3	4.0				8.6	4.3			
42.0						7.2	3.1				7.5	3.4			
44.0											6.5				
46.0											5.6				
危険角度 (°)	-	-	22	43	53	-	-	33	48	58	7	20	39	52	61
フック種類	83t					83t					83t				
フック質量 (t)	1.00					1.00					1.00				
巻掛本数	6					4					4				

メインブーム (アウトリガ 7.4 m)

(単位 : ton)

作業半径 (m)	13.6m ブーム						18.15m ブーム						22.7m ブーム						31.8m ブーム					
	性能区分						性能区分						性能区分						性能区分					
	重荷重	A3	B3	C3	D3	E3	A3	B3	C3	D3	E3	A3	B3	C3	D3	E3	A3	B3	C3	D3	E3			
3.0	* 220.0	120.0	120.0	120.0	120.0	120.0																		
3.5	197.5	120.0	120.0	120.0	120.0	120.0	120.0	120.0	120.0	120.0														
4.0	179.0	120.0	120.0	120.0	120.0	120.0	120.0	120.0	120.0	120.0	120.0	120.0	120.0	120.0	120.0									
4.5	163.0	120.0	120.0	120.0	120.0	120.0	120.0	120.0	120.0	120.0	120.0	120.0	120.0	120.0	120.0									
5.0	150.0	120.0	120.0	120.0	120.0	116.7	120.0	120.0	120.0	120.0	115.0	120.0	120.0	120.0	120.0	113.7	70.0	70.0	70.0	70.0	70.0			
6.0	128.5	120.0	119.9	113.9	102.1	90.8	120.0	118.6	112.4	100.4	87.9	120.0	117.6	111.1	99.1	80.9	70.0	70.0	70.0	70.0	70.0			
7.0		111.4	104.3	95.5	76.7	60.1	110.0	103.0	93.8	74.3	57.8	109.0	102.0	92.6	72.5	56.0	70.0	70.0	70.0	70.0	70.0	55.2		
8.0		98.3	90.6	76.2	56.4	43.7	96.9	88.9	74.1	54.3	41.6	95.9	87.7	72.6	52.8	40.1	70.0	70.0	70.0	56.0	43.3			
9.0		87.7	75.9	59.8	43.8	33.5	86.2	73.9	57.9	41.9	31.6	85.2	72.6	56.5	40.5	30.2	70.0	70.0	59.4	43.4	33.1			
10.0		78.8	62.2	48.7	35.2	26.6	77.2	60.4	46.9	33.4	24.8	76.0	59.1	45.6	32.1	23.5	70.0	61.8	48.3	34.8	26.1			
11.0		67.8	52.3	40.6	29.0	21.5	66.0	50.5	38.9	27.3	19.8	64.8	49.3	37.7	26.1	18.6	67.3	51.8	40.2	28.6	21.1			
12.0							56.7	43.1	32.9	22.6	16.0	55.5	41.9	31.7	21.4	14.9	57.9	44.3	34.0	23.8	17.2			
14.0							43.5	32.5	24.3	16.0	10.7	42.4	31.4	23.2	14.9	9.6	44.6	33.6	25.4	17.1	11.8			
16.0							34.7	25.5	18.6	11.7	7.2	33.6	24.4	17.5	10.5	5.8	35.6	26.4	19.5	12.6	8.1			
18.0												27.2	19.3	13.4	7.4		29.1	21.2	15.3	9.3	5.3			
20.0												22.5	15.5	10.3			24.3	17.3	12.1	6.9				
22.0																	20.5	14.3	9.6	4.6				
24.0																	17.4	11.8	7.7					
26.0																	14.9	9.9	6.0					
28.0																	12.9	8.2	4.2					
30.0																								
32.0																								
34.0																								
36.0																								
38.0																								
40.0																								
42.0																								
44.0																								
46.0																								
危険角度 (°)	-	-	-	-	-	-	-	-	-	-	-	-	-	-	14	37	-	-	-	36	47			
フック種類	220t	120t					120t					120t					83t							
フック質量 (t)	2.52	1.90					1.90					1.90					1.00							
巻掛本数	10X2	12					12					12					7							

注) *印性能は後方のみ

メインブーム (アウトリガ 7.4 m)

作業半径 (m)	40.9m ブーム					45.5m ブーム					50.0m ブーム				
	性能区分					性能区分					性能区分				
	A3	B3	C3	D3	E3	A3	B3	C3	D3	E3	A3	B3	C3	D3	E3
3.0															
3.5															
4.0															
4.5															
5.0															
6.0															
7.0	60.0	60.0	60.0	60.0	50.6										
8.0	60.0	60.0	60.0	53.3	40.4	47.0	47.0	47.0	47.0	38.8	35.0	35.0	35.0	35.0	35.0
9.0	60.0	60.0	60.0	44.1	33.0	47.0	47.0	47.0	42.7	31.9	35.0	35.0	35.0	35.0	31.3
10.0	60.0	60.0	49.5	36.0	27.3	47.0	47.0	47.0	36.1	26.5	35.0	35.0	35.0	35.0	26.2
11.0	60.0	53.0	41.3	29.7	22.2	47.0	47.0	41.6	30.0	22.3	35.0	35.0	35.0	30.5	22.2
12.0	59.0	45.4	35.1	24.9	18.3	47.0	45.7	35.4	25.2	18.6	35.0	35.0	35.0	25.8	18.8
14.0	45.6	34.6	26.4	18.1	12.8	45.9	34.9	26.6	18.4	13.1	35.0	35.0	27.2	18.9	13.6
16.0	36.5	27.3	20.4	13.5	9.1	36.8	27.6	20.7	13.8	9.4	35.0	28.1	21.2	14.3	9.9
18.0	30.0	22.1	16.2	10.2	6.4	30.3	22.4	16.4	10.5	6.7	30.8	22.8	16.9	11.0	7.1
20.0	25.1	18.2	13.0	7.8		25.4	18.4	13.2	8.0		25.8	18.9	13.7	8.5	
22.0	21.3	15.1	10.5	5.8		21.5	15.4	10.7	6.1		22.0	15.8	11.1	6.5	
24.0	18.2	12.7	8.5	3.8		18.5	12.9	8.7	4.1		18.9	13.3	9.1	4.7	
26.0	15.7	10.6	6.8			15.9	10.9	7.1			16.3	11.3	7.5		
28.0	13.6	9.0	5.3			13.8	9.2	5.7			14.2	9.6	6.1		
30.0	11.9	7.6	3.8			12.1	7.8	4.2			12.4	8.1	4.7		
32.0	10.4	6.4				10.6	6.6				10.9	6.9	3.3		
34.0	9.1	5.1				9.2	5.4				9.6	5.8			
36.0	7.9	4.0				8.1	4.2				8.4	4.7			
38.0	7.0					7.1	3.2				7.4	3.6			
40.0						6.2					6.5				
42.0						5.4					5.7				
44.0											4.7				
46.0											3.9				
危険角度 (°)	-	-	33	48	59	-	22	40	53	63	9	31	45	58	66
フック種類	83t					83t					83t				
フック質量 (t)	1.00					1.00					1.00				
巻掛本数	6					4					4				

メインブーム (アウトリガ 6.4m)

(単位 : ton)

作業半径 (m)	13.6m ブーム					18.15m ブーム					22.7m ブーム					31.8m ブーム				
	性能区分					性能区分					性能区分					性能区分				
	A4	B4	C4	D4	E4	A4	B4	C4	D4	E4	A4	B4	C4	D4	E4	A4	B4	C4	D4	E4
3.0	120.0	120.0	120.0	120.0	120.0															
3.5	120.0	120.0	120.0	120.0	120.0	120.0	120.0	120.0	120.0	120.0										
4.0	120.0	120.0	120.0	120.0	120.0	120.0	120.0	120.0	120.0	120.0	120.0	120.0	120.0	120.0						
4.5	120.0	120.0	120.0	120.0	120.0	120.0	120.0	120.0	120.0	120.0	120.0	120.0	120.0	120.0	105.2					
5.0	120.0	120.0	120.0	120.0	104.6	120.0	120.0	120.0	120.0	96.9	120.0	120.0	120.0	110.7	84.4	70.0	70.0	70.0	70.0	70.0
6.0	120.0	119.9	110.4	81.8	63.5	120.0	118.6	107.9	79.4	61.1	120.0	117.6	106.1	77.6	58.5	70.0	70.0	70.0	70.0	54.3
7.0	111.4	99.6	78.5	57.5	44.0	110.0	97.5	76.5	55.5	42.0	109.0	96.0	74.9	53.9	40.4	70.0	70.0	70.0	55.7	41.4
8.0	98.3	76.6	60.0	43.4	32.7	96.9	74.8	58.1	41.5	30.8	95.6	73.4	56.8	40.1	29.4	70.0	70.0	59.6	43.0	32.3
9.0	80.0	61.6	47.9	34.1	25.2	78.3	59.9	46.1	32.3	23.5	77.0	58.6	44.9	31.1	22.2	70.0	61.3	47.5	33.7	24.9
10.0	66.7	51.1	39.3	27.6	20.0	65.1	49.4	37.6	25.9	18.4	63.9	48.2	36.5	24.7	17.2	66.3	50.7	38.9	27.2	19.6
11.0	56.9	43.2	33.0	22.7	16.2	55.2	41.6	31.4	21.1	14.5	54.1	40.5	30.2	20.0	13.4	56.4	42.8	32.5	22.3	15.7
12.0						47.7	35.6	26.5	17.4	11.6	46.6	34.5	25.4	16.3	10.5	48.8	36.7	27.6	18.5	12.7
14.0						36.8	26.9	19.5	12.1	7.4	35.7	25.8	18.4	11.0	6.0	37.8	27.9	20.5	13.1	8.4
16.0						29.3	21.0	14.8	8.5		28.2	19.9	13.7	7.4		30.2	21.9	15.6	9.4	5.1
18.0											22.8	15.6	10.2			24.7	17.5	12.1	6.7	
20.0											18.8	12.4	7.7			20.5	14.2	9.4	4.1	
22.0																17.2	11.5	7.3		
24.0																14.5	9.4	5.3		
26.0																12.4	7.7	3.5		
28.0																10.6	6.2			
30.0																				
32.0																				
34.0																				
36.0																				
38.0																				
40.0																				
42.0																				
44.0																				
46.0																				
危険角度 (°)	-	-	-	-	-	-	-	-	-	13	-	-	-	30	46	-	-	22	44	55
フック種類	120t					120t					120t					83t				
フック質量 (t)	1.90					1.90					1.90					1.00				
巻掛本数	12					12					12					7				

メインブーム (アウトリガ 6.4m)

作業半径 (m)	40.9m ブーム					45.5m ブーム					50.0m ブーム				
	性能区分					性能区分					性能区分				
	A4	B4	C4	D4	E4	A4	B4	C4	D4	E4	A4	B4	C4	D4	E4
3.0															
3.5															
4.0															
4.5															
5.0															
6.0															
7.0	60.0	60.0	60.0	51.5	38.4										
8.0	60.0	60.0	59.4	41.9	30.7	47.0	47.0	47.0	40.4	29.5	35.0	35.0	35.0	35.0	29.0
9.0	60.0	60.0	48.7	34.7	24.9	47.0	47.0	47.0	33.6	24.1	35.0	35.0	35.0	33.1	23.8
10.0	60.0	51.8	40.0	28.3	20.5	47.0	47.0	40.3	28.4	19.9	35.0	35.0	35.0	28.1	19.8
11.0	57.5	43.9	33.6	23.4	16.8	47.0	44.1	33.9	23.7	16.5	35.0	35.0	34.5	24.0	16.6
12.0	49.8	37.7	28.6	19.6	13.7	47.0	38.0	28.9	19.8	13.7	35.0	35.0	29.5	20.4	13.9
14.0	38.7	28.9	21.5	14.1	9.3	39.0	29.1	21.7	14.3	9.4	35.0	29.6	22.3	14.9	9.7
16.0	31.1	22.8	16.6	10.3		31.4	23.1	16.8	10.6		31.8	23.5	17.3	11.0	
18.0	25.6	18.4	13.0	7.6		25.8	18.6	13.2	7.8		26.3	19.1	13.7	8.3	
20.0	21.3	15.0	10.2	5.4		21.6	15.2	10.5	5.7		22.0	15.7	10.9	6.2	
22.0	18.0	12.4	8.1			18.2	12.6	8.3			18.7	13.0	8.7		
24.0	15.3	10.2	6.4			15.6	10.4	6.6			16.0	10.8	7.0		
26.0	13.1	8.5	4.7			13.4	8.7	5.0			13.7	9.1	5.5		
28.0	11.3	7.0	3.1			11.5	7.2	3.4			11.9	7.6	3.9		
30.0	9.7	5.7				9.9	6.0				10.3	6.3			
32.0	8.4	4.3				8.6	4.6				8.9	5.1			
34.0	7.3	3.1				7.4	3.4				7.8	3.9			
36.0	6.3					6.4					6.7				
38.0	5.2					5.4					5.8				
40.0						4.4					4.8				
42.0						3.6					3.9				
44.0											3.0				
46.0															
危険角度 (°)	-	23	41	55	65	-	33	47	59	68	15	39	50	63	70
フック種類	83t					83t					83t				
フック質量 (t)	1.00					1.00					1.00				
巻掛本数	6					4					4				



メインブーム【通常伸縮】定格総荷重表

メインブーム (アウトリガ 5.4m)

(単位 : ton)

作業半径 (m)	13.6m ブーム				18.15m ブーム				22.7m ブーム				31.8m ブーム								
	性能区分				性能区分				性能区分				性能区分								
	-	B5	C5	D5	E5	-	B5	C5	D5	E5	-	B5	C5	D5	E5	-	B5	C5	D5	E5	
3.0		120.0	120.0	120.0	120.0																
3.5		120.0	120.0	120.0	120.0		120.0	120.0	120.0	120.0											
4.0		120.0	120.0	120.0	120.0		120.0	120.0	120.0	104.6		120.0	120.0	118.9	89.4						
4.5		120.0	120.0	109.6	84.6		120.0	120.0	106.9	81.9		120.0	120.0	95.8	71.3						
5.0		120.0	114.2	83.6	64.1		120.0	111.8	81.3	61.8		120.0	110.1	79.4	58.4		70.0	70.0	70.0	53.2	
6.0		97.8	76.6	55.3	41.7		95.9	74.6	53.4	39.7		94.5	73.2	51.9	38.3		70.0	70.0	53.9	39.2	
7.0		72.8	56.5	40.1	29.7		71.1	54.8	38.4	28.0		69.8	53.5	37.2	26.7		70.0	56.2	39.8	29.4	
8.0		57.2	44.0	30.7	22.2		55.6	42.4	29.1	20.6		54.5	41.2	28.0	19.5		56.9	43.6	30.4	21.9	
9.0		46.6	35.4	24.3	17.1		45.1	33.9	22.8	15.6		44.0	32.8	21.7	14.6		46.3	35.1	24.0	16.8	
10.0		38.9	29.3	19.6	13.5		37.4	27.8	18.2	12.0		36.4	26.8	17.1	11.0		38.5	28.9	19.3	13.1	
11.0		33.1	24.6	16.1	10.7		31.6	23.2	14.7	9.3		30.6	22.2	13.7	8.3		32.7	24.2	15.8	10.3	
12.0							27.1	19.5	12.0	7.1		26.1	18.5	11.0	6.2		28.1	20.5	13.0	8.1	
14.0							20.4	14.2	8.0			19.5	13.2	7.0			21.3	15.1	8.9		
16.0							15.8	10.5				14.8	9.6				16.6	11.3	6.1		
18.0												11.5	6.9				13.1	8.5	3.6		
20.0												8.9					10.5	6.4			
22.0																	8.4	4.6			
24.0																	6.7				
26.0																	5.3				
28.0																	3.8				
30.0																					
32.0																					
34.0																					
36.0																					
38.0																					
40.0																					
42.0																					
44.0																					
46.0																					
危険角度 (°)		-	-	-	-		-	-	-	34		-	12	41	53		5	35	51	62	
フック種類		120t					120t					120t					83t				
フック質量 (t)		1.90					1.90					1.90					1.00				
巻掛本数		12					12					12					7				

メインブーム (アウトリガ 5.4m)

作業半径 (m)	40.9m ブーム				45.5m ブーム				50.0m ブーム						
	性能区分				性能区分				性能区分						
	-	B5	C5	D5	E5	-	B5	C5	D5	E5	-	B5	C5	D5	E5
3.0															
3.5															
4.0															
4.5															
5.0															
6.0															
7.0		60.0	56.9	39.3	28.0										
8.0		58.0	44.7	31.5	22.3		47.0	45.0	30.9	21.5		35.0	35.0	30.3	21.2
9.0		47.3	36.1	25.0	17.8		47.0	36.4	25.3	17.3		35.0	35.0	25.4	17.2
10.0		39.5	29.9	20.3	14.1		39.8	30.2	20.5	14.0		35.0	30.7	21.1	14.0
11.0		33.6	25.2	16.7	11.3		33.9	25.4	16.9	11.3		34.4	25.9	17.5	11.5
12.0		29.0	21.4	13.9	9.0		29.2	21.7	14.1	9.1		29.7	22.2	14.6	9.3
14.0		22.2	16.0	9.8			22.4	16.2	10.0			22.9	16.7	10.4	
16.0		17.4	12.2	6.9			17.7	12.4	7.1			18.1	12.8	7.5	
18.0		13.9	9.3				14.2	9.6				14.6	10.0		
20.0		11.2	7.2				11.5	7.4				11.9	7.8		
22.0		9.1	5.5				9.3	5.7				9.7	6.1		
24.0		7.4	3.9				7.6	4.2				8.0	4.7		
26.0		6.0					6.2					6.5			
28.0		4.8					5.0					5.3			
30.0		3.4					3.7					4.2			
32.0															
34.0															
36.0															
38.0															
40.0															
42.0															
44.0															
46.0															
危険角度 (°)		35	48	62	70		42	52	65	72		46	57	68	74
フック種類		83t					83t					83t			
フック質量 (t)		1.00					1.00					1.00			
巻掛本数		6					4					4			



メインブーム【特殊伸縮】定格総荷重表

メインブーム【特殊伸縮】(アウトリガ 9.4m)

(単位 : ton)

作業半径 (m)	13.6m ブーム					18.15m ブーム					22.7m ブーム					31.8m ブーム				
	性能区分					性能区分					性能区分					性能区分				
	TA1	TB1	TC1	TD1	TE1	TA1	TB1	TC1	TD1	TE1	TA1	TB1	TC1	TD1	TE1	TA1	TB1	TC1	TD1	TE1
3.0	120.0	120.0	120.0	120.0	120.0															
3.5	120.0	120.0	120.0	120.0	120.0	70.0	70.0	70.0	70.0	70.0										
4.0	120.0	120.0	120.0	120.0	120.0	70.0	70.0	70.0	70.0	70.0	70.0	70.0	70.0	70.0						
4.5	120.0	120.0	120.0	120.0	120.0	70.0	70.0	70.0	70.0	70.0	70.0	70.0	70.0	70.0						
5.0	120.0	120.0	120.0	120.0	116.7	70.0	70.0	70.0	70.0	70.0	70.0	70.0	70.0	70.0						
6.0	120.0	119.9	113.9	102.1	94.6	70.0	70.0	70.0	70.0	70.0	70.0	70.0	70.0	70.0	60.0	60.0	60.0	60.0	60.0	60.0
7.0	112.2	104.3	95.5	85.2	78.8	70.0	70.0	70.0	70.0	70.0	70.0	70.0	70.0	70.0	60.0	60.0	60.0	60.0	60.0	60.0
8.0	99.1	90.6	81.6	72.6	67.0	70.0	70.0	70.0	70.0	69.8	70.0	70.0	70.0	69.5	60.0	60.0	60.0	60.0	60.0	60.0
9.0	88.4	78.8	70.8	62.8	57.1	70.0	70.0	70.0	65.4	60.4	70.0	70.0	70.0	65.3	60.3	60.0	60.0	60.0	60.0	60.0
10.0	79.6	69.4	62.2	55.0	45.6	70.0	70.0	64.6	57.4	48.3	70.0	70.0	64.6	57.4	48.6	58.9	58.9	58.9	58.2	49.5
11.0	71.3	61.7	55.2	46.3	37.3	70.0	63.9	57.4	49.5	39.0	68.0	64.1	57.5	49.0	40.2	53.9	53.9	53.9	49.9	41.0
12.0						65.4	57.4	51.5	41.3	32.3	63.1	57.6	51.6	41.6	33.5	49.7	49.7	49.7	42.4	34.3
14.0						54.0	47.2	41.2	30.2	23.2	55.0	47.5	40.9	31.3	24.2	42.9	42.9	41.6	32.1	25.0
16.0						44.2	39.6	32.2	23.2	17.3	46.5	39.9	32.5	24.1	18.3	37.6	37.6	33.1	24.8	19.0
18.0											39.9	33.3	26.5	19.1	14.1	33.3	33.3	27.1	19.7	14.8
20.0											34.7	28.0	22.0	15.4	11.1	29.8	28.5	22.6	16.0	11.7
22.0																26.9	24.4	19.0	13.1	9.3
24.0																24.5	21.1	16.1	10.9	7.5
26.0																22.4	18.4	13.8	9.0	5.7
28.0																20.6	16.1	11.9	7.6	4.2
30.0																				
32.0																				
34.0																				
36.0																				
38.0																				
40.0																				
42.0																				
44.0																				
46.0																				
危険角度 (°)	-	-	-	-	-	-	-	-	-	-	-	-	-	-	-	-	-	-	-	-
フック種類	120t					83t					83t					83t				
フック質量 (t)	1.90					1.00					1.00					1.00				
巻掛本数	12					7					7					6				

メインブーム【特殊伸縮】(アウトリガ 9.4m)

作業半径 (m)	40.9m ブーム				
	性能区分				
	TA1	TB1	TC1	TD1	TE1
3.0					
3.5					
4.0					
4.5					
5.0					
6.0					
7.0					
8.0	35.0	35.0	35.0	35.0	35.0
9.0	35.0	35.0	35.0	35.0	35.0
10.0	35.0	35.0	35.0	35.0	35.0
11.0	35.0	35.0	35.0	35.0	35.0
12.0	35.0	35.0	35.0	35.0	35.0
14.0	35.0	35.0	35.0	32.6	25.6
16.0	31.9	31.9	31.9	25.3	19.5
18.0	28.1	28.1	27.5	20.2	15.2
20.0	24.9	24.9	23.0	16.4	12.1
22.0	22.4	22.4	19.4	13.5	9.7
24.0	20.2	20.2	16.5	11.2	7.8
26.0	18.3	18.3	14.1	9.4	6.1
28.0	16.7	16.4	12.2	7.8	4.6
30.0	15.3	14.5	10.6	6.5	3.3
32.0	14.0	12.9	9.2	5.1	
34.0	12.9	11.4	8.0	4.0	
36.0	11.9	10.2	7.0	3.0	
38.0	11.0	9.2	5.9		
40.0					
42.0					
44.0					
46.0					
危険角度 (°)	-	-	-	12	35
フック種類	83t				
フック質量 (t)	1.00				
巻掛本数	4				

メインブーム【特殊伸縮】(アウトリガ 8.4m)

(単位: ton)

作業半径 (m)	13.6m ブーム					18.15m ブーム					22.7m ブーム					31.8m ブーム				
	性能区分					性能区分					性能区分					性能区分				
	TA2	TB2	TC2	TD2	TE2	TA2	TB2	TC2	TD2	TE2	TA2	TB2	TC2	TD2	TE2	TA2	TB2	TC2	TD2	TE2
3.0	120.0	120.0	120.0	120.0	120.0															
3.5	120.0	120.0	120.0	120.0	120.0	70.0	70.0	70.0	70.0	70.0										
4.0	120.0	120.0	120.0	120.0	120.0	70.0	70.0	70.0	70.0	70.0	70.0	70.0	70.0	70.0						
4.5	120.0	120.0	120.0	120.0	120.0	70.0	70.0	70.0	70.0	70.0	70.0	70.0	70.0	70.0						
5.0	120.0	120.0	120.0	120.0	116.7	70.0	70.0	70.0	70.0	70.0	70.0	70.0	70.0	70.0						
6.0	120.0	119.9	113.9	102.1	94.6	70.0	70.0	70.0	70.0	70.0	70.0	70.0	70.0	70.0	60.0	60.0	60.0	60.0	60.0	60.0
7.0	112.2	104.3	95.5	85.2	78.8	70.0	70.0	70.0	70.0	70.0	70.0	70.0	70.0	70.0	60.0	60.0	60.0	60.0	60.0	60.0
8.0	99.1	90.6	81.6	72.6	61.8	70.0	70.0	70.0	70.0	64.1	70.0	70.0	70.0	65.6	60.0	60.0	60.0	60.0	60.0	60.0
9.0	88.4	78.8	70.8	59.5	46.6	70.0	70.0	70.0	61.5	48.6	70.0	70.0	70.0	62.9	49.9	60.0	60.0	60.0	60.0	50.8
10.0	79.6	69.4	62.2	47.4	36.7	70.0	70.0	64.6	49.1	38.4	70.0	70.0	64.6	50.4	39.7	58.9	58.9	58.9	51.3	40.6
11.0	71.3	61.7	53.0	38.8	29.7	70.0	63.9	54.6	40.4	31.3	68.0	64.1	55.7	41.6	32.4	53.9	53.9	53.9	42.4	33.3
12.0						65.4	57.4	46.3	33.9	25.9	63.1	57.6	47.4	35.0	27.0	49.7	49.7	48.2	35.8	27.9
14.0						54.0	44.5	34.8	24.9	18.6	54.3	45.6	35.8	25.9	19.6	42.9	42.9	36.5	26.7	20.3
16.0						44.2	35.3	27.2	19.0	13.8	45.9	36.3	28.1	19.9	14.7	37.6	36.9	28.8	20.6	15.3
18.0											39.0	29.7	22.7	15.7	11.2	33.3	30.3	23.3	16.3	11.8
20.0											32.9	24.8	18.7	12.6	8.7	29.8	25.3	19.2	13.1	9.2
22.0																26.9	21.5	16.1	10.7	7.2
24.0																24.5	18.4	13.6	8.7	5.3
26.0																21.9	16.0	11.6	7.1	3.7
28.0																19.3	14.0	9.9	5.6	
30.0																				
32.0																				
34.0																				
36.0																				
38.0																				
40.0																				
42.0																				
44.0																				
46.0																				
危険角度 (°)	-	-	-	-	-	-	-	-	-	-	-	-	-	-	-	-	-	-	-	19
フック種類	120t					83t					83t					83t				
フック質量 (t)	1.90					1.00					1.00					1.00				
巻掛本数	12					7					7					6				

メインブーム【特殊伸縮】(アウトリガ 8.4m)

作業半径 (m)	40.9m ブーム				
	TA2	TB2	TC2	TD2	TE2
3.0					
3.5					
4.0					
4.5					
5.0					
6.0					
7.0					
8.0	35.0	35.0	35.0	35.0	35.0
9.0	35.0	35.0	35.0	35.0	35.0
10.0	35.0	35.0	35.0	35.0	35.0
11.0	35.0	35.0	35.0	35.0	33.8
12.0	35.0	35.0	35.0	35.0	28.5
14.0	35.0	35.0	35.0	27.2	20.9
16.0	31.9	31.9	29.3	21.1	15.8
18.0	28.1	28.1	23.8	16.8	12.3
20.0	24.9	24.9	19.6	13.5	9.6
22.0	22.4	21.9	16.5	11.1	7.6
24.0	20.2	18.8	13.9	9.1	5.7
26.0	18.3	16.3	11.9	7.5	4.1
28.0	16.7	14.2	10.2	5.9	
30.0	15.3	12.5	8.7	4.6	
32.0	14.0	11.0	7.5	3.4	
34.0	12.9	9.7	6.3		
36.0	11.9	8.6	5.2		
38.0	11.0	7.6	4.3		
40.0					
42.0					
44.0					
46.0					
危険角度 (°)	-	-	-	28	42
フック種類	83t				
フック質量 (t)	1.00				
巻掛本数	4				

メインブーム【特殊伸縮】(アウトリガ7.4m)

(単位: ton)

作業半径 (m)	13.6m ブーム					18.15m ブーム					22.7m ブーム					31.8m ブーム				
	性能区分					性能区分					性能区分					性能区分				
	TA3	TB3	TC3	TD3	TE3	TA3	TB3	TC3	TD3	TE3	TA3	TB3	TC3	TD3	TE3	TA3	TB3	TC3	TD3	TE3
3.0	120.0	120.0	120.0	120.0	120.0															
3.5	120.0	120.0	120.0	120.0	120.0	70.0	70.0	70.0	70.0	70.0										
4.0	120.0	120.0	120.0	120.0	120.0	70.0	70.0	70.0	70.0	70.0	70.0	70.0	70.0	70.0						
4.5	120.0	120.0	120.0	120.0	120.0	70.0	70.0	70.0	70.0	70.0	70.0	70.0	70.0	70.0						
5.0	120.0	120.0	120.0	120.0	116.7	70.0	70.0	70.0	70.0	70.0	70.0	70.0	70.0	70.0						
6.0	120.0	119.9	113.9	102.1	90.8	70.0	70.0	70.0	70.0	70.0	70.0	70.0	70.0	70.0	60.0	60.0	60.0	60.0	60.0	60.0
7.0	111.4	104.3	95.5	76.7	60.1	70.0	70.0	70.0	70.0	62.3	70.0	70.0	70.0	63.8	60.0	60.0	60.0	60.0	60.0	60.0
8.0	98.3	90.6	76.2	56.4	43.7	70.0	70.0	70.0	58.3	45.6	70.0	70.0	70.0	59.6	46.9	60.0	60.0	60.0	60.0	47.8
9.0	87.7	75.9	59.8	43.8	33.5	70.0	70.0	61.5	45.5	35.2	70.0	70.0	62.7	46.6	36.3	60.0	60.0	60.0	47.5	37.2
10.0	78.8	62.2	48.7	35.2	26.6	70.0	63.6	50.2	36.7	28.1	70.0	64.8	51.3	37.8	29.1	58.9	58.9	52.1	38.6	29.9
11.0	67.8	52.3	40.6	29.0	21.5	69.1	53.6	42.0	30.4	22.9	68.0	54.7	43.0	31.4	23.9	53.9	53.9	43.8	32.2	24.7
12.0						59.6	46.0	35.8	25.6	19.0	60.6	47.0	36.8	26.5	20.0	49.7	47.7	37.5	27.3	20.7
14.0						46.2	35.2	27.0	18.8	13.5	47.1	36.2	27.9	19.7	14.4	42.9	36.8	28.6	20.3	15.0
16.0						37.2	28.0	21.1	14.2	9.8	38.1	28.9	22.0	15.1	10.6	37.6	29.5	22.6	15.7	11.2
18.0											31.5	23.6	17.7	11.7	7.9	32.1	24.2	18.2	12.3	8.5
20.0											26.6	19.7	14.5	9.3	5.9	27.1	20.2	15.0	9.8	6.4
22.0																23.3	17.1	12.4	7.8	4.8
24.0																20.2	14.6	10.4	6.2	3.1
26.0																17.7	12.6	8.8	4.9	
28.0																15.6	10.9	7.4	3.6	
30.0																				
32.0																				
34.0																				
36.0																				
38.0																				
40.0																				
42.0																				
44.0																				
46.0																				
危険角度 (°)	-	-	-	-	-	-	-	-	-	-	-	-	-	-	-	-	-	-	-	32
フック種類	120t					83t					83t					83t				
フック質量 (t)	1.90					1.00					1.00					1.00				
巻掛本数	12					7					7					6				

メインブーム【特殊伸縮】(アウトリガ7.4m)

作業半径 (m)	40.9m ブーム				
	性能区分				
	TA3	TB3	TC3	TD3	TE3
3.0					
3.5					
4.0					
4.5					
5.0					
6.0					
7.0					
8.0	35.0	35.0	35.0	35.0	35.0
9.0	35.0	35.0	35.0	35.0	35.0
10.0	35.0	35.0	35.0	35.0	30.5
11.0	35.0	35.0	35.0	32.7	25.2
12.0	35.0	35.0	35.0	27.8	21.2
14.0	35.0	35.0	29.0	20.8	15.5
16.0	31.9	29.9	23.0	16.1	11.6
18.0	28.1	24.6	18.6	12.7	8.9
20.0	24.9	20.6	15.4	10.1	6.8
22.0	22.4	17.4	12.8	8.2	5.2
24.0	20.2	14.9	10.7	6.6	3.5
26.0	17.9	12.9	9.1	5.3	
28.0	15.8	11.2	7.7	3.9	
30.0	14.0	9.7	6.5		
32.0	12.5	8.5	5.5		
34.0	11.1	7.4	4.5		
36.0	10.0	6.5	3.5		
38.0	9.0	5.7			
40.0					
42.0					
44.0					
46.0					
危険角度 (°)	-	-	-	37	48
フック種類	83t				
フック質量 (t)	1.00				
巻掛本数	4				

メインブーム【特殊伸縮】(アウトリガ 6.4m)

(単位: ton)

作業半径 (m)	13.6m ブーム					18.15m ブーム					22.7m ブーム					31.8m ブーム				
	性能区分					性能区分					性能区分					性能区分				
	TA4	TB4	TC4	TD4	TE4	TA4	TB4	TC4	TD4	TE4	TA4	TB4	TC4	TD4	TE4	TA4	TB4	TC4	TD4	TE4
3.0	120.0	120.0	120.0	120.0	120.0															
3.5	120.0	120.0	120.0	120.0	120.0	70.0	70.0	70.0	70.0	70.0										
4.0	120.0	120.0	120.0	120.0	120.0	70.0	70.0	70.0	70.0	70.0	70.0	70.0	70.0	70.0						
4.5	120.0	120.0	120.0	120.0	120.0	70.0	70.0	70.0	70.0	70.0	70.0	70.0	70.0	70.0						
5.0	120.0	120.0	120.0	120.0	104.6	70.0	70.0	70.0	70.0	70.0	70.0	70.0	70.0	70.0						
6.0	120.0	119.9	110.4	81.8	63.5	70.0	70.0	70.0	70.0	65.8	70.0	70.0	70.0	70.0	67.3	60.0	60.0	60.0	60.0	60.0
7.0	111.4	99.6	78.5	57.5	44.0	70.0	70.0	70.0	59.4	45.9	70.0	70.0	70.0	60.7	47.2	60.0	60.0	60.0	60.0	47.2
8.0	98.3	76.6	60.0	43.4	32.7	70.0	70.0	61.7	45.0	34.4	70.0	70.0	62.8	46.2	35.5	60.0	60.0	60.0	47.1	36.4
9.0	80.0	61.6	47.9	34.1	25.2	70.0	63.1	49.4	35.6	26.8	70.0	64.2	50.4	36.7	27.8	60.0	60.0	51.2	37.5	28.6
10.0	66.7	51.1	39.3	27.6	20.0	68.1	52.4	40.7	29.0	21.4	69.1	53.5	41.7	30.0	22.4	58.9	54.2	42.5	30.7	23.2
11.0	56.9	43.2	33.0	22.7	16.2	58.1	44.5	34.3	24.0	17.4	59.1	45.5	35.2	25.0	18.4	53.9	46.2	35.9	25.7	19.1
12.0						50.4	38.3	29.3	20.2	14.4	51.4	39.3	30.2	21.1	15.3	49.7	40.0	30.9	21.8	16.0
14.0						39.3	29.5	22.1	14.7	10.0	40.2	30.4	23.0	15.6	10.8	40.8	31.0	23.6	16.2	11.4
16.0						31.8	23.5	17.2	11.0	7.0	32.6	24.3	18.0	11.8	7.8	33.1	24.8	18.6	12.3	8.3
18.0											27.0	19.8	14.4	9.0	5.5	27.5	20.3	14.9	9.5	6.1
20.0											22.8	16.5	11.7	7.0	3.5	23.3	16.9	12.2	7.4	4.2
22.0																19.9	14.3	10.0	5.8	
24.0																17.2	12.1	8.3	4.2	
26.0																15.0	10.4	6.9		
28.0																13.2	8.9	5.7		
30.0																				
32.0																				
34.0																				
36.0																				
38.0																				
40.0																				
42.0																				
44.0																				
46.0																				
危険角度 (°)	-	-	-	-	-	-	-	-	-	-	-	-	-	-	-	-	-	-	25	42
フック種類	120t					83t					83t					83t				
フック質量 (t)	1.90					1.00					1.00					1.00				
巻掛本数	12					7					7					6				

メインブーム【特殊伸縮】(アウトリガ 6.4m)

作業半径 (m)	40.9m ブーム				
	TA4	TB4	TC4	TD4	TE4
3.0					
3.5					
4.0					
4.5					
5.0					
6.0					
7.0					
8.0	35.0	35.0	35.0	35.0	35.0
9.0	35.0	35.0	35.0	35.0	29.2
10.0	35.0	35.0	35.0	31.3	23.7
11.0	35.0	35.0	35.0	26.2	19.6
12.0	35.0	35.0	31.4	22.3	16.5
14.0	35.0	31.4	24.0	16.6	11.9
16.0	31.9	25.2	19.0	12.8	8.8
18.0	27.9	20.7	15.3	9.9	6.5
20.0	23.6	17.3	12.5	7.8	4.7
22.0	20.3	14.6	10.3	6.1	
24.0	17.5	12.4	8.6	4.7	
26.0	15.3	10.6	7.1		
28.0	13.4	9.1	5.9		
30.0	11.8	7.9	4.9		
32.0	10.5	6.8	3.7		
34.0	9.3	5.8			
36.0	8.3	5.0			
38.0	7.4	4.2			
40.0					
42.0					
44.0					
46.0					
危険角度 (°)	-	-	25	49	55
フック種類	83t				
フック質量 (t)	1.00				
巻掛本数	4				



メインブーム【特殊伸縮】定格総荷重表

メインブーム【特殊伸縮】(アウトリガ 5.4m)

(単位 : ton)

作業半径 (m)	13.6m ブーム				18.15m ブーム				22.7m ブーム				31.8m ブーム							
	性能区分				性能区分				性能区分				性能区分							
	-	TB5	TC5	TD5	TE5	-	TB5	TC5	TD5	TE5	-	TB5	TC5	TD5	TE5	-	TB5	TC5	TD5	TE5
3.0		120.0	120.0	120.0	120.0															
3.5		120.0	120.0	120.0	120.0															
4.0		120.0	120.0	120.0	120.0		70.0	70.0	70.0	70.0										
4.5		120.0	120.0	109.6	84.6		70.0	70.0	70.0	70.0		70.0	70.0	70.0	70.0					
5.0		120.0	114.2	83.6	64.1		70.0	70.0	70.0	66.3		70.0	70.0	70.0	67.8					
6.0		97.8	76.6	55.3	41.7		70.0	70.0	57.1	43.5		70.0	70.0	58.3	44.7		60.0	60.0	59.2	44.9
7.0		72.8	56.5	40.1	29.7		70.0	58.0	41.7	31.3		70.0	59.1	42.8	32.3		60.0	59.9	43.6	33.1
8.0		57.2	44.0	30.7	22.2		58.6	45.4	32.1	23.7		59.6	46.4	33.1	24.6		60.0	47.1	33.8	25.4
9.0		46.6	35.4	24.3	17.1		47.9	36.8	25.6	18.5		48.8	37.7	26.5	19.4		49.5	38.3	27.2	20.1
10.0		38.9	29.3	19.6	13.5		40.1	30.5	20.9	14.7		41.0	31.4	21.7	15.6		41.6	32.0	22.4	16.2
11.0		33.1	24.6	16.1	10.7		34.2	25.7	17.3	11.9		35.0	26.6	18.1	12.7		35.6	27.2	18.7	13.3
12.0							29.5	22.0	14.5	9.6		30.4	22.8	15.3	10.4		31.0	23.4	15.9	11.0
14.0							22.7	16.5	10.3	6.3		23.5	17.3	11.1	7.1		24.1	17.9	11.6	7.7
16.0							18.0	12.8	7.5	4.0		18.7	13.5	8.2	4.8		19.3	14.0	8.7	5.3
18.0												15.2	10.7	6.1			15.7	11.1	6.5	3.5
20.0												12.6	8.5	4.5			13.0	8.9	4.9	
22.0																	10.9	7.2	3.5	
24.0																	9.1	5.8		
26.0																	7.7	4.7		
28.0																	6.5	3.7		
30.0																				
32.0																				
34.0																				
36.0																				
38.0																				
40.0																				
42.0																				
44.0																				
46.0																				
危険角度 (°)		-	-	-	-		-	-	-	-		-	-	-	28		-	-	38	50
フック種類		120t					83t					83t					83t			
フック質量 (t)		1.90					1.00					1.00					1.00			
巻掛本数		12					7					7					6			

メインブーム【特殊伸縮】(アウトリガ 5.4m)

作業半径 (m)	40.9m ブーム				
	性能区分				
	-	TB5	TC5	TD5	TE5
3.0					
3.5					
4.0					
4.5					
5.0					
6.0					
7.0					
8.0		35.0	35.0	34.4	25.9
9.0		35.0	35.0	27.7	20.6
10.0		35.0	32.5	22.9	16.7
11.0		35.0	27.6	19.2	13.8
12.0		31.4	23.8	16.3	11.5
14.0		24.5	18.3	12.0	8.1
16.0		19.6	14.4	9.1	5.7
18.0		16.1	11.5	6.9	
20.0		13.3	9.3	5.2	
22.0		11.2	7.5	3.9	
24.0		9.4	6.1		
26.0		8.0	4.9		
28.0		6.7	4.0		
30.0		5.7			
32.0		4.8			
34.0		4.1			
36.0		3.2			
38.0					
40.0					
42.0					
44.0					
46.0					
危険角度 (°)		9	36	51	62
フック種類		83t			
フック質量 (t)		1.00			
巻掛本数		4			

SA 性能

40.9m ブーム +1.5m+10.5mSL

ブーム オフセット 作業半径 (m)	40.9m ブーム 10.5mSL(5°)		40.9m ブーム 10.5mSL(15°)		40.9m ブーム 10.5mSL(30°)		40.9m ブーム 10.5mSL(45°)		40.9m ブーム 10.5mSL(60°)	
	ブーム角 (°)	荷重 (ton)	ブーム角 (°)	荷重 (ton)	ブーム角 (°)	荷重 (ton)	ブーム角 (°)	荷重 (ton)	ブーム角 (°)	荷重 (ton)
9.0	80.6	24.0								
10.0	79.5	24.0	81.4	24.0						
11.0	78.5	24.0	80.4	23.3						
12.0	77.5	24.0	79.4	22.4						
14.0	75.5	24.0	77.2	20.9	79.4	16.6	81.2	13.8		
16.0	73.4	23.9	75.0	19.5	77.1	15.9	78.9	13.4	80.0	11.2
18.0	71.2	22.0	72.7	18.3	74.9	15.2	76.5	13.1	77.5	11.0
20.0	69.0	20.3	70.4	17.2	72.6	14.6	74.2	12.7	74.9	10.9
22.0	66.7	18.9	68.1	16.2	70.2	14.1	71.7	12.4	72.3	10.8
24.0	64.3	17.6	65.7	15.4	67.7	13.6	69.1	12.2	69.7	10.7
26.0	61.8	16.5	63.3	14.6	65.2	13.1	66.5	12.0	66.9	10.7
28.0	59.3	15.5	60.8	13.9	62.6	12.7	63.8	11.8	64.0	10.7
30.0	56.6	13.6	58.2	13.3	59.9	12.4	61.0	11.6		
32.0	53.7	11.7	55.4	12.2	57.1	12.1	58.0	11.5		
34.0	50.7	9.9	52.3	10.4	54.1	10.9	54.9	11.2		
36.0	47.6	8.2	49.1	8.7	50.8	9.2	51.4	9.4		
38.0	44.3	6.7	45.8	7.1	47.3	7.6				
40.0	40.7	5.3	42.2	5.7	43.5	6.0				
42.0	37.0	4.1	38.3	4.4	39.4	4.7				
44.0	32.7	3.0	34.0	3.3	34.6	3.4				
46.0										
危険角度 (°)	22		22		30		45		60	
フック種類	24t		24t		24t		24t		24t	
フック質量 (t)	0.88		0.88		0.88		0.88		0.88	
巻掛本数	2		2		2		2		2	

SA 性能

45.5m ブーム +1.5m+10.5mSL

ブーム オフセット 作業半径 (m)	45.5m ブーム 10.5mSL(5°)		45.5m ブーム 10.5mSL(15°)		45.5m ブーム 10.5mSL(30°)		45.5m ブーム 10.5mSL(45°)		45.5m ブーム 10.5mSL(60°)	
	ブーム角 (°)	荷重 (ton)	ブーム角 (°)	荷重 (ton)	ブーム角 (°)	荷重 (ton)	ブーム角 (°)	荷重 (ton)	ブーム角 (°)	荷重 (ton)
10.0	80.7	24.0								
11.0	79.9	24.0								
12.0	78.9	24.0	80.6	23.2						
14.0	77.2	24.0	78.8	21.6	80.7	16.9				
16.0	75.4	24.0	76.8	20.3	78.7	16.2	80.3	13.6	81.3	11.2
18.0	73.5	23.4	74.8	19.0	76.6	15.6	78.3	13.2	79.2	11.1
20.0	71.5	21.6	72.8	18.0	74.6	15.0	76.1	12.9	76.9	10.9
22.0	69.4	20.2	70.7	17.0	72.5	14.4	74.0	12.6	74.6	10.8
24.0	67.3	18.8	68.6	16.1	70.4	14.0	71.7	12.4	72.4	10.8
26.0	65.2	17.7	66.5	15.4	68.2	13.5	69.5	12.1	69.9	10.7
28.0	62.9	15.8	64.2	14.7	65.9	13.1	67.1	11.9	67.5	10.7
30.0	60.4	13.5	61.9	14.0	63.6	12.7	64.8	11.8	64.9	10.7
32.0	57.8	11.6	59.4	12.1	61.2	12.3	62.3	11.6		
34.0	55.2	9.8	56.7	10.3	58.6	11.0	59.7	11.1		
36.0	52.5	8.1	54.0	8.7	55.7	9.2	56.7	9.5		
38.0	49.7	6.6	51.2	7.1	52.7	7.6	53.6	7.9		
40.0	46.7	5.2	48.2	5.7	49.6	6.1	50.3	6.3		
42.0	43.6	4.0	45.0	4.4	46.3	4.8				
44.0	40.3	2.9	41.6	3.2	42.7	3.5				
46.0					38.9	2.4				
危険角度 (°)	33		33		33		45		60	
フック種類	24t		24t		24t		24t		24t	
フック質量 (t)	0.88		0.88		0.88		0.88		0.88	
巻掛本数	2		2		2		2		2	

SA 性能

50.0m ブーム +1.5m+10.5mSL

ブーム オフセット 作業半径 (m)	50.0m ブーム 10.5mSL(5°)		50.0m ブーム 10.5mSL(15°)		50.0m ブーム 10.5mSL(30°)		50.0m ブーム 10.5mSL(45°)		50.0m ブーム 10.5mSL(60°)	
	ブーム角 (°)	荷重 (ton)	ブーム角 (°)	荷重 (ton)	ブーム角 (°)	荷重 (ton)	ブーム角 (°)	荷重 (ton)	ブーム角 (°)	荷重 (ton)
11.0	80.8	20.0								
12.0	80.1	20.0								
14.0	78.5	20.0	80.0	20.0						
16.0	76.8	20.0	78.4	20.0	80.1	16.5	81.5	13.7		
18.0	75.2	20.0	76.7	19.7	78.3	15.9	79.7	13.4	80.4	11.1
20.0	73.5	20.0	74.9	18.7	76.5	15.3	77.7	13.0	78.4	11.0
22.0	71.8	20.0	73.1	17.7	74.7	14.8	75.8	12.8	76.4	10.9
24.0	69.9	18.4	71.1	16.8	72.7	14.3	73.8	12.5	74.4	10.8
26.0	67.9	16.4	69.2	15.7	70.8	13.9	71.9	12.3	72.2	10.7
28.0	65.8	14.7	67.1	14.2	68.8	13.5	69.8	12.1	70.1	10.7
30.0	63.6	13.3	65.0	12.8	66.6	12.3	67.6	11.9	67.9	10.6
32.0	61.3	11.6	62.8	11.6	64.3	11.2	65.4	11.0		
34.0	59.0	9.7	60.5	10.3	62.0	10.2	63.0	10.1		
36.0	56.6	8.1	58.0	8.6	59.6	9.2	60.5	9.2		
38.0	54.0	6.5	55.5	7.0	57.1	7.7	57.8	8.0		
40.0	51.4	5.2	52.8	5.6	54.4	6.2	55.0	6.4		
42.0	48.8	3.9	50.1	4.4	51.5	4.8	52.0	5.0		
44.0	45.9	2.8	47.3	3.2	48.5	3.6				
46.0					45.4	2.5				
危険角度 (°)	39		40		41		45		60	
フック種類	24t		24t		24t		24t		24t	
フック質量 (t)	0.88		0.88		0.88		0.88		0.88	
巻掛本数	2		2		2		2		2	

SA 性能

40.9m ブーム +1.5m+18.9mSL

ブーム オフセット 作業半径 (m)	40.9m ブーム 18.9mSL(5°)		40.9m ブーム 18.9mSL(15°)		40.9m ブーム 18.9mSL(30°)		40.9m ブーム 18.9mSL(45°)		40.9m ブーム 18.9mSL(60°)	
	ブーム角 (°)	荷重 (ton)	ブーム角 (°)	荷重 (ton)	ブーム角 (°)	荷重 (ton)	ブーム角 (°)	荷重 (ton)	ブーム角 (°)	荷重 (ton)
10.0	81.5	10.0								
11.0	80.6	10.0								
12.0	79.8	10.0								
14.0	78.0	10.0	81.0	10.0						
16.0	76.2	10.0	79.2	10.0						
18.0	74.4	10.0	77.3	10.0	81.1	8.1				
20.0	72.5	10.0	75.5	10.0	79.2	7.7				
22.0	70.7	10.0	73.6	9.7	77.1	7.3	80.2	6.0		
24.0	68.9	10.0	71.5	9.1	75.1	7.0	78.0	5.8	80.1	5.1
26.0	66.9	10.0	69.5	8.6	73.0	6.8	75.8	5.7	77.6	5.1
28.0	64.9	9.7	67.5	8.2	70.8	6.5	73.6	5.5	75.2	5.0
30.0	62.8	9.1	65.4	7.8	68.6	6.3	71.2	5.4	72.7	4.9
32.0	60.7	8.6	63.1	7.4	66.4	6.1	68.8	5.3	70.1	4.9
34.0	58.4	8.1	60.9	7.1	64.0	5.9	66.3	5.2	67.3	4.9
36.0	56.1	7.6	58.6	6.8	61.7	5.7	63.7	5.1	64.5	4.8
38.0	53.7	7.2	56.2	6.5	59.1	5.5	61.0	5.0		
40.0	51.3	6.9	53.7	6.2	56.5	5.4	58.2	4.9		
42.0	48.7	6.5	51.1	5.9	53.9	5.3	55.2	4.9		
44.0	45.9	5.7	48.3	5.7	50.9	5.2	51.9	4.9		
46.0	42.9	4.6	45.4	5.2	47.8	5.1	48.4	4.9		
48.0	39.7	3.7	42.1	4.2	44.4	4.7				
50.0	36.2	2.9	38.5	3.3	40.4	3.7				
52.0	32.3	2.1	34.5	2.4	36.0	2.7				
54.0	28.0	1.4	30.0	1.6						
56.0										
危険角度 (°)	25		25		30		45		60	
フック種類	12t		12t		12t		12t		12t	
フック質量 (t)	0.42		0.42		0.42		0.42		0.42	
巻掛本数	1		1		1		1		1	

SA 性能

45.5m ブーム +1.5m+18.9mSL

ブーム オフセット 作業半径 (m)	45.5m ブーム 18.9mSL(5°)		45.5m ブーム 18.9mSL(15°)		45.5m ブーム 18.9mSL(30°)		45.5m ブーム 18.9mSL(45°)		45.5m ブーム 18.9mSL(60°)	
	ブーム角 (°)	荷重 (ton)	ブーム角 (°)	荷重 (ton)	ブーム角 (°)	荷重 (ton)	ブーム角 (°)	荷重 (ton)	ブーム角 (°)	荷重 (ton)
11.0	81.4	10.0								
12.0	80.6	10.0								
14.0	79.0	10.0								
16.0	77.4	10.0	80.3	10.0						
18.0	75.8	10.0	78.5	10.0						
20.0	74.2	10.0	76.9	10.0	80.3	7.8				
22.0	72.5	10.0	75.2	10.0	78.5	7.5	81.3	6.1		
24.0	70.9	10.0	73.4	9.5	76.6	7.2	79.3	5.9	81.2	5.2
26.0	69.2	10.0	71.6	9.0	74.7	6.9	77.3	5.7	79.1	5.1
28.0	67.4	10.0	69.7	8.6	72.8	6.7	75.2	5.6	76.9	5.0
30.0	65.5	9.8	67.9	8.1	70.9	6.5	73.2	5.5	74.6	5.0
32.0	63.6	9.2	65.9	7.8	68.8	6.2	71.1	5.4	72.4	4.9
34.0	61.7	8.7	63.9	7.4	66.8	6.1	68.9	5.3	70.0	4.9
36.0	59.6	8.2	61.8	7.1	64.7	5.9	66.7	5.2	67.5	4.8
38.0	57.5	7.8	59.8	6.8	62.5	5.7	64.3	5.1	65.0	4.8
40.0	55.4	7.4	57.6	6.6	60.3	5.6	61.9	5.0		
42.0	53.0	6.6	55.4	6.3	57.9	5.4	59.4	4.9		
44.0	50.5	5.5	53.0	6.0	55.4	5.3	56.7	4.9		
46.0	47.9	4.4	50.4	5.1	52.9	5.2	53.9	4.9		
48.0	45.2	3.5	47.5	4.1	50.0	4.7	50.9	4.8		
50.0	42.2	2.6	44.6	3.1	46.9	3.7				
52.0	39.2	1.9	41.5	2.3	43.6	2.8				
54.0	35.0	1.4	38.1	1.5	39.9	1.9				
56.0										
危険角度 (°)	33		33		33		45		60	
フック種類	12t		12t		12t		12t		12t	
フック質量 (t)	0.42		0.42		0.42		0.42		0.42	
巻掛本数	1		1		1		1		1	

SA 性能

50.0m ブーム +1.5m+18.9mSL

ブーム オフセット 作業半径 (m)	50.0m ブーム 18.9mSL(5°)		50.0m ブーム 18.9mSL(15°)		50.0m ブーム 18.9mSL(30°)		50.0m ブーム 18.9mSL(45°)		50.0m ブーム 18.9mSL(60°)	
	ブーム角 (°)	荷重 (ton)	ブーム角 (°)	荷重 (ton)	ブーム角 (°)	荷重 (ton)	ブーム角 (°)	荷重 (ton)	ブーム角 (°)	荷重 (ton)
12.0	81.5	10.0								
14.0	80.0	10.0								
16.0	78.6	10.0	81.2	10.0						
18.0	77.2	10.0	79.7	10.0						
20.0	75.6	10.0	78.2	10.0	81.3	8.0				
22.0	74.2	10.0	76.7	10.0	79.7	7.6				
24.0	72.7	10.0	75.2	9.9	78.0	7.4	80.4	6.0		
26.0	71.1	10.0	73.5	9.4	76.3	7.1	78.6	5.8	80.3	5.1
28.0	69.6	10.0	71.8	8.9	74.6	6.8	76.9	5.7	78.3	5.0
30.0	68.0	10.0	70.1	8.5	72.8	6.6	75.0	5.5	76.3	5.0
32.0	66.3	9.4	68.4	8.1	71.0	6.4	73.1	5.4	74.4	4.9
34.0	64.4	8.5	66.6	7.8	69.2	6.2	71.1	5.3	72.3	4.9
36.0	62.6	7.8	64.8	7.4	67.4	6.0	69.2	5.2	70.1	4.8
38.0	60.6	7.1	62.9	7.2	65.4	5.9	67.2	5.1	67.9	4.8
40.0	58.6	6.5	61.0	6.9	63.4	5.7	65.1	5.1	65.6	4.8
42.0	56.6	5.5	59.0	6.6	61.4	5.6	62.9	5.0		
44.0	54.5	5.0	56.9	6.0	59.3	5.4	60.6	4.9		
46.0	52.2	4.2	54.6	4.9	57.2	5.3	58.3	4.9		
48.0	49.8	3.3	52.1	3.9	54.7	4.7	55.8	4.9		
50.0	47.4	2.5	49.6	3.0	52.1	3.7	52.9	4.0		
52.0	44.7	1.7	47.0	2.2	49.2	2.8	49.8	3.0		
54.0			44.1	1.4	46.2	1.9				
56.0										
危険角度 (°)	39		40		41		45		60	
フック種類	12t		12t		12t		12t		12t	
フック質量 (t)	0.42		0.42		0.42		0.42		0.42	
巻掛本数	1		1		1		1		1	

SA 性能

40.9m ブーム +1.5m+27.3mSL

ブーム オフセット 作業半径 (m)	40.9m ブーム 27.3mSL(5°)		40.9m ブーム 27.3mSL(15°)		40.9m ブーム 27.3mSL(30°)		40.9m ブーム 27.3mSL(45°)		40.9m ブーム 27.3mSL(60°)	
	ブーム角 (°)	荷重 (ton)	ブーム角 (°)	荷重 (ton)	ブーム角 (°)	荷重 (ton)	ブーム角 (°)	荷重 (ton)	ブーム角 (°)	荷重 (ton)
14.0	80.4	7.0								
16.0	78.9	7.0								
18.0	77.4	7.0	81.3	7.0						
20.0	75.9	7.0	79.7	6.9						
22.0	74.3	7.0	78.0	6.5						
24.0	72.7	7.0	76.3	6.1	81.2	4.6				
26.0	71.1	7.0	74.6	5.8	79.3	4.3				
28.0	69.4	6.7	72.8	5.4	77.4	4.1	81.5	3.3		
30.0	67.7	6.3	71.0	5.2	75.6	4.0	79.5	3.2		
32.0	65.8	5.9	69.2	4.9	73.8	3.8	77.5	3.1	80.3	2.7
34.0	64.0	5.6	67.3	4.6	71.8	3.6	75.4	3.0	78.0	2.6
36.0	62.1	5.3	65.4	4.4	69.8	3.5	73.4	2.9	75.6	2.6
38.0	60.2	5.0	63.4	4.2	67.8	3.4	71.1	2.9	73.1	2.6
40.0	58.2	4.7	61.5	4.0	65.7	3.3	68.8	2.8	70.6	2.5
42.0	56.1	4.4	59.4	3.8	63.5	3.1	66.4	2.7	67.9	2.5
44.0	54.1	4.2	57.3	3.6	61.2	3.0	64.1	2.7	65.1	2.5
46.0	51.9	4.0	55.0	3.5	58.8	2.9	61.5	2.6		
48.0	49.7	3.8	52.8	3.4	56.5	2.9	58.7	2.6		
50.0	47.3	3.6	50.3	3.2	53.9	2.8	55.7	2.6		
52.0	44.8	3.5	47.8	3.1	51.1	2.7	52.6	2.5		
54.0	42.2	3.2	45.1	3.0	48.2	2.7				
56.0	39.4	2.5	42.2	2.9	45.0	2.6				
58.0	36.2	1.9	39.0	2.3	41.4	2.6				
60.0	32.7	1.3	35.4	1.7	37.3	2.1				
62.0										
危険角度 (°)	27		27		30		45		60	
フック種類	12t		12t		12t		12t		12t	
フック質量 (t)	0.42		0.42		0.42		0.42		0.42	
巻掛本数	1		1		1		1		1	

SA 性能

45.5m ブーム +1.5m+27.3mSL

ブーム オフセット 作業半径 (m)	45.5m ブーム 27.3mSL(5°)		45.5m ブーム 27.3mSL(15°)		45.5m ブーム 27.3mSL(30°)		45.5m ブーム 27.3mSL(45°)		45.5m ブーム 27.3mSL(60°)	
	ブーム角 (°)	荷重 (ton)	ブーム角 (°)	荷重 (ton)	ブーム角 (°)	荷重 (ton)	ブーム角 (°)	荷重 (ton)	ブーム角 (°)	荷重 (ton)
14.0	81.3	7.0								
16.0	80.0	7.0								
18.0	78.6	7.0								
20.0	77.2	7.0	80.7	7.0						
22.0	75.8	7.0	79.3	6.7						
24.0	74.3	7.0	77.7	6.3						
26.0	72.9	7.0	76.2	6.0	80.5	4.4				
28.0	71.4	7.0	74.5	5.6	78.8	4.2				
30.0	69.8	6.6	72.9	5.4	77.2	4.1	80.7	3.3		
32.0	68.2	6.3	71.2	5.1	75.4	3.9	78.9	3.2	81.4	2.7
34.0	66.5	5.9	69.5	4.8	73.6	3.7	77.1	3.1	79.4	2.7
36.0	64.9	5.6	67.8	4.6	71.9	3.6	75.1	3.0	77.3	2.6
38.0	63.1	5.3	66.1	4.4	70.1	3.5	73.2	2.9	75.1	2.6
40.0	61.4	5.0	64.3	4.2	68.2	3.4	71.2	2.8	72.9	2.5
42.0	59.6	4.8	62.5	4.0	66.2	3.2	69.2	2.8	70.6	2.5
44.0	57.7	4.5	60.6	3.8	64.3	3.1	67.0	2.7	68.1	2.5
46.0	55.8	4.3	58.7	3.7	62.3	3.0	64.8	2.7	65.7	2.5
48.0	53.8	4.1	56.7	3.5	60.2	3.0	62.4	2.6		
50.0	51.8	3.9	54.6	3.4	58.0	2.9	60.0	2.6		
52.0	49.6	3.6	52.5	3.3	55.7	2.8	57.5	2.6		
54.0	47.4	2.9	50.2	3.2	53.2	2.7	54.7	2.5		
56.0	45.0	2.2	47.8	2.8	50.7	2.7	51.8	2.5		
58.0	42.3	1.6	45.3	2.1	47.9	2.6				
60.0			42.4	1.5	44.9	2.1				
62.0					41.4	1.4				
危険角度 (°)	34		36		36		45		60	
フック種類	12t		12t		12t		12t		12t	
フック質量 (t)	0.42		0.42		0.42		0.42		0.42	
巻掛本数	1		1		1		1		1	

SA 性能

50.0m ブーム +1.5m+27.3mSL

ブーム オフセット 作業半径 (m)	50.0m ブーム 27.3mSL(5°)		50.0m ブーム 27.3mSL(15°)		50.0m ブーム 27.3mSL(30°)		50.0m ブーム 27.3mSL(45°)		50.0m ブーム 27.3mSL(60°)	
	ブーム角 (°)	荷重 (ton)	ブーム角 (°)	荷重 (ton)	ブーム角 (°)	荷重 (ton)	ブーム角 (°)	荷重 (ton)	ブーム角 (°)	荷重 (ton)
16.0	80.5	7.0								
18.0	79.2	7.0								
20.0	78.0	7.0	81.3	7.0						
22.0	76.6	7.0	80.0	6.9						
24.0	75.3	7.0	78.5	6.5						
26.0	74.0	7.0	77.0	6.1	81.1	4.5				
28.0	72.7	7.0	75.6	5.8	79.6	4.3				
30.0	71.3	7.0	74.2	5.6	78.0	4.1	81.3	3.3		
32.0	69.8	6.6	72.7	5.3	76.5	4.0	79.7	3.2		
34.0	68.3	6.2	71.0	5.0	74.9	3.8	78.0	3.1	80.2	2.7
36.0	66.7	5.9	69.5	4.8	73.2	3.7	76.3	3.0	78.3	2.6
38.0	65.2	5.6	67.9	4.6	71.6	3.6	74.4	2.9	76.4	2.6
40.0	63.6	5.3	66.2	4.4	69.8	3.4	72.7	2.9	74.4	2.6
42.0	61.9	5.1	64.6	4.2	68.1	3.3	70.8	2.8	72.3	2.5
44.0	60.3	4.8	62.9	4.0	66.3	3.2	68.9	2.7	70.2	2.5
46.0	58.6	4.6	61.2	3.9	64.5	3.1	67.0	2.7	68.0	2.5
48.0	56.8	4.4	59.4	3.7	62.7	3.0	65.0	2.7	65.6	2.5
50.0	54.9	4.1	57.6	3.6	60.8	3.0	62.8	2.6		
52.0	53.0	3.3	55.6	3.4	58.8	2.9	60.6	2.6		
54.0	50.9	2.6	53.6	3.3	56.6	2.8	58.3	2.5		
56.0	48.7	1.9	51.6	2.6	54.4	2.8	55.8	2.5		
58.0	46.3	1.3	49.3	2.0	52.2	2.7	53.1	2.5		
60.0			46.8	1.3	49.7	2.0	50.3	2.3		
62.0					46.8	1.3				
危険角度 (°)	41		41		42		45		60	
フック種類	12t		12t		12t		12t		12t	
フック質量 (t)	0.42		0.42		0.42		0.42		0.42	
巻掛本数	1		1		1		1		1	

SB 性能

40.9m ブーム +1.5m+10.5mSL

ブーム オフセット 作業半径 (m)	40.9m ブーム 10.5mSL(5°)		40.9m ブーム 10.5mSL(15°)		40.9m ブーム 10.5mSL(30°)		40.9m ブーム 10.5mSL(45°)		40.9m ブーム 10.5mSL(60°)	
	ブーム角 (°)	荷重 (ton)	ブーム角 (°)	荷重 (ton)	ブーム角 (°)	荷重 (ton)	ブーム角 (°)	荷重 (ton)	ブーム角 (°)	荷重 (ton)
9.0	80.6	24.0								
10.0	79.5	24.0	81.4	24.0						
11.0	78.5	24.0	80.4	23.3						
12.0	77.5	24.0	79.4	22.4						
14.0	75.5	24.0	77.2	20.9	79.4	16.6	81.2	13.8		
16.0	73.4	23.9	75.0	19.5	77.1	15.9	78.9	13.4	80.0	11.2
18.0	71.2	22.0	72.7	18.3	74.9	15.2	76.5	13.1	77.5	11.0
20.0	69.0	20.3	70.4	17.2	72.6	14.6	74.2	12.7	74.9	10.9
22.0	66.7	18.9	68.1	16.2	70.2	14.1	71.7	12.4	72.3	10.8
24.0	64.2	16.9	65.7	15.4	67.7	13.6	69.1	12.2	69.7	10.7
26.0	61.6	14.2	63.3	14.6	65.2	13.1	66.5	12.0	66.9	10.7
28.0	58.9	12.0	60.7	12.5	62.6	12.7	63.8	11.8	64.0	10.7
30.0	56.2	10.1	57.9	10.6	59.8	11.2	61.0	11.6		
32.0	53.3	8.5	55.0	8.9	56.8	9.4	57.8	9.7		
34.0	50.3	6.9	52.0	7.4	53.7	7.9	54.5	8.1		
36.0	47.2	5.4	48.8	5.9	50.4	6.4	51.1	6.6		
38.0	43.9	4.0	45.5	4.4	46.9	4.8				
40.0	40.4	2.7	41.9	3.1	43.1	3.5				
42.0										
44.0										
46.0										
危険角度 (°)		35		36		37		45		60
フック種類		24t		24t		24t		24t		24t
フック質量 (t)		0.88		0.88		0.88		0.88		0.88
巻掛本数		2		2		2		2		2

SB 性能

45.5m ブーム +1.5m+10.5mSL

ブーム オフセット 作業半径 (m)	45.5m ブーム 10.5mSL(5°)		45.5m ブーム 10.5mSL(15°)		45.5m ブーム 10.5mSL(30°)		45.5m ブーム 10.5mSL(45°)		45.5m ブーム 10.5mSL(60°)	
	ブーム角 (°)	荷重 (ton)	ブーム角 (°)	荷重 (ton)	ブーム角 (°)	荷重 (ton)	ブーム角 (°)	荷重 (ton)	ブーム角 (°)	荷重 (ton)
10.0	80.7	24.0								
11.0	79.9	24.0								
12.0	78.9	24.0	80.6	23.2						
14.0	77.2	24.0	78.8	21.6	80.7	16.9				
16.0	75.4	24.0	76.8	20.3	78.7	16.2	80.3	13.6	81.3	11.2
18.0	73.5	23.4	74.8	19.0	76.6	15.6	78.3	13.2	79.2	11.1
20.0	71.5	21.6	72.8	18.0	74.6	15.0	76.1	12.9	76.9	10.9
22.0	69.4	20.2	70.7	17.0	72.5	14.4	74.0	12.6	74.6	10.8
24.0	67.1	16.9	68.6	16.1	70.4	14.0	71.7	12.4	72.4	10.8
26.0	64.8	14.2	66.4	14.8	68.2	13.5	69.5	12.1	69.9	10.7
28.0	62.4	11.9	63.9	12.5	65.9	13.1	67.1	11.9	67.5	10.7
30.0	59.9	10.0	61.4	10.5	63.4	11.2	64.8	11.7	64.9	10.7
32.0	57.3	8.4	59.0	8.9	60.8	9.5	62.0	9.8		
34.0	54.7	6.9	56.3	7.4	58.1	7.9	59.2	8.2		
36.0	52.0	5.3	53.6	5.8	55.3	6.5	56.2	6.8		
38.0	49.2	3.9	50.7	4.4	52.2	4.9	53.1	5.2		
40.0	46.2	2.7	47.7	3.1	49.1	3.5				
42.0										
44.0										
46.0										
危険角度 (°)		41		42		43		45		60
フック種類		24t		24t		24t		24t		24t
フック質量 (t)		0.88		0.88		0.88		0.88		0.88
巻掛本数		2		2		2		2		2

SB 性能

50.0m ブーム +1.5m+10.5mSL

ブーム オフセット 作業半径 (m)	50.0m ブーム 10.5mSL(5°)		50.0m ブーム 10.5mSL(15°)		50.0m ブーム 10.5mSL(30°)		50.0m ブーム 10.5mSL(45°)		50.0m ブーム 10.5mSL(60°)	
	ブーム角 (°)	荷重 (ton)	ブーム角 (°)	荷重 (ton)	ブーム角 (°)	荷重 (ton)	ブーム角 (°)	荷重 (ton)	ブーム角 (°)	荷重 (ton)
11.0	80.8	20.0								
12.0	80.1	20.0	81.7	20.0						
14.0	78.5	20.0	80.0	20.0						
16.0	76.8	20.0	78.4	20.0	80.1	16.5	81.5	13.7		
18.0	75.2	20.0	76.7	19.7	78.3	15.9	79.7	13.4	80.4	11.1
20.0	73.5	20.0	74.9	18.7	76.5	15.3	77.7	13.0	78.4	11.0
22.0	71.8	20.0	73.1	17.7	74.7	14.8	75.8	12.8	76.4	10.9
24.0	69.7	16.8	71.1	16.8	72.7	14.3	73.8	12.5	74.4	10.8
26.0	67.5	14.1	69.1	14.8	70.8	13.9	71.9	12.3	72.2	10.7
28.0	65.3	11.8	66.8	12.5	68.8	13.3	69.8	12.1	70.1	10.7
30.0	63.0	10.0	64.6	10.5	66.4	11.2	67.6	11.7	67.9	10.6
32.0	60.7	8.3	62.3	8.8	64.0	9.5	65.2	9.9		
34.0	58.4	6.8	59.9	7.4	61.6	7.9	62.7	8.3		
36.0	56.0	5.2	57.5	5.8	59.1	6.5	60.1	6.9		
38.0	53.5	3.8	54.9	4.3	56.5	5.0	57.3	5.3		
40.0	50.8	2.6	52.3	3.0	53.8	3.6	54.4	3.9		
42.0							51.5	2.6		
44.0										
46.0										
危険角度 (°)		46		47		47		47		60
フック種類		24t		24t		24t		24t		24t
フック質量 (t)		0.88		0.88		0.88		0.88		0.88
巻掛本数		2		2		2		2		2

SB 性能

40.9m ブーム +1.5m+18.9mSL

オフセット 作業半径 (m)	40.9m ブーム 18.9mSL(5°)		40.9m ブーム 18.9mSL(15°)		40.9m ブーム 18.9mSL(30°)		40.9m ブーム 18.9mSL(45°)		40.9m ブーム 18.9mSL(60°)	
	ブーム角 (°)	荷重 (ton)	ブーム角 (°)	荷重 (ton)	ブーム角 (°)	荷重 (ton)	ブーム角 (°)	荷重 (ton)	ブーム角 (°)	荷重 (ton)
10.0	81.5	10.0								
11.0	80.6	10.0								
12.0	79.8	10.0								
14.0	78.0	10.0	81.0	10.0						
16.0	76.2	10.0	79.2	10.0						
18.0	74.4	10.0	77.3	10.0	81.1	8.1				
20.0	72.5	10.0	75.5	10.0	79.2	7.7				
22.0	70.7	10.0	73.6	9.7	77.1	7.3	80.2	6.0		
24.0	68.9	10.0	71.5	9.1	75.1	7.0	78.0	5.8	80.1	5.1
26.0	66.9	10.0	69.5	8.6	73.0	6.8	75.8	5.7	77.6	5.1
28.0	64.9	9.7	67.5	8.2	70.8	6.5	73.6	5.5	75.2	5.0
30.0	62.8	9.1	65.4	7.8	68.6	6.3	71.2	5.4	72.7	4.9
32.0	60.7	8.6	63.1	7.4	66.4	6.1	68.8	5.3	70.1	4.9
34.0	58.4	8.1	60.9	7.1	64.0	5.9	66.3	5.2	67.3	4.9
36.0	56.1	7.6	58.6	6.8	61.7	5.7	63.7	5.1	64.5	4.8
38.0	53.6	7.1	56.2	6.5	59.1	5.5	61.0	5.0		
40.0	51.0	6.6	53.7	6.2	56.5	5.4	58.2	4.9		
42.0	48.3	6.1	50.9	5.9	53.9	5.3	55.2	4.9		
44.0	45.4	5.6	48.0	5.6	50.8	5.1	51.9	4.9		
46.0	42.4	5.1	44.9	5.3	47.5	4.9				
48.0	39.2	4.6	41.6	5.0	44.0	4.7				
50.0					40.0	4.5				
52.0						4.3				
54.0										
56.0										
危険角度 (°)	35		36		37		45		60	
フック種類	12t		12t		12t		12t		12t	
フック質量 (t)	0.42		0.42		0.42		0.42		0.42	
巻掛本数	1		1		1		1		1	

SB 性能

45.5m ブーム +1.5m+18.9mSL

オフセット 作業半径 (m)	45.5m ブーム 18.9mSL(5°)		45.5m ブーム 18.9mSL(15°)		45.5m ブーム 18.9mSL(30°)		45.5m ブーム 18.9mSL(45°)		45.5m ブーム 18.9mSL(60°)	
	ブーム角 (°)	荷重 (ton)	ブーム角 (°)	荷重 (ton)	ブーム角 (°)	荷重 (ton)	ブーム角 (°)	荷重 (ton)	ブーム角 (°)	荷重 (ton)
11.0	81.4	10.0								
12.0	80.6	10.0								
14.0	79.0	10.0								
16.0	77.4	10.0	80.3	10.0						
18.0	75.8	10.0	78.5	10.0						
20.0	74.2	10.0	76.9	10.0	80.3	7.8				
22.0	72.5	10.0	75.2	10.0	78.5	7.5	81.3	6.1		
24.0	70.9	10.0	73.4	9.5	76.6	7.2	79.3	5.9	81.2	5.2
26.0	69.2	10.0	71.6	9.0	74.7	6.9	77.3	5.7	79.1	5.1
28.0	67.4	10.0	69.7	8.6	72.8	6.7	75.2	5.6	76.9	5.0
30.0	65.5	9.8	67.9	8.1	70.9	6.5	73.2	5.5	74.6	5.0
32.0	63.6	9.2	65.9	7.8	68.8	6.2	71.1	5.4	72.4	4.9
34.0	61.7	8.7	63.9	7.4	66.8	6.1	68.9	5.3	70.0	4.9
36.0	59.5	8.1	61.8	7.1	64.7	5.9	66.7	5.2	67.5	4.8
38.0	57.2	7.6	59.8	6.8	62.5	5.7	64.3	5.1	65.0	4.8
40.0	54.9	7.1	57.5	6.5	60.3	5.6	61.9	5.0		
42.0	52.4	6.6	55.0	6.2	57.9	5.4	59.4	4.9		
44.0	49.9	6.1	52.4	5.9	55.3	5.2	56.7	4.9		
46.0	47.3	5.6	49.8	5.6	52.5	5.0	53.7	4.8		
48.0	44.6	5.1	46.9	5.3	49.5	4.8	50.5	4.7		
50.0					46.4	4.6				
52.0						4.4				
54.0										
56.0										
危険角度 (°)	41		42		43		45		60	
フック種類	12t		12t		12t		12t		12t	
フック質量 (t)	0.42		0.42		0.42		0.42		0.42	
巻掛本数	1		1		1		1		1	

SB 性能

50.0m ブーム +1.5m+18.9mSL

オフセット 作業半径 (m)	50.0m ブーム 18.9mSL(5°)		50.0m ブーム 18.9mSL(15°)		50.0m ブーム 18.9mSL(30°)		50.0m ブーム 18.9mSL(45°)		50.0m ブーム 18.9mSL(60°)	
	ブーム角 (°)	荷重 (ton)	ブーム角 (°)	荷重 (ton)	ブーム角 (°)	荷重 (ton)	ブーム角 (°)	荷重 (ton)	ブーム角 (°)	荷重 (ton)
12.0	81.5	10.0								
14.0	80.0	10.0								
16.0	78.6	10.0	81.2	10.0						
18.0	77.2	10.0	79.7	10.0						
20.0	75.6	10.0	78.2	10.0	81.3	8.0				
22.0	74.2	10.0	76.7	10.0	79.7	7.6				
24.0	72.7	10.0	75.2	9.9	78.0	7.4	80.4	6.0		
26.0	71.1	10.0	73.5	9.4	76.3	7.1	78.6	5.8	80.3	5.1
28.0	69.6	10.0	71.8	8.9	74.6	6.8	76.9	5.7	78.3	5.0
30.0	68.0	10.0	70.1	8.5	72.8	6.6	75.0	5.5	76.3	5.0
32.0	66.3	9.4	68.4	8.1	71.0	6.4	73.1	5.4	74.4	4.9
34.0	64.4	8.9	66.6	7.8	69.2	6.2	71.1	5.3	72.3	4.9
36.0	62.5	8.4	64.8	7.4	67.4	6.0	69.2	5.2	70.1	4.8
38.0	60.4	7.9	62.9	7.1	65.4	5.9	67.2	5.1	67.9	4.8
40.0	58.3	7.4	60.8	6.8	63.4	5.7	65.1	5.0	65.6	4.8
42.0	56.1	6.9	58.5	6.5	61.4	5.6	62.9	5.0		
44.0	53.9	6.4	56.3	6.2	59.1	5.4	60.6	4.9		
46.0	51.5	5.9	53.9	5.9	56.7	5.2	58.1	4.8		
48.0			51.5	5.6	54.1	5.0	55.3	4.7		
50.0					51.4	4.8	52.4	4.6		
52.0						4.6				
54.0										
56.0										
危険角度 (°)	46		47		47		47		60	
フック種類	12t		12t		12t		12t		12t	
フック質量 (t)	0.42		0.42		0.42		0.42		0.42	
巻掛本数	1		1		1		1		1	

SB 性能

40.9m ブーム +1.5m+27.3mSL

ブーム オフセット 作業半径 (m)	40.9m ブーム 27.3mSL(5°)		40.9m ブーム 27.3mSL(15°)		40.9m ブーム 27.3mSL(30°)		40.9m ブーム 27.3mSL(45°)		40.9m ブーム 27.3mSL(60°)	
	ブーム角 (°)	荷重 (ton)	ブーム角 (°)	荷重 (ton)	ブーム角 (°)	荷重 (ton)	ブーム角 (°)	荷重 (ton)	ブーム角 (°)	荷重 (ton)
14.0	80.4	7.0								
16.0	78.9	7.0								
18.0	77.4	7.0	81.3	7.0						
20.0	75.9	7.0	79.7	6.9						
22.0	74.3	7.0	78.0	6.5						
24.0	72.7	7.0	76.3	6.1	81.2	4.6				
26.0	71.1	7.0	74.6	5.8	79.3	4.3				
28.0	69.4	6.7	72.8	5.4	77.4	4.1	81.5	3.3		
30.0	67.7	6.3	71.0	5.2	75.6	4.0	79.5	3.2		
32.0	65.8	5.9	69.2	4.9	73.8	3.8	77.5	3.1	80.3	2.7
34.0	64.0	5.6	67.3	4.6	71.8	3.6	75.4	3.0	78.0	2.6
36.0	62.1	5.3	65.4	4.4	69.8	3.5	73.4	2.9	75.6	2.6
38.0	60.2	5.0	63.4	4.2	67.8	3.4	71.1	2.9	73.1	2.6
40.0	58.2	4.7	61.5	4.0	65.7	3.3	68.8	2.8	70.6	2.5
42.0	56.1	4.4	59.4	3.8	63.5	3.1	66.4	2.7	67.9	2.5
44.0	54.1	4.2	57.3	3.6	61.2	3.0	64.1	2.7	65.1	2.5
46.0	51.9	4.0	55.0	3.5	58.8	2.9	61.5	2.6		
48.0	49.6	3.5	52.8	3.4	56.5	2.9	58.7	2.6		
50.0	47.0	2.7	50.3	3.2	53.9	2.8	55.7	2.6		
52.0	44.2	2.0	47.6	2.6	51.1	2.7	52.6	2.5		
54.0	41.4	1.3	44.6	1.9	48.2	2.6				
56.0					44.7	1.8				
58.0										
60.0										
62.0										
危険角度 (°)	37		37		38		45		60	
フック種類	12t		12t		12t		12t		12t	
フック質量 (t)	0.42		0.42		0.42		0.42		0.42	
巻掛本数	1		1		1		1		1	

SB 性能

45.5m ブーム +1.5m+27.3mSL

ブーム オフセット 作業半径 (m)	45.5m ブーム 27.3mSL(5°)		45.5m ブーム 27.3mSL(15°)		45.5m ブーム 27.3mSL(30°)		45.5m ブーム 27.3mSL(45°)		45.5m ブーム 27.3mSL(60°)	
	ブーム角 (°)	荷重 (ton)	ブーム角 (°)	荷重 (ton)	ブーム角 (°)	荷重 (ton)	ブーム角 (°)	荷重 (ton)	ブーム角 (°)	荷重 (ton)
14.0	81.3	7.0								
16.0	80.0	7.0								
18.0	78.6	7.0								
20.0	77.2	7.0	80.7	7.0						
22.0	75.8	7.0	79.3	6.7						
24.0	74.3	7.0	77.7	6.3						
26.0	72.9	7.0	76.2	6.0	80.5	4.4				
28.0	71.4	7.0	74.5	5.6	78.8	4.2				
30.0	69.8	6.6	72.9	5.4	77.2	4.1	80.7	3.3		
32.0	68.2	6.3	71.2	5.1	75.4	3.9	78.9	3.2	81.4	2.7
34.0	66.5	5.9	69.5	4.8	73.6	3.7	77.1	3.1	79.4	2.7
36.0	64.9	5.6	67.8	4.6	71.9	3.6	75.1	3.0	77.3	2.6
38.0	63.1	5.3	66.1	4.4	70.1	3.5	73.2	2.9	75.1	2.6
40.0	61.4	5.0	64.3	4.2	68.2	3.4	71.2	2.8	72.9	2.5
42.0	59.6	4.8	62.5	4.0	66.2	3.2	69.2	2.8	70.6	2.5
44.0	57.7	4.5	60.6	3.8	64.3	3.1	67.0	2.7	68.1	2.5
46.0	55.7	4.0	58.7	3.7	62.3	3.0	64.8	2.7	65.7	2.5
48.0	53.4	3.2	56.7	3.5	60.2	3.0	62.4	2.6		
50.0	51.1	2.4	54.5	3.2	58.0	2.9	60.0	2.6		
52.0	48.8	1.7	52.1	2.4	55.7	2.8	57.5	2.6		
54.0			49.6	1.7	53.2	2.6	54.7	2.5		
56.0					50.3	1.8	51.7	2.2		
58.0										
60.0										
62.0										
危険角度 (°)	44		44		45		45		60	
フック種類	12t		12t		12t		12t		12t	
フック質量 (t)	0.42		0.42		0.42		0.42		0.42	
巻掛本数	1		1		1		1		1	

SB 性能

50.0m ブーム +1.5m+27.3mSL

ブーム オフセット 作業半径 (m)	50.0m ブーム 27.3mSL(5°)		50.0m ブーム 27.3mSL(15°)		50.0m ブーム 27.3mSL(30°)		50.0m ブーム 27.3mSL(45°)		50.0m ブーム 27.3mSL(60°)	
	ブーム角 (°)	荷重 (ton)	ブーム角 (°)	荷重 (ton)	ブーム角 (°)	荷重 (ton)	ブーム角 (°)	荷重 (ton)	ブーム角 (°)	荷重 (ton)
16.0	80.5	7.0								
18.0	79.2	7.0								
20.0	78.0	7.0	81.3	7.0						
22.0	76.6	7.0	80.0	6.9						
24.0	75.3	7.0	78.5	6.5						
26.0	74.0	7.0	77.0	6.1	81.1	4.5				
28.0	72.7	7.0	75.6	5.8	79.6	4.3				
30.0	71.3	7.0	74.2	5.6	78.0	4.1	81.3	3.3		
32.0	69.8	6.6	72.7	5.3	76.5	4.0	79.7	3.2		
34.0	68.3	6.2	71.0	5.0	74.9	3.8	78.0	3.1	80.2	2.7
36.0	66.7	5.9	69.5	4.8	73.2	3.7	76.3	3.0	78.3	2.6
38.0	65.2	5.6	67.9	4.6	71.6	3.6	74.4	2.9	76.4	2.6
40.0	63.6	5.3	66.2	4.4	69.8	3.4	72.7	2.9	74.4	2.6
42.0	61.9	5.1	64.6	4.2	68.1	3.3	70.8	2.8	72.3	2.5
44.0	60.2	4.7	62.9	4.0	66.3	3.2	68.9	2.7	70.2	2.5
46.0	58.2	3.7	61.2	3.9	64.5	3.1	67.0	2.7	68.0	2.5
48.0	56.1	2.9	59.4	3.7	62.7	3.0	65.0	2.7	65.6	2.5
50.0	54.0	2.1	57.3	3.0	60.8	3.0	62.8	2.6		
52.0	51.8	1.4	55.1	2.2	58.8	2.9	60.6	2.6		
54.0			52.8	1.5	56.5	2.5	58.3	2.5		
56.0					53.9	1.7	55.7	2.2		
58.0							52.8	1.4		
60.0										
62.0										
危険角度 (°)	48		48		48		49		60	
フック種類	12t		12t		12t		12t		12t	
フック質量 (t)	0.42		0.42		0.42		0.42		0.42	
巻掛本数	1		1		1		1		1	

SC 性能

40.9m ブーム +1.5m+10.5mSL

ブーム オフセット 作業半径 (m)	40.9m ブーム 10.5mSL(5°)		40.9m ブーム 10.5mSL(15°)		40.9m ブーム 10.5mSL(30°)		40.9m ブーム 10.5mSL(45°)		40.9m ブーム 10.5mSL(60°)	
	ブーム角 (°)	荷重 (ton)	ブーム角 (°)	荷重 (ton)	ブーム角 (°)	荷重 (ton)	ブーム角 (°)	荷重 (ton)	ブーム角 (°)	荷重 (ton)
9.0	80.6	24.0								
10.0	79.5	24.0	81.4	24.0						
11.0	78.5	24.0	80.4	23.3						
12.0	77.5	24.0	79.4	22.4						
14.0	75.5	24.0	77.2	20.9	79.4	16.6	81.2	13.8		
16.0	73.4	23.9	75.0	19.5	77.1	15.9	78.9	13.4	80.0	11.2
18.0	71.1	21.3	72.7	18.3	74.9	15.2	76.5	13.1	77.5	11.0
20.0	68.7	17.2	70.4	17.2	72.6	14.6	74.2	12.7	74.9	10.9
22.0	66.2	14.0	68.0	14.8	70.2	14.1	71.7	12.4	72.3	10.8
24.0	63.7	11.5	65.4	12.2	67.7	13.1	69.1	12.2	69.7	10.7
26.0	61.1	9.4	62.8	10.0	65.0	10.8	66.4	11.3	66.9	10.7
28.0	58.5	7.6	60.2	8.1	62.2	8.8	63.6	9.3	63.9	9.5
30.0	55.7	5.7	57.4	6.4	59.3	7.2	60.6	7.6		
32.0	52.8	4.0	54.5	4.7	56.3	5.4	57.4	5.8		
34.0	49.8	2.6	51.4	3.1	53.2	3.8	54.1	4.1		
36.0					49.9	2.3	50.6	2.6		
38.0										
40.0										
42.0										
44.0										
46.0										
危険角度 (°)	46		47		47		47		60	
フック種類	24t		24t		24t		24t		24t	
フック質量 (t)	0.88		0.88		0.88		0.88		0.88	
巻掛本数	2		2		2		2		2	

SC 性能

45.5m ブーム +1.5m+10.5mSL

ブーム オフセット 作業半径 (m)	45.5m ブーム 10.5mSL(5°)		45.5m ブーム 10.5mSL(15°)		45.5m ブーム 10.5mSL(30°)		45.5m ブーム 10.5mSL(45°)		45.5m ブーム 10.5mSL(60°)	
	ブーム角 (°)	荷重 (ton)	ブーム角 (°)	荷重 (ton)	ブーム角 (°)	荷重 (ton)	ブーム角 (°)	荷重 (ton)	ブーム角 (°)	荷重 (ton)
10.0	80.7	24.0								
11.0	79.9	24.0								
12.0	78.9	24.0	80.6	23.2						
14.0	77.2	24.0	78.8	21.6	80.7	16.9				
16.0	75.4	24.0	76.8	20.3	78.7	16.2	80.3	13.6	81.3	11.2
18.0	73.4	21.3	74.8	19.0	76.6	15.6	78.3	13.2	79.2	11.1
20.0	71.0	17.2	72.8	18.0	74.6	15.0	76.1	12.9	76.9	10.9
22.0	68.7	14.0	70.5	14.8	72.5	14.4	74.0	12.6	74.6	10.8
24.0	66.4	11.4	68.1	12.1	70.3	13.1	71.7	12.4	72.4	10.8
26.0	64.2	9.3	65.8	10.0	67.9	10.8	69.4	11.4	69.9	10.7
28.0	61.8	7.5	63.3	8.1	65.4	8.9	66.8	9.4	67.3	9.6
30.0	59.3	5.6	60.8	6.4	62.8	7.2	64.2	7.6		
32.0	56.7	4.0	58.3	4.6	60.2	5.5	61.5	6.0		
34.0	54.0	2.5	55.6	3.1	57.4	3.8	58.6	4.3		
36.0					54.6	2.4	55.6	2.7		
38.0										
40.0										
42.0										
44.0										
46.0										
危険角度 (°)	52		52		52		52		60	
フック種類	24t		24t		24t		24t		24t	
フック質量 (t)	0.88		0.88		0.88		0.88		0.88	
巻掛本数	2		2		2		2		2	

SC 性能

50.0m ブーム +1.5m+10.5mSL

ブーム オフセット 作業半径 (m)	50.0m ブーム 10.5mSL(5°)		50.0m ブーム 10.5mSL(15°)		50.0m ブーム 10.5mSL(30°)		50.0m ブーム 10.5mSL(45°)		50.0m ブーム 10.5mSL(60°)	
	ブーム角 (°)	荷重 (ton)	ブーム角 (°)	荷重 (ton)	ブーム角 (°)	荷重 (ton)	ブーム角 (°)	荷重 (ton)	ブーム角 (°)	荷重 (ton)
11.0	80.8	20.0								
12.0	80.1	20.0								
14.0	78.5	20.0	80.0	20.0						
16.0	76.8	20.0	78.4	20.0	80.1	16.5	81.5	13.7		
18.0	75.2	20.0	76.7	19.7	78.3	15.9	79.7	13.4	80.4	11.1
20.0	73.1	17.1	74.9	18.1	76.5	15.3	77.7	13.0	78.4	11.0
22.0	71.0	13.9	72.7	14.8	74.7	14.8	75.8	12.8	76.4	10.9
24.0	68.9	11.3	70.5	12.1	72.6	13.1	73.8	12.5	74.4	10.8
26.0	66.8	9.2	68.4	9.9	70.3	10.8	71.8	11.4	72.2	10.7
28.0	64.6	7.5	66.1	8.1	68.0	8.9	69.3	9.4	70.0	9.7
30.0	62.3	5.5	63.9	6.3	65.7	7.2	66.9	7.7	67.5	7.9
32.0	60.0	3.9	61.5	4.6	63.3	5.5	64.5	6.1		
34.0			59.1	3.1	60.8	3.8	61.9	4.3		
36.0							59.3	2.8		
38.0										
40.0										
42.0										
44.0										
46.0										
危険角度 (°)	57		57		57		57		60	
フック種類	24t		24t		24t		24t		24t	
フック質量 (t)	0.88		0.88		0.88		0.88		0.88	
巻掛本数	2		2		2		2		2	

SC 性能

40.9m ブーム +1.5m+18.9mSL

オフセット 作業半径 (m)	40.9m ブーム 18.9mSL(5°)		40.9m ブーム 18.9mSL(15°)		40.9m ブーム 18.9mSL(30°)		40.9m ブーム 18.9mSL(45°)		40.9m ブーム 18.9mSL(60°)	
	ブーム角 (°)	荷重 (ton)	ブーム角 (°)	荷重 (ton)	ブーム角 (°)	荷重 (ton)	ブーム角 (°)	荷重 (ton)	ブーム角 (°)	荷重 (ton)
10.0	81.5	10.0								
11.0	80.6	10.0								
12.0	79.8	10.0								
14.0	78.0	10.0	81.0	10.0						
16.0	76.2	10.0	79.2	10.0						
18.0	74.4	10.0	77.3	10.0	81.1	8.1				
20.0	72.5	10.0	75.5	10.0	79.2	7.7				
22.0	70.7	10.0	73.6	9.7	77.1	7.3	80.2	6.0		
24.0	68.9	10.0	71.5	9.1	75.1	7.0	78.0	5.8	80.1	5.1
26.0	66.9	10.0	69.5	8.6	73.0	6.8	75.8	5.7	77.6	5.1
28.0	64.9	9.7	67.5	8.2	70.8	6.5	73.6	5.5	75.2	5.0
30.0	62.6	8.2	65.4	7.8	68.6	6.3	71.2	5.4	72.7	4.9
32.0	60.3	6.8	63.1	7.4	66.4	6.1	68.8	5.3	70.1	4.9
34.0	57.9	5.4	60.8	6.4	64.0	5.9	66.3	5.2	67.3	4.9
36.0	55.5	4.1	58.3	5.1	61.7	5.7	63.7	5.1	64.5	4.8
38.0	52.9	3.0	55.7	3.8	59.0	4.9	61.0	5.0		
40.0	50.2	1.9	53.0	2.7	56.2	3.7	58.1	4.3		
42.0			50.2	1.7	53.3	2.6	54.9	3.1		
44.0					50.2	1.5	51.4	1.9		
46.0										
48.0										
50.0										
52.0										
54.0										
56.0										
危険角度 (°)	46		47		47		47		60	
フック種類	12t		12t		12t		12t		12t	
フック質量 (t)	0.42		0.42		0.42		0.42		0.42	
巻掛本数	1		1		1		1		1	

SC 性能

45.5m ブーム +1.5m+18.9mSL

オフセット 作業半径 (m)	45.5m ブーム 18.9mSL(5°)		45.5m ブーム 18.9mSL(15°)		45.5m ブーム 18.9mSL(30°)		45.5m ブーム 18.9mSL(45°)		45.5m ブーム 18.9mSL(60°)	
	ブーム角 (°)	荷重 (ton)	ブーム角 (°)	荷重 (ton)	ブーム角 (°)	荷重 (ton)	ブーム角 (°)	荷重 (ton)	ブーム角 (°)	荷重 (ton)
11.0	81.4	10.0								
12.0	80.6	10.0								
14.0	79.0	10.0								
16.0	77.4	10.0	80.3	10.0						
18.0	75.8	10.0	78.5	10.0						
20.0	74.2	10.0	76.9	10.0	80.3	7.8				
22.0	72.5	10.0	75.2	10.0	78.5	7.5	81.3	6.1		
24.0	70.9	10.0	73.4	9.5	76.6	7.2	79.3	5.9	81.2	5.2
26.0	69.2	10.0	71.6	9.0	74.7	6.9	77.3	5.7	79.1	5.1
28.0	67.3	9.6	69.7	8.6	72.8	6.7	75.2	5.6	76.9	5.0
30.0	65.2	8.0	67.9	8.1	70.9	6.5	73.2	5.5	74.6	5.0
32.0	63.1	6.7	65.8	7.5	68.8	6.2	71.1	5.4	72.4	4.9
34.0	60.9	5.2	63.7	6.3	66.8	6.1	68.9	5.3	70.0	4.9
36.0	58.7	3.9	61.3	4.9	64.7	5.9	66.7	5.2	67.5	4.8
38.0	56.4	2.8	59.1	3.7	62.3	4.9	64.3	5.1	65.0	4.8
40.0	54.0	1.7	56.6	2.6	59.8	3.6	61.8	4.4		
42.0			54.2	1.6	57.3	2.5	59.0	3.1		
44.0					54.5	1.5	56.1	2.0		
46.0										
48.0										
50.0										
52.0										
54.0										
56.0										
危険角度 (°)	52		52		52		52		60	
フック種類	12t		12t		12t		12t		12t	
フック質量 (t)	0.42		0.42		0.42		0.42		0.42	
巻掛本数	1		1		1		1		1	

SC 性能

50.0m ブーム +1.5m+18.9mSL

オフセット 作業半径 (m)	50.0m ブーム 18.9mSL(5°)		50.0m ブーム 18.9mSL(15°)		50.0m ブーム 18.9mSL(30°)		50.0m ブーム 18.9mSL(45°)		50.0m ブーム 18.9mSL(60°)	
	ブーム角 (°)	荷重 (ton)	ブーム角 (°)	荷重 (ton)	ブーム角 (°)	荷重 (ton)	ブーム角 (°)	荷重 (ton)	ブーム角 (°)	荷重 (ton)
12.0	81.5	10.0								
14.0	80.0	10.0								
16.0	78.6	10.0	81.2	10.0						
18.0	77.2	10.0	79.7	10.0						
20.0	75.6	10.0	78.2	10.0	81.3	8.0				
22.0	74.2	10.0	76.7	10.0	79.7	7.6				
24.0	72.7	10.0	75.2	9.9	78.0	7.4	80.4	6.0		
26.0	71.1	10.0	73.5	9.4	76.3	7.1	78.6	5.8	80.3	5.1
28.0	69.5	9.4	71.8	8.9	74.6	6.8	76.9	5.7	78.3	5.0
30.0	67.6	7.9	70.1	8.5	72.8	6.6	75.0	5.5	76.3	5.0
32.0	65.7	6.5	68.2	7.4	71.0	6.4	73.1	5.4	74.4	4.9
34.0	63.6	5.0	66.2	6.2	69.2	6.2	71.1	5.3	72.3	4.9
36.0	61.6	3.7	64.1	4.8	67.4	6.0	69.2	5.2	70.1	4.8
38.0	59.4	2.6	62.0	3.5	65.1	4.8	67.2	5.1	67.9	4.8
40.0			59.8	2.4	62.9	3.6	64.9	4.4	65.6	4.8
42.0					60.6	2.5	62.5	3.2		
44.0					58.2	1.5	59.9	2.1		
46.0										
48.0										
50.0										
52.0										
54.0										
56.0										
危険角度 (°)	57		57		57		57		60	
フック種類	12t		12t		12t		12t		12t	
フック質量 (t)	0.42		0.42		0.42		0.42		0.42	
巻掛本数	1		1		1		1		1	

SC 性能

40.9m ブーム +1.5m+27.3mSL

ブーム オフセット 作業半径 (m)	40.9m ブーム 27.3mSL(5°)		40.9m ブーム 27.3mSL(15°)		40.9m ブーム 27.3mSL(30°)		40.9m ブーム 27.3mSL(45°)		40.9m ブーム 27.3mSL(60°)	
	ブーム角 (°)	荷重 (ton)	ブーム角 (°)	荷重 (ton)	ブーム角 (°)	荷重 (ton)	ブーム角 (°)	荷重 (ton)	ブーム角 (°)	荷重 (ton)
14.0	80.4	7.0								
16.0	78.9	7.0								
18.0	77.4	7.0	81.3	7.0						
20.0	75.9	7.0	79.7	6.9						
22.0	74.3	7.0	78.0	6.5						
24.0	72.7	7.0	76.3	6.1	81.2	4.6				
26.0	71.1	7.0	74.6	5.8	79.3	4.3				
28.0	69.4	6.7	72.8	5.4	77.4	4.1	81.5	3.3		
30.0	67.7	6.3	71.0	5.2	75.6	4.0	79.5	3.2		
32.0	65.8	5.9	69.2	4.9	73.8	3.8	77.5	3.1	80.3	2.7
34.0	64.0	5.6	67.3	4.6	71.8	3.6	75.4	3.0	78.0	2.6
36.0	62.1	5.3	65.4	4.4	69.8	3.5	73.4	2.9	75.6	2.6
38.0	60.2	4.9	63.4	4.2	67.8	3.4	71.1	2.9	73.1	2.6
40.0	57.9	3.8	61.5	4.0	65.7	3.3	68.8	2.8	70.6	2.5
42.0	55.6	2.9	59.4	3.8	63.5	3.1	66.4	2.7	67.9	2.5
44.0	53.3	2.0	57.0	3.0	61.2	3.0	64.1	2.7	65.1	2.5
46.0	50.9	1.3	54.6	2.2	58.8	2.9	61.5	2.6		
48.0			52.0	1.4	56.3	2.4	58.7	2.6		
50.0					53.5	1.6	55.6	2.2		
52.0							52.3	1.3		
54.0										
56.0										
58.0										
60.0										
62.0										
危険角度 (°)	48		48		49		49		60	
フック種類	12t		12t		12t		12t		12t	
フック質量 (t)	0.42		0.42		0.42		0.42		0.42	
巻掛本数	1		1		1		1		1	

SC 性能

45.5m ブーム +1.5m+27.3mSL

ブーム オフセット 作業半径 (m)	45.5m ブーム 27.3mSL(5°)		45.5m ブーム 27.3mSL(15°)		45.5m ブーム 27.3mSL(30°)		45.5m ブーム 27.3mSL(45°)		45.5m ブーム 27.3mSL(60°)	
	ブーム角 (°)	荷重 (ton)	ブーム角 (°)	荷重 (ton)	ブーム角 (°)	荷重 (ton)	ブーム角 (°)	荷重 (ton)	ブーム角 (°)	荷重 (ton)
14.0	81.3	7.0								
16.0	80.0	7.0								
18.0	78.6	7.0								
20.0	77.2	7.0	80.7	7.0						
22.0	75.8	7.0	79.3	6.7						
24.0	74.3	7.0	77.7	6.3						
26.0	72.9	7.0	76.2	6.0	80.5	4.4				
28.0	71.4	7.0	74.5	5.6	78.8	4.2				
30.0	69.8	6.6	72.9	5.4	77.2	4.1	80.7	3.3		
32.0	68.2	6.3	71.2	5.1	75.4	3.9	78.9	3.2	81.4	2.7
34.0	66.5	5.9	69.5	4.8	73.6	3.7	77.1	3.1	79.4	2.7
36.0	64.9	5.6	67.8	4.6	71.9	3.6	75.1	3.0	77.3	2.6
38.0	62.9	4.6	66.1	4.4	70.1	3.5	73.2	2.9	75.1	2.6
40.0	60.8	3.5	64.3	4.2	68.2	3.4	71.2	2.8	72.9	2.5
42.0	58.8	2.6	62.4	3.7	66.2	3.2	69.2	2.8	70.6	2.5
44.0	56.7	1.7	60.3	2.8	64.3	3.1	67.0	2.7	68.1	2.5
46.0			58.0	1.9	62.3	3.0	64.8	2.7	65.7	2.5
48.0					59.9	2.3	62.4	2.6		
50.0					57.5	1.5	59.9	2.2		
52.0							57.1	1.4		
54.0										
56.0										
58.0										
60.0										
62.0										
危険角度 (°)	53		54		54		54		60	
フック種類	12t		12t		12t		12t		12t	
フック質量 (t)	0.42		0.42		0.42		0.42		0.42	
巻掛本数	1		1		1		1		1	

SC 性能

50.0m ブーム +1.5m+27.3mSL

ブーム オフセット 作業半径 (m)	50.0m ブーム 27.3mSL(5°)		50.0m ブーム 27.3mSL(15°)		50.0m ブーム 27.3mSL(30°)		50.0m ブーム 27.3mSL(45°)		50.0m ブーム 27.3mSL(60°)	
	ブーム角 (°)	荷重 (ton)	ブーム角 (°)	荷重 (ton)	ブーム角 (°)	荷重 (ton)	ブーム角 (°)	荷重 (ton)	ブーム角 (°)	荷重 (ton)
16.0	80.5	7.0								
18.0	79.2	7.0								
20.0	78.0	7.0	81.3	7.0						
22.0	76.6	7.0	80.0	6.9						
24.0	75.3	7.0	78.5	6.5						
26.0	74.0	7.0	77.0	6.1	81.1	4.5				
28.0	72.7	7.0	75.6	5.8	79.6	4.3				
30.0	71.3	7.0	74.2	5.6	78.0	4.1	81.3	3.3		
32.0	69.8	6.6	72.7	5.3	76.5	4.0	79.7	3.2		
34.0	68.3	6.2	71.0	5.0	74.9	3.8	78.0	3.1	80.2	2.7
36.0	66.6	5.5	69.5	4.8	73.2	3.7	76.3	3.0	78.3	2.6
38.0	64.7	4.3	67.9	4.6	71.6	3.6	74.4	2.9	76.4	2.6
40.0	62.8	3.3	66.2	4.4	69.8	3.4	72.7	2.9	74.4	2.6
42.0	60.8	2.3	64.4	3.5	68.1	3.3	70.8	2.8	72.3	2.5
44.0			62.3	2.6	66.3	3.2	68.9	2.7	70.2	2.5
46.0			60.3	1.7	64.5	3.1	67.0	2.7	68.0	2.5
48.0					62.4	2.2	65.0	2.7	65.6	2.5
50.0							62.7	2.2		
52.0										
54.0										
56.0										
58.0										
60.0										
62.0										
危険角度 (°)	58		58		59		59		60	
フック種類	12t		12t		12t		12t		12t	
フック質量 (t)	0.42		0.42		0.42		0.42		0.42	
巻掛本数	1		1		1		1		1	

SD 性能

40.9m ブーム +1.5m+10.5mSL

ブーム オフセット 作業半径 (m)	40.9m ブーム 10.5mSL(5°)		40.9m ブーム 10.5mSL(15°)		40.9m ブーム 10.5mSL(30°)		40.9m ブーム 10.5mSL(45°)		40.9m ブーム 10.5mSL(60°)	
	ブーム角 (°)	荷重 (ton)	ブーム角 (°)	荷重 (ton)	ブーム角 (°)	荷重 (ton)	ブーム角 (°)	荷重 (ton)	ブーム角 (°)	荷重 (ton)
9.0	80.6	24.0								
10.0	79.5	24.0	81.4	24.0						
11.0	78.5	24.0	80.4	23.3						
12.0	77.5	24.0	79.4	22.4						
14.0	75.5	24.0	77.2	20.9	79.4	16.6	81.2	13.8		
16.0	73.2	20.7	75.0	19.5	77.1	15.9	78.9	13.4	80.0	11.2
18.0	70.7	15.7	72.6	16.9	74.9	15.2	76.5	13.1	77.5	11.0
20.0	68.3	12.1	70.1	13.1	72.6	14.5	74.2	12.7	74.9	10.9
22.0	65.8	9.3	67.6	10.2	69.9	11.3	71.7	12.2	72.3	10.8
24.0	63.2	7.0	65.0	7.9	67.2	8.8	68.8	9.5	69.6	9.9
26.0	60.6	4.7	62.4	5.6	64.6	6.8	66.0	7.4	66.6	7.7
28.0							63.1	5.3		
30.0										
32.0										
34.0										
36.0										
38.0										
40.0										
42.0										
44.0										
46.0										
危険角度 (°)	58		58		59		59		60	
フック種類	24t		24t		24t		24t		24t	
フック質量 (t)	0.88		0.88		0.88		0.88		0.88	
巻掛本数	2		2		2		2		2	

SD 性能

45.5m ブーム +1.5m+10.5mSL

ブーム オフセット 作業半径 (m)	45.5m ブーム 10.5mSL(5°)		45.5m ブーム 10.5mSL(15°)		45.5m ブーム 10.5mSL(30°)		45.5m ブーム 10.5mSL(45°)		45.5m ブーム 10.5mSL(60°)	
	ブーム角 (°)	荷重 (ton)	ブーム角 (°)	荷重 (ton)	ブーム角 (°)	荷重 (ton)	ブーム角 (°)	荷重 (ton)	ブーム角 (°)	荷重 (ton)
10.0	80.7	24.0								
11.0	79.9	24.0								
12.0	78.9	24.0	80.6	23.2						
14.0	77.2	24.0	78.8	21.6	80.7	16.9				
16.0	75.1	20.6	76.8	20.3	78.7	16.2	80.3	13.6	81.3	11.2
18.0	72.9	15.7	74.6	16.9	76.6	15.6	78.3	13.2	79.2	11.1
20.0	70.5	12.1	72.3	13.1	74.5	14.5	76.1	12.9	76.9	10.9
22.0	68.2	9.3	70.0	10.2	72.2	11.3	73.9	12.2	74.6	10.8
24.0	65.9	6.9	67.6	7.8	69.7	8.8	71.4	9.6	72.3	10.0
26.0			65.3	5.6	67.4	6.8	68.9	7.5	69.6	7.8
28.0					64.8	4.6	66.3	5.4	66.9	5.8
30.0										
32.0										
34.0										
36.0										
38.0										
40.0										
42.0										
44.0										
46.0										
危険角度 (°)	62		63		63		63		63	
フック種類	24t		24t		24t		24t		24t	
フック質量 (t)	0.88		0.88		0.88		0.88		0.88	
巻掛本数	2		2		2		2		2	

SD 性能

50.0m ブーム +1.5m+10.5mSL

ブーム オフセット 作業半径 (m)	50.0m ブーム 10.5mSL(5°)		50.0m ブーム 10.5mSL(15°)		50.0m ブーム 10.5mSL(30°)		50.0m ブーム 10.5mSL(45°)		50.0m ブーム 10.5mSL(60°)	
	ブーム角 (°)	荷重 (ton)	ブーム角 (°)	荷重 (ton)	ブーム角 (°)	荷重 (ton)	ブーム角 (°)	荷重 (ton)	ブーム角 (°)	荷重 (ton)
11.0	80.8	20.0								
12.0	80.1	20.0								
14.0	78.5	20.0	80.0	20.0						
16.0	76.8	20.0	78.4	20.0	80.1	16.5	81.5	13.7		
18.0	74.7	15.6	76.4	16.9	78.3	15.9	79.7	13.4	80.4	11.1
20.0	72.6	12.0	74.2	13.0	76.4	14.5	77.7	13.0	78.4	11.0
22.0	70.4	9.1	72.1	10.1	74.2	11.3	75.8	12.3	76.4	10.9
24.0	68.3	6.7	69.9	7.8	72.0	8.8	73.4	9.6	74.3	10.1
26.0			67.7	5.5	69.7	6.8	71.2	7.5	71.8	7.9
28.0							68.7	5.5	69.4	5.9
30.0										
32.0										
34.0										
36.0										
38.0										
40.0										
42.0										
44.0										
46.0										
危険角度 (°)	66		66		66		66		66	
フック種類	24t		24t		24t		24t		24t	
フック質量 (t)	0.88		0.88		0.88		0.88		0.88	
巻掛本数	2		2		2		2		2	

SD 性能

40.9m ブーム +1.5m+18.9mSL

オフセット 作業半径 (m)	40.9m ブーム 18.9mSL(5°)		40.9m ブーム 18.9mSL(15°)		40.9m ブーム 18.9mSL(30°)		40.9m ブーム 18.9mSL(45°)		40.9m ブーム 18.9mSL(60°)	
	ブーム角 (°)	荷重 (ton)	ブーム角 (°)	荷重 (ton)	ブーム角 (°)	荷重 (ton)	ブーム角 (°)	荷重 (ton)	ブーム角 (°)	荷重 (ton)
10.0	81.5	10.0								
11.0	80.6	10.0								
12.0	79.8	10.0								
14.0	78.0	10.0	81.0	10.0						
16.0	76.2	10.0	79.2	10.0						
18.0	74.4	10.0	77.3	10.0	81.1	8.1				
20.0	72.5	10.0	75.5	10.0	79.2	7.7				
22.0	70.7	10.0	73.6	9.7	77.1	7.3	80.2	6.0		
24.0	68.8	9.5	71.5	9.1	75.1	7.0	78.0	5.8	80.1	5.1
26.0	66.6	7.6	69.5	8.6	73.0	6.8	75.8	5.7	77.6	5.1
28.0	64.4	5.9	67.3	7.1	70.8	6.5	73.6	5.5	75.2	5.0
30.0	62.0	4.2	65.0	5.5	68.6	6.3	71.2	5.4	72.7	4.9
32.0	59.7	2.7	62.5	3.9	66.3	5.5	68.8	5.3	70.1	4.9
34.0					63.7	4.0	66.3	5.1	67.3	4.9
36.0					61.1	2.6	63.5	3.6	64.4	4.0
38.0							60.6	2.2		
40.0										
42.0										
44.0										
46.0										
48.0										
50.0										
52.0										
54.0										
56.0										
危険角度 (°)	58		59		59		59		60	
フック種類	12t		12t		12t		12t		12t	
フック質量 (t)	0.42		0.42		0.42		0.42		0.42	
巻掛本数	1		1		1		1		1	

SD 性能

45.5m ブーム +1.5m+18.9mSL

オフセット 作業半径 (m)	45.5m ブーム 18.9mSL(5°)		45.5m ブーム 18.9mSL(15°)		45.5m ブーム 18.9mSL(30°)		45.5m ブーム 18.9mSL(45°)		45.5m ブーム 18.9mSL(60°)	
	ブーム角 (°)	荷重 (ton)	ブーム角 (°)	荷重 (ton)	ブーム角 (°)	荷重 (ton)	ブーム角 (°)	荷重 (ton)	ブーム角 (°)	荷重 (ton)
11.0	81.4	10.0								
12.0	80.6	10.0								
14.0	79.0	10.0								
16.0	77.4	10.0	80.3	10.0						
18.0	75.8	10.0	78.5	10.0						
20.0	74.2	10.0	76.9	10.0	80.3	7.8				
22.0	72.5	10.0	75.2	10.0	78.5	7.5	81.3	6.1		
24.0	70.8	9.3	73.4	9.5	76.6	7.2	79.3	5.9	81.2	5.2
26.0	68.7	7.4	71.5	8.6	74.7	6.9	77.3	5.7	79.1	5.1
28.0	66.6	5.7	69.4	6.9	72.8	6.7	75.2	5.6	76.9	5.0
30.0	64.5	4.0	67.4	5.4	70.9	6.5	73.2	5.5	74.6	5.0
32.0			65.1	3.8	68.7	5.5	71.1	5.4	72.4	4.9
34.0					66.4	3.9	68.9	5.1	70.0	4.9
36.0							66.4	3.6	67.4	4.1
38.0									64.6	2.6
40.0										
42.0										
44.0										
46.0										
48.0										
50.0										
52.0										
54.0										
56.0										
危険角度 (°)	62		63		63		63		63	
フック種類	12t		12t		12t		12t		12t	
フック質量 (t)	0.42		0.42		0.42		0.42		0.42	
巻掛本数	1		1		1		1		1	

SD 性能

50.0m ブーム +1.5m+18.9mSL

オフセット 作業半径 (m)	50.0m ブーム 18.9mSL(5°)		50.0m ブーム 18.9mSL(15°)		50.0m ブーム 18.9mSL(30°)		50.0m ブーム 18.9mSL(45°)		50.0m ブーム 18.9mSL(60°)	
	ブーム角 (°)	荷重 (ton)	ブーム角 (°)	荷重 (ton)	ブーム角 (°)	荷重 (ton)	ブーム角 (°)	荷重 (ton)	ブーム角 (°)	荷重 (ton)
12.0	81.5	10.0								
14.0	80.0	10.0								
16.0	78.6	10.0	81.2	10.0						
18.0	77.2	10.0	79.7	10.0						
20.0	75.6	10.0	78.2	10.0	81.3	8.0				
22.0	74.2	10.0	76.7	10.0	79.7	7.6				
24.0	72.6	9.2	75.2	9.9	78.0	7.4	80.4	6.0		
26.0	70.6	7.2	73.3	8.5	76.3	7.1	78.6	5.8	80.3	5.1
28.0	68.7	5.5	71.4	6.8	74.6	6.8	76.9	5.7	78.3	5.0
30.0			69.4	5.2	72.8	6.6	75.0	5.5	76.3	5.0
32.0					70.8	5.4	73.1	5.4	74.4	4.9
34.0							71.1	5.1	72.3	4.9
36.0							68.8	3.6	70.0	4.2
38.0										
40.0										
42.0										
44.0										
46.0										
48.0										
50.0										
52.0										
54.0										
56.0										
危険角度 (°)	66		66		66		66		66	
フック種類	12t		12t		12t		12t		12t	
フック質量 (t)	0.42		0.42		0.42		0.42		0.42	
巻掛本数	1		1		1		1		1	

SD 性能

40.9m ブーム +1.5m+27.3mSL

オフセット 作業半径 (m)	40.9m ブーム 27.3mSL(5°)		40.9m ブーム 27.3mSL(15°)		40.9m ブーム 27.3mSL(30°)		40.9m ブーム 27.3mSL(45°)		40.9m ブーム 27.3mSL(60°)	
	ブーム角 (°)	荷重 (ton)	ブーム角 (°)	荷重 (ton)	ブーム角 (°)	荷重 (ton)	ブーム角 (°)	荷重 (ton)	ブーム角 (°)	荷重 (ton)
14.0	80.4	7.0								
16.0	78.9	7.0								
18.0	77.4	7.0	81.3	7.0						
20.0	75.9	7.0	79.7	6.9						
22.0	74.3	7.0	78.0	6.5						
24.0	72.7	7.0	76.3	6.1	81.2	4.6				
26.0	71.1	7.0	74.6	5.8	79.3	4.3				
28.0	69.4	6.7	72.8	5.4	77.4	4.1	81.5	3.3		
30.0	67.7	6.2	71.0	5.2	75.6	4.0	79.5	3.2		
32.0	65.5	4.8	69.2	4.9	73.8	3.8	77.5	3.1	80.3	2.7
34.0	63.4	3.5	67.3	4.6	71.8	3.6	75.4	3.0	78.0	2.6
36.0			65.2	3.8	69.8	3.5	73.4	2.9	75.6	2.6
38.0			62.9	2.6	67.8	3.4	71.1	2.9	73.1	2.6
40.0					65.7	3.3	68.8	2.8	70.6	2.5
42.0					63.2	2.2	66.4	2.7	67.9	2.5
44.0							64.0	2.3	65.1	2.5
46.0										
48.0										
50.0										
52.0										
54.0										
56.0										
58.0										
60.0										
62.0										
危険角度 (°)	60		60		61		61		61	
フック種類	12t		12t		12t		12t		12t	
フック質量 (t)	0.42		0.42		0.42		0.42		0.42	
巻掛本数	1		1		1		1		1	

SD 性能

45.5m ブーム +1.5m+27.3mSL

オフセット 作業半径 (m)	45.5m ブーム 27.3mSL(5°)		45.5m ブーム 27.3mSL(15°)		45.5m ブーム 27.3mSL(30°)		45.5m ブーム 27.3mSL(45°)		45.5m ブーム 27.3mSL(60°)	
	ブーム角 (°)	荷重 (ton)	ブーム角 (°)	荷重 (ton)	ブーム角 (°)	荷重 (ton)	ブーム角 (°)	荷重 (ton)	ブーム角 (°)	荷重 (ton)
14.0	81.3	7.0								
16.0	80.0	7.0								
18.0	78.6	7.0								
20.0	77.2	7.0	80.7	7.0						
22.0	75.8	7.0	79.3	6.7						
24.0	74.3	7.0	77.7	6.3						
26.0	72.9	7.0	76.2	6.0	80.5	4.4				
28.0	71.4	7.0	74.5	5.6	78.8	4.2				
30.0	69.6	5.9	72.9	5.4	77.2	4.1	80.7	3.3		
32.0	67.7	4.5	71.2	5.1	75.4	3.9	78.9	3.2	81.4	2.7
34.0			69.5	4.8	73.6	3.7	77.1	3.1	79.4	2.7
36.0			67.5	3.5	71.9	3.6	75.1	3.0	77.3	2.6
38.0					70.1	3.5	73.2	2.9	75.1	2.6
40.0					68.1	3.1	71.2	2.8	72.9	2.5
42.0							69.2	2.8	70.6	2.5
44.0									68.1	2.5
46.0										
48.0										
50.0										
52.0										
54.0										
56.0										
58.0										
60.0										
62.0										
危険角度 (°)	63		64		65		65		65	
フック種類	12t		12t		12t		12t		12t	
フック質量 (t)	0.42		0.42		0.42		0.42		0.42	
巻掛本数	1		1		1		1		1	

SD 性能

50.0m ブーム +1.5m+27.3mSL

オフセット 作業半径 (m)	50.0m ブーム 27.3mSL(5°)		50.0m ブーム 27.3mSL(15°)		50.0m ブーム 27.3mSL(30°)		50.0m ブーム 27.3mSL(45°)		50.0m ブーム 27.3mSL(60°)	
	ブーム角 (°)	荷重 (ton)	ブーム角 (°)	荷重 (ton)	ブーム角 (°)	荷重 (ton)	ブーム角 (°)	荷重 (ton)	ブーム角 (°)	荷重 (ton)
16.0	80.5	7.0								
18.0	79.2	7.0								
20.0	78.0	7.0	81.3	7.0						
22.0	76.6	7.0	80.0	6.9						
24.0	75.3	7.0	78.5	6.5						
26.0	74.0	7.0	77.0	6.1	81.1	4.5				
28.0	72.7	7.0	75.6	5.8	79.6	4.3				
30.0	70.9	5.6	74.2	5.6	78.0	4.1	81.3	3.3		
32.0			72.7	5.3	76.5	4.0	79.7	3.2		
34.0			70.9	4.6	74.9	3.8	78.0	3.1	80.2	2.7
36.0					73.2	3.7	76.3	3.0	78.3	2.6
38.0					71.6	3.6	74.4	2.9	76.4	2.6
40.0							72.7	2.9	74.4	2.6
42.0							70.8	2.8	72.3	2.5
44.0									70.2	2.5
46.0										
48.0										
50.0										
52.0										
54.0										
56.0										
58.0										
60.0										
62.0										
危険角度 (°)	66		67		68		68		68	
フック種類	12t		12t		12t		12t		12t	
フック質量 (t)	0.42		0.42		0.42		0.42		0.42	
巻掛本数	1		1		1		1		1	

SE 性能

40.9m ブーム +1.5m+27.3mSL

オフセット 作業半径 (m)	40.9m ブーム 27.3mSL(5°)		40.9m ブーム 27.3mSL(15°)		40.9m ブーム 27.3mSL(30°)		40.9m ブーム 27.3mSL(45°)		40.9m ブーム 27.3mSL(60°)	
	ブーム角 (°)	荷重 (ton)	ブーム角 (°)	荷重 (ton)	ブーム角 (°)	荷重 (ton)	ブーム角 (°)	荷重 (ton)	ブーム角 (°)	荷重 (ton)
14.0	80.4	7.0								
16.0	78.9	7.0								
18.0	77.4	7.0	81.3	7.0						
20.0	75.9	7.0	79.7	6.9						
22.0	74.3	7.0	78.0	6.5						
24.0	72.7	7.0	76.3	6.1	81.2	4.6				
26.0	70.8	5.8	74.6	5.8	79.3	4.3				
28.0	68.9	4.6	72.8	5.4	77.4	4.1	81.5	3.3		
30.0			70.9	4.7	75.6	4.0	79.5	3.2		
32.0			68.8	3.6	73.8	3.8	77.5	3.1	80.3	2.7
34.0					71.8	3.6	75.4	3.0	78.0	2.6
36.0					69.7	3.2	73.4	2.9	75.6	2.6
38.0							71.1	2.9	73.1	2.6
40.0										
42.0										
44.0										
46.0										
48.0										
50.0										
52.0										
54.0										
56.0										
58.0										
60.0										
62.0										
危険角度 (°)	66		67		67		68		68	
フック種類	12t		12t		12t		12t		12t	
フック質量 (t)	0.42		0.42		0.42		0.42		0.42	
巻掛本数	1		1		1		1		1	

SE 性能

45.5m ブーム +1.5m+27.3mSL

オフセット 作業半径 (m)	45.5m ブーム 27.3mSL(5°)		45.5m ブーム 27.3mSL(15°)		45.5m ブーム 27.3mSL(30°)		45.5m ブーム 27.3mSL(45°)		45.5m ブーム 27.3mSL(60°)	
	ブーム角 (°)	荷重 (ton)	ブーム角 (°)	荷重 (ton)	ブーム角 (°)	荷重 (ton)	ブーム角 (°)	荷重 (ton)	ブーム角 (°)	荷重 (ton)
14.0	81.3	7.0								
16.0	80.0	7.0								
18.0	78.6	7.0								
20.0	77.2	7.0	80.7	7.0						
22.0	75.8	7.0	79.3	6.7						
24.0	74.3	7.0	77.7	6.3						
26.0	72.6	5.6	76.2	6.0	80.5	4.4				
28.0			74.5	5.6	78.8	4.2				
30.0			72.6	4.5	77.2	4.1	80.7	3.3		
32.0					75.4	3.9	78.9	3.2	81.4	2.7
34.0					73.6	3.7	77.1	3.1	79.4	2.7
36.0							75.1	3.0	77.3	2.6
38.0							73.2	2.9	75.1	2.6
40.0										
42.0										
44.0										
46.0										
48.0										
50.0										
52.0										
54.0										
56.0										
58.0										
60.0										
62.0										
危険角度 (°)	69		70		70		71		71	
フック種類	12t		12t		12t		12t		12t	
フック質量 (t)	0.42		0.42		0.42		0.42		0.42	
巻掛本数	1		1		1		1		1	

SE 性能

50.0m ブーム +1.5m+27.3mSL

オフセット 作業半径 (m)	50.0m ブーム 27.3mSL(5°)		50.0m ブーム 27.3mSL(15°)		50.0m ブーム 27.3mSL(30°)		50.0m ブーム 27.3mSL(45°)		50.0m ブーム 27.3mSL(60°)	
	ブーム角 (°)	荷重 (ton)	ブーム角 (°)	荷重 (ton)	ブーム角 (°)	荷重 (ton)	ブーム角 (°)	荷重 (ton)	ブーム角 (°)	荷重 (ton)
16.0	80.5	7.0								
18.0	79.2	7.0								
20.0	78.0	7.0	81.3	7.0						
22.0	76.6	7.0	80.0	6.9						
24.0	75.3	6.8	78.5	6.5						
26.0			77.0	6.1	81.1	4.5				
28.0			75.6	5.6	79.6	4.3				
30.0					78.0	4.1	81.3	3.3		
32.0					76.5	4.0	79.7	3.2		
34.0							78.0	3.1	80.2	2.7
36.0							76.3	3.0	78.3	2.6
38.0									76.4	2.6
40.0										
42.0										
44.0										
46.0										
48.0										
50.0										
52.0										
54.0										
56.0										
58.0										
60.0										
62.0										
危険角度 (°)	72		72		73		73		73	
フック種類	12t		12t		12t		12t		12t	
フック質量 (t)	0.42		0.42		0.42		0.42		0.42	
巻掛本数	1		1		1		1		1	

SE 性能

40.9m ブーム +1.5m+10.5mSL

ブーム オフセット 作業半径 (m)	40.9m ブーム 10.5mSL(5°)		40.9m ブーム 10.5mSL(15°)		40.9m ブーム 10.5mSL(30°)		40.9m ブーム 10.5mSL(45°)		40.9m ブーム 10.5mSL(60°)	
	ブーム角 (°)	荷重 (ton)	ブーム角 (°)	荷重 (ton)	ブーム角 (°)	荷重 (ton)	ブーム角 (°)	荷重 (ton)	ブーム角 (°)	荷重 (ton)
9.0	80.6	24.0								
10.0	79.5	24.0	81.4	24.0						
11.0	78.5	24.0	80.4	23.3						
12.0	77.5	24.0	79.4	22.4						
14.0	75.2	19.8	77.2	20.9	79.4	16.6	81.2	13.8		
16.0	72.8	14.3	74.7	15.6	77.1	15.9	78.9	13.4	80.0	11.2
18.0	70.3	10.4	72.2	11.6	74.7	13.1	76.5	13.1	77.5	11.0
20.0	68.0	7.6	69.7	8.5	72.2	9.8	74.0	10.8	74.9	10.9
22.0			67.2	6.2	69.6	7.3	71.3	8.1	72.2	8.6
24.0					66.9	5.3	68.5	6.0	69.3	6.3
26.0										
28.0										
30.0										
32.0										
34.0										
36.0										
38.0										
40.0										
42.0										
44.0										
46.0										
危険角度 (°)	65		65		66		66		66	
フック種類	24t		24t		24t		24t		24t	
フック質量 (t)	0.88		0.88		0.88		0.88		0.88	
巻掛本数	2		2		2		2		2	

SE 性能

45.5m ブーム +1.5m+10.5mSL

ブーム オフセット 作業半径 (m)	45.5m ブーム 10.5mSL(5°)		45.5m ブーム 10.5mSL(15°)		45.5m ブーム 10.5mSL(30°)		45.5m ブーム 10.5mSL(45°)		45.5m ブーム 10.5mSL(60°)	
	ブーム角 (°)	荷重 (ton)	ブーム角 (°)	荷重 (ton)	ブーム角 (°)	荷重 (ton)	ブーム角 (°)	荷重 (ton)	ブーム角 (°)	荷重 (ton)
10.0	80.7	24.0								
11.0	79.9	24.0								
12.0	78.9	24.0	80.6	23.2						
14.0	76.9	19.7	78.8	21.4	80.7	16.9				
16.0	74.6	14.2	76.4	15.6	78.7	16.2	80.3	13.6	81.3	11.2
18.0	72.4	10.4	74.1	11.5	76.4	13.1	78.3	13.2	79.2	11.1
20.0			71.9	8.5	74.0	9.8	75.9	10.8	76.9	10.9
22.0					71.7	7.3	73.5	8.1	74.4	8.7
24.0									71.9	6.4
26.0										
28.0										
30.0										
32.0										
34.0										
36.0										
38.0										
40.0										
42.0										
44.0										
46.0										
危険角度 (°)	68		69		69		69		69	
フック種類	24t		24t		24t		24t		24t	
フック質量 (t)	0.88		0.88		0.88		0.88		0.88	
巻掛本数	2		2		2		2		2	

SE 性能

50.0m ブーム +1.5m+10.5mSL

ブーム オフセット 作業半径 (m)	50.0m ブーム 10.5mSL(5°)		50.0m ブーム 10.5mSL(15°)		50.0m ブーム 10.5mSL(30°)		50.0m ブーム 10.5mSL(45°)		50.0m ブーム 10.5mSL(60°)	
	ブーム角 (°)	荷重 (ton)	ブーム角 (°)	荷重 (ton)	ブーム角 (°)	荷重 (ton)	ブーム角 (°)	荷重 (ton)	ブーム角 (°)	荷重 (ton)
11.0	80.8	20.0								
12.0	80.1	20.0								
14.0	78.4	19.0	80.0	20.0						
16.0	76.2	13.9	78.0	15.6	80.1	16.5	81.5	13.7		
18.0	74.1	10.1	75.9	11.5	78.0	13.0	79.7	13.4	80.4	11.1
20.0			73.7	8.3	75.8	9.8	77.5	10.8	78.4	11.0
22.0					73.7	7.3	75.2	8.2	76.1	8.7
24.0									73.8	6.5
26.0										
28.0										
30.0										
32.0										
34.0										
36.0										
38.0										
40.0										
42.0										
44.0										
46.0										
危険角度 (°)	71		71		71		72		72	
フック種類	24t		24t		24t		24t		24t	
フック質量 (t)	0.88		0.88		0.88		0.88		0.88	
巻掛本数	2		2		2		2		2	

SE 性能

40.9m ブーム +1.5m+18.9mSL

オフセット 作業半径 (m)	40.9m ブーム 18.9mSL(5°)		40.9m ブーム 18.9mSL(15°)		40.9m ブーム 18.9mSL(30°)		40.9m ブーム 18.9mSL(45°)		40.9m ブーム 18.9mSL(60°)	
	ブーム角 (°)	荷重 (ton)	ブーム角 (°)	荷重 (ton)	ブーム角 (°)	荷重 (ton)	ブーム角 (°)	荷重 (ton)	ブーム角 (°)	荷重 (ton)
10.0	81.5	10.0								
11.0	80.6	10.0								
12.0	79.8	10.0								
14.0	78.0	10.0	81.0	10.0						
16.0	76.2	10.0	79.2	10.0						
18.0	74.4	10.0	77.3	10.0	81.1	8.1				
20.0	72.5	10.0	75.5	10.0	79.2	7.7				
22.0	70.4	7.7	73.5	9.1	77.1	7.3	80.2	6.0		
24.0	68.3	5.9	71.3	7.1	75.1	7.0	78.0	5.8	80.1	5.1
26.0			69.1	5.5	73.0	6.8	75.8	5.7	77.6	5.1
28.0					70.7	5.5	73.6	5.5	75.2	5.0
30.0							71.2	5.1	72.7	4.9
32.0									70.0	4.4
34.0										
36.0										
38.0										
40.0										
42.0										
44.0										
46.0										
48.0										
50.0										
52.0										
54.0										
56.0										
危険角度 (°)	65		65		66		66		66	
フック種類	12t		12t		12t		12t		12t	
フック質量 (t)	0.42		0.42		0.42		0.42		0.42	
巻掛本数	1		1		1		1		1	

SE 性能

45.5m ブーム +1.5m+18.9mSL

オフセット 作業半径 (m)	45.5m ブーム 18.9mSL(5°)		45.5m ブーム 18.9mSL(15°)		45.5m ブーム 18.9mSL(30°)		45.5m ブーム 18.9mSL(45°)		45.5m ブーム 18.9mSL(60°)	
	ブーム角 (°)	荷重 (ton)	ブーム角 (°)	荷重 (ton)	ブーム角 (°)	荷重 (ton)	ブーム角 (°)	荷重 (ton)	ブーム角 (°)	荷重 (ton)
11.0	81.4	10.0								
12.0	80.6	10.0								
14.0	79.0	10.0								
16.0	77.4	10.0	80.3	10.0						
18.0	75.8	10.0	78.5	10.0						
20.0	74.2	9.9	76.9	10.0	80.3	7.8				
22.0			75.1	9.0	78.5	7.5	81.3	6.1		
24.0			73.0	7.0	76.6	7.2	79.3	5.9	81.2	5.2
26.0					74.7	6.9	77.3	5.7	79.1	5.1
28.0					72.5	5.4	75.2	5.6	76.9	5.0
30.0							73.2	5.1	74.6	5.0
32.0										
34.0										
36.0										
38.0										
40.0										
42.0										
44.0										
46.0										
48.0										
50.0										
52.0										
54.0										
56.0										
危険角度 (°)	68		69		69		69		69	
フック種類	12t		12t		12t		12t		12t	
フック質量 (t)	0.42		0.42		0.42		0.42		0.42	
巻掛本数	1		1		1		1		1	

SE 性能

50.0m ブーム +1.5m+18.9mSL

オフセット 作業半径 (m)	50.0m ブーム 18.9mSL(5°)		50.0m ブーム 18.9mSL(15°)		50.0m ブーム 18.9mSL(30°)		50.0m ブーム 18.9mSL(45°)		50.0m ブーム 18.9mSL(60°)	
	ブーム角 (°)	荷重 (ton)	ブーム角 (°)	荷重 (ton)	ブーム角 (°)	荷重 (ton)	ブーム角 (°)	荷重 (ton)	ブーム角 (°)	荷重 (ton)
12.0	81.5	10.0								
14.0	80.0	10.0								
16.0	78.6	10.0	81.2	10.0						
18.0	77.2	10.0	79.7	10.0						
20.0	75.6	9.7	78.2	10.0	81.3	8.0				
22.0	73.7	7.2	76.5	8.9	79.7	7.6				
24.0					78.0	7.4	80.4	6.0		
26.0					76.3	6.9	78.6	5.8	80.3	5.1
28.0							76.9	5.7	78.3	5.0
30.0									76.3	5.0
32.0										
34.0										
36.0										
38.0										
40.0										
42.0										
44.0										
46.0										
48.0										
50.0										
52.0										
54.0										
56.0										
危険角度 (°)	71		71		71		72		72	
フック種類	12t		12t		12t		12t		12t	
フック質量 (t)	0.42		0.42		0.42		0.42		0.42	
巻掛本数	1		1		1		1		1	

SE 性能

40.9m ブーム +1.5m+27.3mSL

ブーム オフセット 作業半径 (m)	40.9m ブーム 27.3mSL(5°)		40.9m ブーム 27.3mSL(15°)		40.9m ブーム 27.3mSL(30°)		40.9m ブーム 27.3mSL(45°)		40.9m ブーム 27.3mSL(60°)	
	ブーム角 (°)	荷重 (ton)	ブーム角 (°)	荷重 (ton)	ブーム角 (°)	荷重 (ton)	ブーム角 (°)	荷重 (ton)	ブーム角 (°)	荷重 (ton)
14.0	80.4	7.0								
16.0	78.9	7.0								
18.0	77.4	7.0	81.3	7.0						
20.0	75.9	7.0	79.7	6.9						
22.0	74.3	7.0	78.0	6.5						
24.0	72.7	7.0	76.3	6.1	81.2	4.6				
26.0	70.8	5.8	74.6	5.8	79.3	4.3				
28.0	68.9	4.6	72.8	5.4	77.4	4.1	81.5	3.3		
30.0			70.9	4.7	75.6	4.0	79.5	3.2		
32.0			68.8	3.6	73.8	3.8	77.5	3.1	80.3	2.7
34.0					71.8	3.6	75.4	3.0	78.0	2.6
36.0					69.7	3.2	73.4	2.9	75.6	2.6
38.0							71.1	2.9	73.1	2.6
40.0										
42.0										
44.0										
46.0										
48.0										
50.0										
52.0										
54.0										
56.0										
58.0										
60.0										
62.0										
危険角度 (°)	66		67		67		68		68	
フック種類	12t		12t		12t		12t		12t	
フック質量 (t)	0.42		0.42		0.42		0.42		0.42	
巻掛本数	1		1		1		1		1	

SE 性能

45.5m ブーム +1.5m+27.3mSL

ブーム オフセット 作業半径 (m)	45.5m ブーム 27.3mSL(5°)		45.5m ブーム 27.3mSL(15°)		45.5m ブーム 27.3mSL(30°)		45.5m ブーム 27.3mSL(45°)		45.5m ブーム 27.3mSL(60°)	
	ブーム角 (°)	荷重 (ton)	ブーム角 (°)	荷重 (ton)	ブーム角 (°)	荷重 (ton)	ブーム角 (°)	荷重 (ton)	ブーム角 (°)	荷重 (ton)
14.0	81.3	7.0								
16.0	80.0	7.0								
18.0	78.6	7.0								
20.0	77.2	7.0	80.7	7.0						
22.0	75.8	7.0	79.3	6.7						
24.0	74.3	7.0	77.7	6.3						
26.0	72.6	5.6	76.2	6.0	80.5	4.4				
28.0			74.5	5.6	78.8	4.2				
30.0			72.6	4.5	77.2	4.1	80.7	3.3		
32.0					75.4	3.9	78.9	3.2	81.4	2.7
34.0					73.6	3.7	77.1	3.1	79.4	2.7
36.0							75.1	3.0	77.3	2.6
38.0							73.2	2.9	75.1	2.6
40.0										
42.0										
44.0										
46.0										
48.0										
50.0										
52.0										
54.0										
56.0										
58.0										
60.0										
62.0										
危険角度 (°)	69		70		70		71		71	
フック種類	12t		12t		12t		12t		12t	
フック質量 (t)	0.42		0.42		0.42		0.42		0.42	
巻掛本数	1		1		1		1		1	

SE 性能

50.0m ブーム +1.5m+27.3mSL

ブーム オフセット 作業半径 (m)	50.0m ブーム 27.3mSL(5°)		50.0m ブーム 27.3mSL(15°)		50.0m ブーム 27.3mSL(30°)		50.0m ブーム 27.3mSL(45°)		50.0m ブーム 27.3mSL(60°)	
	ブーム角 (°)	荷重 (ton)	ブーム角 (°)	荷重 (ton)	ブーム角 (°)	荷重 (ton)	ブーム角 (°)	荷重 (ton)	ブーム角 (°)	荷重 (ton)
16.0	80.5	7.0								
18.0	79.2	7.0								
20.0	78.0	7.0	81.3	7.0						
22.0	76.6	7.0	80.0	6.9						
24.0	75.3	6.8	78.5	6.5						
26.0			77.0	6.1	81.1	4.5				
28.0			75.6	5.6	79.6	4.3				
30.0					78.0	4.1	81.3	3.3		
32.0					76.5	4.0	79.7	3.2		
34.0							78.0	3.1	80.2	2.7
36.0							76.3	3.0	78.3	2.6
38.0									76.4	2.6
40.0										
42.0										
44.0										
46.0										
48.0										
50.0										
52.0										
54.0										
56.0										
58.0										
60.0										
62.0										
危険角度 (°)	72		72		73		73		73	
フック種類	12t		12t		12t		12t		12t	
フック質量 (t)	0.42		0.42		0.42		0.42		0.42	
巻掛本数	1		1		1		1		1	



10.5m スーパーラフィングジブ定格総荷重表

SS 性能

40.9m ブーム +1.5m+10.5mSL

ブーム オフセット 作業半径 (m)	40.9m ブーム 10.5mSL(5°)		40.9m ブーム 10.5mSL(15°)		40.9m ブーム 10.5mSL(30°)		40.9m ブーム 10.5mSL(45°)		40.9m ブーム 10.5mSL(60°)	
	ブーム角 (°)	荷重 (ton)	ブーム角 (°)	荷重 (ton)	ブーム角 (°)	荷重 (ton)	ブーム角 (°)	荷重 (ton)	ブーム角 (°)	荷重 (ton)
9.0	80.6	24.0								
10.0	79.5	24.0	81.4	24.0						
11.0	78.5	24.0	80.4	23.3						
12.0	77.5	24.0	79.4	22.4						
14.0	75.5	24.0	77.2	20.9	79.4	16.6	81.2	13.8		
16.0	73.4	23.9	75.0	19.5	77.1	15.9	78.9	13.4	80.0	11.2
18.0	71.2	22.0	72.7	18.3	74.9	15.2	76.5	13.1	77.5	11.0
20.0	69.0	20.3	70.4	17.2	72.6	14.6	74.2	12.7	74.9	10.9
22.0	66.7	18.9	68.1	16.2	70.2	14.1	71.7	12.4	72.3	10.8
24.0	64.3	17.6	65.7	15.4	67.7	13.6	69.1	12.2	69.7	10.7
26.0	61.8	16.5	63.3	14.6	65.2	13.1	66.5	12.0	66.9	10.7
28.0	59.3	15.5	60.8	13.9	62.6	12.7	63.8	11.8	64.0	10.7
30.0	56.6	14.2	58.2	13.3	59.9	12.4	61.0	11.6		
32.0	53.8	12.2	55.5	12.7	57.1	12.1	58.0	11.5		
34.0	50.8	10.4	52.4	10.9	54.2	11.5	54.9	11.4		
36.0	47.7	8.8	49.2	9.3	50.9	9.7	51.5	10.0		
38.0	44.4	7.4	45.9	7.8	47.4	8.2				
40.0	40.9	6.2	42.4	6.5	43.6	6.8				
42.0	37.1	5.0	38.5	5.3	39.5	5.5				
44.0	32.8	4.0	34.1	4.2	34.8	4.4				
46.0										
危険角度 (°)	22		22		30		45		60	
フック種類	24t		24t		24t		24t		24t	
フック質量 (t)	0.88		0.88		0.88		0.88		0.88	
巻掛本数	2		2		2		2		2	

SS 性能

45.5m ブーム +1.5m+10.5mSL

ブーム オフセット 作業半径 (m)	45.5m ブーム 10.5mSL(5°)		45.5m ブーム 10.5mSL(15°)		45.5m ブーム 10.5mSL(30°)		45.5m ブーム 10.5mSL(45°)		45.5m ブーム 10.5mSL(60°)	
	ブーム角 (°)	荷重 (ton)	ブーム角 (°)	荷重 (ton)	ブーム角 (°)	荷重 (ton)	ブーム角 (°)	荷重 (ton)	ブーム角 (°)	荷重 (ton)
10.0	80.7	24.0								
11.0	79.9	24.0								
12.0	78.9	24.0	80.6	23.2						
14.0	77.2	24.0	78.8	21.6	80.7	16.9				
16.0	75.4	24.0	76.8	20.3	78.7	16.2	80.3	13.6	81.3	11.2
18.0	73.5	23.4	74.8	19.0	76.6	15.6	78.3	13.2	79.2	11.1
20.0	71.5	21.6	72.8	18.0	74.6	15.0	76.1	12.9	76.9	10.9
22.0	69.4	20.2	70.7	17.0	72.5	14.4	74.0	12.6	74.6	10.8
24.0	67.3	18.8	68.6	16.1	70.4	14.0	71.7	12.4	72.4	10.8
26.0	65.2	17.7	66.5	15.4	68.2	13.5	69.5	12.1	69.9	10.7
28.0	62.9	16.1	64.2	14.7	65.9	13.1	67.1	11.9	67.5	10.7
30.0	60.5	14.1	61.9	14.0	63.6	12.7	64.8	11.8	64.9	10.7
32.0	57.9	12.1	59.5	12.7	61.2	12.3	62.3	11.6		
34.0	55.3	10.3	56.8	10.9	58.6	11.3	59.7	11.1		
36.0	52.6	8.7	54.1	9.2	55.8	9.8	56.8	10.1		
38.0	49.8	7.3	51.3	7.8	52.8	8.3	53.7	8.5		
40.0	46.8	6.1	48.4	6.5	49.7	6.9	50.4	7.0		
42.0	43.7	4.9	45.2	5.3	46.5	5.6				
44.0	40.5	3.9	41.8	4.2	42.9	4.5				
46.0					39.1	3.4				
危険角度 (°)	33		33		33		45		60	
フック種類	24t		24t		24t		24t		24t	
フック質量 (t)	0.88		0.88		0.88		0.88		0.88	
巻掛本数	2		2		2		2		2	

SS 性能

50.0m ブーム +1.5m+10.5mSL

ブーム オフセット 作業半径 (m)	50.0m ブーム 10.5mSL(5°)		50.0m ブーム 10.5mSL(15°)		50.0m ブーム 10.5mSL(30°)		50.0m ブーム 10.5mSL(45°)		50.0m ブーム 10.5mSL(60°)	
	ブーム角 (°)	荷重 (ton)	ブーム角 (°)	荷重 (ton)	ブーム角 (°)	荷重 (ton)	ブーム角 (°)	荷重 (ton)	ブーム角 (°)	荷重 (ton)
11.0	80.8	20.0								
12.0	80.1	20.0								
14.0	78.5	20.0	80.0	20.0						
16.0	76.8	20.0	78.4	20.0	80.1	16.5	81.5	13.7		
18.0	75.2	20.0	76.7	19.7	78.3	15.9	79.7	13.4	80.4	11.1
20.0	73.5	20.0	74.9	18.7	76.5	15.3	77.7	13.0	78.4	11.0
22.0	71.8	20.0	73.1	17.7	74.7	14.8	75.8	12.8	76.4	10.9
24.0	69.9	18.4	71.1	16.8	72.7	14.3	73.8	12.5	74.4	10.8
26.0	67.9	16.4	69.2	15.7	70.8	13.9	71.9	12.3	72.2	10.7
28.0	65.8	14.7	67.1	14.2	68.8	13.5	69.8	12.1	70.1	10.7
30.0	63.6	13.3	65.0	12.8	66.6	12.3	67.6	11.9	67.9	10.6
32.0	61.4	11.9	62.8	11.6	64.3	11.2	65.4	11.0		
34.0	59.1	10.2	60.5	10.5	62.0	10.2	63.0	10.1		
36.0	56.7	8.7	58.1	9.2	59.7	9.3	60.5	9.2		
38.0	54.2	7.3	55.6	7.7	57.2	8.3	57.9	8.5		
40.0	51.6	6.0	53.0	6.4	54.5	6.9	55.1	7.2		
42.0	49.0	4.9	50.3	5.2	51.7	5.7	52.2	5.8		
44.0	46.2	3.8	47.5	4.2	48.8	4.5				
46.0					45.6	3.5				
危険角度 (°)	39		40		41		45		60	
フック種類	24t		24t		24t		24t		24t	
フック質量 (t)	0.88		0.88		0.88		0.88		0.88	
巻掛本数	2		2		2		2		2	

SS 性能

40.9m ブーム +1.5m+18.9mSL

オフセット 作業半径 (m)	40.9m ブーム 18.9mSL(5°)		40.9m ブーム 18.9mSL(15°)		40.9m ブーム 18.9mSL(30°)		40.9m ブーム 18.9mSL(45°)		40.9m ブーム 18.9mSL(60°)	
	ブーム角 (°)	荷重 (ton)	ブーム角 (°)	荷重 (ton)	ブーム角 (°)	荷重 (ton)	ブーム角 (°)	荷重 (ton)	ブーム角 (°)	荷重 (ton)
10.0	81.5	10.0								
11.0	80.6	10.0								
12.0	79.8	10.0								
14.0	78.0	10.0	81.0	10.0						
16.0	76.2	10.0	79.2	10.0						
18.0	74.4	10.0	77.3	10.0	81.1	8.1				
20.0	72.5	10.0	75.5	10.0	79.2	7.7				
22.0	70.7	10.0	73.6	9.7	77.1	7.3	80.2	6.0		
24.0	68.9	10.0	71.5	9.1	75.1	7.0	78.0	5.8	80.1	5.1
26.0	66.9	10.0	69.5	8.6	73.0	6.8	75.8	5.7	77.6	5.1
28.0	64.9	9.7	67.5	8.2	70.8	6.5	73.6	5.5	75.2	5.0
30.0	62.8	9.1	65.4	7.8	68.6	6.3	71.2	5.4	72.7	4.9
32.0	60.7	8.6	63.1	7.4	66.4	6.1	68.8	5.3	70.1	4.9
34.0	58.4	8.1	60.9	7.1	64.0	5.9	66.3	5.2	67.3	4.9
36.0	56.1	7.6	58.6	6.8	61.7	5.7	63.7	5.1	64.5	4.8
38.0	53.7	7.2	56.2	6.5	59.1	5.5	61.0	5.0		
40.0	51.3	6.9	53.7	6.2	56.5	5.4	58.2	4.9		
42.0	48.7	6.5	51.1	5.9	53.9	5.3	55.2	4.9		
44.0	46.1	6.2	48.3	5.7	50.9	5.2	51.9	4.9		
46.0	43.1	5.5	45.5	5.5	47.8	5.1	48.4	4.9		
48.0	39.9	4.6	42.2	5.0	44.4	5.0				
50.0	36.4	3.8	38.7	4.2	40.6	4.5				
52.0	32.6	3.0	34.7	3.3	36.2	3.6				
54.0	28.3	2.3	30.2	2.6						
56.0										
危険角度 (°)	25		25		30		45		60	
フック種類	12t		12t		12t		12t		12t	
フック質量 (t)	0.42		0.42		0.42		0.42		0.42	
巻掛本数	1		1		1		1		1	

SS 性能

45.5m ブーム +1.5m+18.9mSL

オフセット 作業半径 (m)	45.5m ブーム 18.9mSL(5°)		45.5m ブーム 18.9mSL(15°)		45.5m ブーム 18.9mSL(30°)		45.5m ブーム 18.9mSL(45°)		45.5m ブーム 18.9mSL(60°)	
	ブーム角 (°)	荷重 (ton)	ブーム角 (°)	荷重 (ton)	ブーム角 (°)	荷重 (ton)	ブーム角 (°)	荷重 (ton)	ブーム角 (°)	荷重 (ton)
11.0	81.4	10.0								
12.0	80.6	10.0								
14.0	79.0	10.0								
16.0	77.4	10.0	80.3	10.0						
18.0	75.8	10.0	78.5	10.0						
20.0	74.2	10.0	76.9	10.0	80.3	7.8				
22.0	72.5	10.0	75.2	10.0	78.5	7.5	81.3	6.1		
24.0	70.9	10.0	73.4	9.5	76.6	7.2	79.3	5.9	81.2	5.2
26.0	69.2	10.0	71.6	9.0	74.7	6.9	77.3	5.7	79.1	5.1
28.0	67.4	10.0	69.7	8.6	72.8	6.7	75.2	5.6	76.9	5.0
30.0	65.5	9.8	67.9	8.1	70.9	6.5	73.2	5.5	74.6	5.0
32.0	63.6	9.2	65.9	7.8	68.8	6.2	71.1	5.4	72.4	4.9
34.0	61.7	8.7	63.9	7.4	66.8	6.1	68.9	5.3	70.0	4.9
36.0	59.6	8.2	61.8	7.1	64.7	5.9	66.7	5.2	67.5	4.8
38.0	57.5	7.8	59.8	6.8	62.5	5.7	64.3	5.1	65.0	4.8
40.0	55.4	7.4	57.6	6.6	60.3	5.6	61.9	5.0		
42.0	53.1	7.0	55.4	6.3	57.9	5.4	59.4	4.9		
44.0	50.7	6.2	53.0	6.0	55.4	5.3	56.7	4.9		
46.0	48.2	5.3	50.6	5.8	52.9	5.2	53.9	4.9		
48.0	45.4	4.4	47.8	4.9	50.1	5.1	50.9	4.8		
50.0	42.5	3.6	44.8	4.0	47.1	4.6				
52.0	39.5	2.8	41.8	3.2	43.8	3.7				
54.0	36.3	2.1	38.4	2.5	40.1	2.8				
56.0					36.0	2.0				
危険角度 (°)	33		33		33		45		60	
フック種類	12t		12t		12t		12t		12t	
フック質量 (t)	0.42		0.42		0.42		0.42		0.42	
巻掛本数	1		1		1		1		1	

SS 性能

50.0m ブーム +1.5m+18.9mSL

オフセット 作業半径 (m)	50.0m ブーム 18.9mSL(5°)		50.0m ブーム 18.9mSL(15°)		50.0m ブーム 18.9mSL(30°)		50.0m ブーム 18.9mSL(45°)		50.0m ブーム 18.9mSL(60°)	
	ブーム角 (°)	荷重 (ton)	ブーム角 (°)	荷重 (ton)	ブーム角 (°)	荷重 (ton)	ブーム角 (°)	荷重 (ton)	ブーム角 (°)	荷重 (ton)
12.0	81.5	10.0								
14.0	80.0	10.0								
16.0	78.6	10.0	81.2	10.0						
18.0	77.2	10.0	79.7	10.0						
20.0	75.6	10.0	78.2	10.0	81.3	8.0				
22.0	74.2	10.0	76.7	10.0	79.7	7.6				
24.0	72.7	10.0	75.2	9.9	78.0	7.4	80.4	6.0		
26.0	71.1	10.0	73.5	9.4	76.3	7.1	78.6	5.8	80.3	5.1
28.0	69.6	10.0	71.8	8.9	74.6	6.8	76.9	5.7	78.3	5.0
30.0	68.0	10.0	70.1	8.5	72.8	6.6	75.0	5.5	76.3	5.0
32.0	66.3	9.4	68.4	8.1	71.0	6.4	73.1	5.4	74.4	4.9
34.0	64.4	8.5	66.6	7.8	69.2	6.2	71.1	5.3	72.3	4.9
36.0	62.6	7.8	64.8	7.4	67.4	6.0	69.2	5.2	70.1	4.8
38.0	60.6	7.1	62.9	7.2	65.4	5.9	67.2	5.1	67.9	4.8
40.0	58.6	6.5	61.0	6.9	63.4	5.7	65.1	5.1	65.6	4.8
42.0	56.6	5.5	59.0	6.6	61.4	5.6	62.9	5.0		
44.0	54.5	5.0	57.0	6.3	59.3	5.4	60.6	4.9		
46.0	52.3	4.5	54.8	5.7	57.2	5.3	58.3	4.9		
48.0	50.0	4.0	52.4	4.8	54.9	5.2	55.8	4.9		
50.0	47.7	3.4	49.9	3.9	52.3	4.5	53.1	4.8		
52.0	45.1	2.6	47.3	3.1	49.5	3.7	50.1	3.9		
54.0	42.3	1.9	44.5	2.4	46.5	2.8				
56.0					43.4	2.1				
危険角度 (°)	39		40		41		45		60	
フック種類	12t		12t		12t		12t		12t	
フック質量 (t)	0.42		0.42		0.42		0.42		0.42	
巻掛本数	1		1		1		1		1	

SS 性能

40.9m ブーム +1.5m+27.3mSL

ブーム オフセット 作業半径 (m)	40.9m ブーム 27.3mSL(5°)		40.9m ブーム 27.3mSL(15°)		40.9m ブーム 27.3mSL(30°)		40.9m ブーム 27.3mSL(45°)		40.9m ブーム 27.3mSL(60°)	
	ブーム角 (°)	荷重 (ton)	ブーム角 (°)	荷重 (ton)	ブーム角 (°)	荷重 (ton)	ブーム角 (°)	荷重 (ton)	ブーム角 (°)	荷重 (ton)
14.0	80.4	7.0								
16.0	78.9	7.0								
18.0	77.4	7.0	81.3	7.0						
20.0	75.9	7.0	79.7	6.9						
22.0	74.3	7.0	78.0	6.5						
24.0	72.7	7.0	76.3	6.1	81.2	4.6				
26.0	71.1	7.0	74.6	5.8	79.3	4.3				
28.0	69.4	6.7	72.8	5.4	77.4	4.1	81.5	3.3		
30.0	67.7	6.3	71.0	5.2	75.6	4.0	79.5	3.2		
32.0	65.8	5.9	69.2	4.9	73.8	3.8	77.5	3.1	80.3	2.7
34.0	64.0	5.6	67.3	4.6	71.8	3.6	75.4	3.0	78.0	2.6
36.0	62.1	5.3	65.4	4.4	69.8	3.5	73.4	2.9	75.6	2.6
38.0	60.2	5.0	63.4	4.2	67.8	3.4	71.1	2.9	73.1	2.6
40.0	58.2	4.7	61.5	4.0	65.7	3.3	68.8	2.8	70.6	2.5
42.0	56.1	4.4	59.4	3.8	63.5	3.1	66.4	2.7	67.9	2.5
44.0	54.1	4.2	57.3	3.6	61.2	3.0	64.1	2.7	65.1	2.5
46.0	51.9	4.0	55.0	3.5	58.8	2.9	61.5	2.6		
48.0	49.7	3.8	52.8	3.4	56.5	2.9	58.7	2.6		
50.0	47.3	3.6	50.3	3.2	53.9	2.8	55.7	2.6		
52.0	44.8	3.5	47.8	3.1	51.1	2.7	52.6	2.5		
54.0	42.2	3.3	45.1	3.0	48.2	2.7				
56.0	39.4	3.2	42.2	2.9	45.0	2.6				
58.0	36.2	2.8	39.0	2.8	41.4	2.6				
60.0	32.7	2.2	35.4	2.6	37.3	2.6				
62.0			31.2	2.0						
危険角度 (°)	27		27		30		45		60	
フック種類	12t		12t		12t		12t		12t	
フック質量 (t)	0.42		0.42		0.42		0.42		0.42	
巻掛本数	1		1		1		1		1	

SS 性能

45.5m ブーム +1.5m+27.3mSL

ブーム オフセット 作業半径 (m)	45.5m ブーム 27.3mSL(5°)		45.5m ブーム 27.3mSL(15°)		45.5m ブーム 27.3mSL(30°)		45.5m ブーム 27.3mSL(45°)		45.5m ブーム 27.3mSL(60°)	
	ブーム角 (°)	荷重 (ton)	ブーム角 (°)	荷重 (ton)	ブーム角 (°)	荷重 (ton)	ブーム角 (°)	荷重 (ton)	ブーム角 (°)	荷重 (ton)
14.0	81.3	7.0								
16.0	80.0	7.0								
18.0	78.6	7.0								
20.0	77.2	7.0	80.7	7.0						
22.0	75.8	7.0	79.3	6.7						
24.0	74.3	7.0	77.7	6.3						
26.0	72.9	7.0	76.2	6.0	80.5	4.4				
28.0	71.4	7.0	74.5	5.6	78.8	4.2				
30.0	69.8	6.6	72.9	5.4	77.2	4.1	80.7	3.3		
32.0	68.2	6.3	71.2	5.1	75.4	3.9	78.9	3.2	81.4	2.7
34.0	66.5	5.9	69.5	4.8	73.6	3.7	77.1	3.1	79.4	2.7
36.0	64.9	5.6	67.8	4.6	71.9	3.6	75.1	3.0	77.3	2.6
38.0	63.1	5.3	66.1	4.4	70.1	3.5	73.2	2.9	75.1	2.6
40.0	61.4	5.0	64.3	4.2	68.2	3.4	71.2	2.8	72.9	2.5
42.0	59.6	4.8	62.5	4.0	66.2	3.2	69.2	2.8	70.6	2.5
44.0	57.7	4.5	60.6	3.8	64.3	3.1	67.0	2.7	68.1	2.5
46.0	55.8	4.3	58.7	3.7	62.3	3.0	64.8	2.7	65.7	2.5
48.0	53.8	4.1	56.7	3.5	60.2	3.0	62.4	2.6		
50.0	51.8	3.9	54.6	3.4	58.0	2.9	60.0	2.6		
52.0	49.6	3.7	52.5	3.3	55.7	2.8	57.5	2.6		
54.0	47.4	3.6	50.2	3.2	53.2	2.7	54.7	2.5		
56.0	45.0	3.1	47.8	3.1	50.7	2.7	51.8	2.5		
58.0	42.3	2.5	45.3	3.0	47.9	2.6				
60.0	39.4	1.9	42.4	2.4	44.9	2.6				
62.0					41.4	2.0				
危険角度 (°)	34		36		36		45		60	
フック種類	12t		12t		12t		12t		12t	
フック質量 (t)	0.42		0.42		0.42		0.42		0.42	
巻掛本数	1		1		1		1		1	

SS 性能

50.0m ブーム +1.5m+27.3mSL

ブーム オフセット 作業半径 (m)	50.0m ブーム 27.3mSL(5°)		50.0m ブーム 27.3mSL(15°)		50.0m ブーム 27.3mSL(30°)		50.0m ブーム 27.3mSL(45°)		50.0m ブーム 27.3mSL(60°)	
	ブーム角 (°)	荷重 (ton)	ブーム角 (°)	荷重 (ton)	ブーム角 (°)	荷重 (ton)	ブーム角 (°)	荷重 (ton)	ブーム角 (°)	荷重 (ton)
16.0	80.5	7.0								
18.0	79.2	7.0								
20.0	78.0	7.0	81.3	7.0						
22.0	76.6	7.0	80.0	6.9						
24.0	75.3	7.0	78.5	6.5						
26.0	74.0	7.0	77.0	6.1	81.1	4.5				
28.0	72.7	7.0	75.6	5.8	79.6	4.3				
30.0	71.3	7.0	74.2	5.6	78.0	4.1	81.3	3.3		
32.0	69.8	6.6	72.7	5.3	76.5	4.0	79.7	3.2		
34.0	68.3	6.2	71.0	5.0	74.9	3.8	78.0	3.1	80.2	2.7
36.0	66.7	5.9	69.5	4.8	73.2	3.7	76.3	3.0	78.3	2.6
38.0	65.2	5.6	67.9	4.6	71.6	3.6	74.4	2.9	76.4	2.6
40.0	63.6	5.3	66.2	4.4	69.8	3.4	72.7	2.9	74.4	2.6
42.0	61.9	5.1	64.6	4.2	68.1	3.3	70.8	2.8	72.3	2.5
44.0	60.3	4.8	62.9	4.0	66.3	3.2	68.9	2.7	70.2	2.5
46.0	58.6	4.6	61.2	3.9	64.5	3.1	67.0	2.7	68.0	2.5
48.0	56.8	4.4	59.4	3.7	62.7	3.0	65.0	2.7	65.6	2.5
50.0	54.9	4.2	57.6	3.6	60.8	3.0	62.8	2.6		
52.0	53.0	4.0	55.6	3.4	58.8	2.9	60.6	2.6		
54.0	50.9	3.5	53.6	3.3	56.6	2.8	58.3	2.5		
56.0	48.7	2.8	51.6	3.2	54.4	2.8	55.8	2.5		
58.0	46.3	2.2	49.3	2.8	52.2	2.7	53.1	2.5		
60.0			46.8	2.2	49.7	2.7	50.3	2.5		
62.0					46.8	2.0				
危険角度 (°)	41		41		42		45		60	
フック種類	12t		12t		12t		12t		12t	
フック質量 (t)	0.42		0.42		0.42		0.42		0.42	
巻掛本数	1		1		1		1		1	

HA 性能

13.6m ブーム +4.4m+13.0m ヘビーリフトジブ

オフセット	10°	20°	30°	45°	60°
作業半径 (m)	荷重 (ton)	荷重 (ton)	荷重 (ton)	荷重 (ton)	荷重 (ton)
7.0	84.0				
8.0	84.0	84.0			
9.0	84.0	80.1			
10.0	80.8	76.0	65.8		
11.0	75.6	72.2	63.2		
12.0	70.0	68.9	60.7	50.9	
14.0	58.3	59.5	56.6	48.1	34.2
16.0	49.5	50.5	51.5	45.8	33.3
18.0	42.7	43.5	44.3	44.0	32.7
20.0	37.3	37.8	38.3	38.9	
22.0	32.3	32.7	33.0	33.4	
24.0	28.2	28.6	28.8		
26.0	25.0	25.2	25.3		
28.0	22.3				
危険角度 (°)	10	20	30	45	60
フック種類	120t	120t	120t	120t	120t
フック質量 (t)	1.90	1.90	1.90	1.90	1.90
巻掛本数	8	8	8	8	8

HA 性能

22.7m ブーム +4.4m+13.0m ヘビーリフトジブ

オフセット	10°	20°	30°	45°	60°
作業半径 (m)	荷重 (ton)	荷重 (ton)	荷重 (ton)	荷重 (ton)	荷重 (ton)
8.0	64.0				
9.0	64.0				
10.0	64.0	64.0			
11.0	64.0	64.0			
12.0	64.0	64.0	64.0		
14.0	54.6	56.5	58.3	51.8	
16.0	45.8	47.4	48.9	49.8	38.6
18.0	39.0	40.3	41.5	43.1	37.8
20.0	33.5	34.6	35.7	36.9	37.3
22.0	29.0	30.0	30.7	31.5	31.9
24.0	25.2	25.8	26.4	27.1	
26.0	21.9	22.5	22.9	23.4	
28.0	19.2	19.7	20.0	20.4	
30.0	16.9	17.3	17.6		
32.0	15.0	15.2	15.4		
34.0	13.2	13.4	13.5		
36.0	11.6	11.7			
危険角度 (°)	10	20	30	45	60
フック種類	83t	83t	83t	83t	83t
フック質量 (t)	1.00	1.00	1.00	1.00	1.00
巻掛本数	6	6	6	6	6

HA 性能

18.15m ブーム +4.4m+13.0m ヘビーリフトジブ

オフセット	10°	20°	30°	45°	60°
作業半径 (m)	荷重 (ton)	荷重 (ton)	荷重 (ton)	荷重 (ton)	荷重 (ton)
7.0	77.0				
8.0	77.0				
9.0	77.0	77.0			
10.0	77.0	77.0			
11.0	74.8	76.2	65.2		
12.0	67.8	69.8	63.0		
14.0	56.1	57.7	59.0	50.6	
16.0	47.3	48.6	49.9	48.4	36.2
18.0	40.5	41.6	42.6	43.9	35.5
20.0	35.0	36.0	36.8	37.7	35.1
22.0	30.4	31.1	31.6	32.2	
24.0	26.4	26.9	27.4	27.8	
26.0	23.2	23.6	23.9	24.2	
28.0	20.5	20.8	21.0		
30.0	18.2	18.4	18.5		
32.0	16.2	16.3			
危険角度 (°)	10	20	30	45	60
フック種類	120t	120t	120t	120t	120t
フック質量 (t)	1.90	1.90	1.90	1.90	1.90
巻掛本数	8	8	8	8	8

HA 性能

31.8m ブーム +4.4m+13.0m ヘビーリフトジブ

オフセット	10°	20°	30°	45°	60°
作業半径 (m)	荷重 (ton)	荷重 (ton)	荷重 (ton)	荷重 (ton)	荷重 (ton)
10.0	45.0				
11.0	44.8	40.3			
12.0	44.1	39.8			
14.0	42.8	38.8	35.3		
16.0	41.7	38.0	34.7	30.2	
18.0	38.8	37.2	34.1	29.8	25.8
20.0	33.3	34.6	33.7	29.6	25.8
22.0	28.8	29.9	30.7	29.5	25.8
24.0	25.0	25.8	26.5	27.3	25.8
26.0	21.7	22.4	23.0	23.7	24.0
28.0	19.0	19.6	20.1	20.7	20.9
30.0	16.7	17.2	17.7	18.1	
32.0	14.8	15.2	15.6	15.9	
34.0	13.0	13.4	13.7	14.0	
36.0	11.3	11.8	12.1		
38.0	9.9	10.3	10.5		
40.0	8.6	8.9	9.0		
42.0	7.4	7.6			
44.0	6.4	6.5			
46.0	5.4				
危険角度 (°)	10	20	30	45	60
フック種類	83t	83t	83t	83t	83t
フック質量 (t)	1.00	1.00	1.00	1.00	1.00
巻掛本数	4	4	4	4	4

HA 性能

13.6m ブーム +4.4m+22.0m ヘビーリフトジブ

オフセット	10°	20°	30°	45°	60°
作業半径 (m)	荷重 (ton)	荷重 (ton)	荷重 (ton)	荷重 (ton)	荷重 (ton)
10.0	54.0				
11.0	54.0				
12.0	54.0				
14.0	54.0	47.4			
16.0	49.9	43.1	38.0		
18.0	44.9	39.5	35.3		
20.0	39.2	36.6	33.0	28.1	
22.0	34.1	34.0	31.0	26.8	19.4
24.0	30.0	30.7	29.3	25.7	18.9
26.0	26.6	27.2	27.8	24.7	18.6
28.0	23.8	24.3	24.8	23.9	18.4
30.0	21.4	21.9	22.3	22.8	
32.0	19.4	19.8	20.1	20.4	
34.0	17.7	17.9	18.1		
36.0	16.2	16.3			
危険角度 (°)	10	20	30	45	60
フック種類	83t	83t	83t	83t	83t
フック質量 (t)	1.00	1.00	1.00	1.00	1.00
巻掛本数	6	6	6	6	6

HA 性能

22.7m ブーム +4.4m+22.0m ヘビーリフトジブ

オフセット	10°	20°	30°	45°	60°
作業半径 (m)	荷重 (ton)	荷重 (ton)	荷重 (ton)	荷重 (ton)	荷重 (ton)
11.0	45.0				
12.0	45.0				
14.0	45.0				
16.0	45.0	45.0			
18.0	41.9	44.0	39.5		
20.0	36.3	38.2	37.2		
22.0	31.5	32.9	34.2	30.0	
24.0	27.4	28.6	29.7	28.9	22.1
26.0	24.0	25.1	26.0	27.3	21.7
28.0	21.2	22.1	23.0	24.1	21.3
30.0	18.9	19.7	20.4	21.3	21.1
32.0	16.8	17.5	18.2	18.9	19.4
34.0	15.1	15.7	16.2	16.9	
36.0	13.6	14.1	14.5	15.0	
38.0	12.2	12.6	13.0	13.3	
40.0	11.0	11.3	11.6		
42.0	9.9	10.2	10.4		
44.0	8.8	9.0			
46.0	7.7				
危険角度 (°)	10	20	30	45	60
フック種類	83t	83t	83t	83t	83t
フック質量 (t)	1.00	1.00	1.00	1.00	1.00
巻掛本数	4	4	4	4	4

HA 性能

18.15m ブーム +4.4m+22.0m ヘビーリフトジブ

オフセット	10°	20°	30°	45°	60°
作業半径 (m)	荷重 (ton)	荷重 (ton)	荷重 (ton)	荷重 (ton)	荷重 (ton)
10.0	50.0				
11.0	50.0				
12.0	50.0				
14.0	50.0	49.4			
16.0	50.0	45.2			
18.0	43.1	41.7	36.4		
20.0	37.5	38.7	34.3		
22.0	32.5	33.7	32.3	28.2	
24.0	28.4	29.4	30.3	27.1	20.6
26.0	25.1	25.9	26.7	26.2	20.2
28.0	22.3	23.0	23.7	24.6	19.9
30.0	19.9	20.6	21.1	21.9	19.7
32.0	17.9	18.4	18.9	19.5	
34.0	16.2	16.6	17.0	17.4	
36.0	14.6	15.0	15.3		
38.0	13.3	13.6	13.8		
40.0	12.1	12.3			
42.0	11.0				
危険角度 (°)	10	20	30	45	60
フック種類	83t	83t	83t	83t	83t
フック質量 (t)	1.00	1.00	1.00	1.00	1.00
巻掛本数	6	6	6	6	6

HA 性能

31.8m ブーム +4.4m+22.0m ヘビーリフトジブ

オフセット	10°	20°	30°	45°	60°
作業半径 (m)	荷重 (ton)	荷重 (ton)	荷重 (ton)	荷重 (ton)	荷重 (ton)
14.0	30.0				
16.0	30.0	29.8			
18.0	30.0	28.9			
20.0	30.0	28.0	25.2		
22.0	30.0	27.3	24.6		
24.0	26.8	26.6	24.1	20.6	
26.0	23.4	24.6	23.7	20.3	17.0
28.0	20.6	21.7	22.6	20.1	16.9
30.0	18.3	19.2	20.1	19.9	16.9
32.0	16.3	17.1	17.9	18.8	16.9
34.0	14.5	15.2	15.9	16.8	16.9
36.0	13.0	13.6	14.2	14.9	15.3
38.0	11.6	12.2	12.7	13.3	
40.0	10.3	11.0	11.4	11.9	
42.0	9.1	9.7	10.2	10.6	
44.0	8.0	8.6	9.0	9.4	
46.0	7.0	7.5	7.8		
48.0	6.1	6.5	6.8		
50.0	5.3	5.6	5.8		
55.0	3.5				
危険角度 (°)	10	20	30	45	60
フック種類	83t	83t	83t	83t	83t
フック質量 (t)	1.00	1.00	1.00	1.00	1.00
巻掛本数	4	4	4	4	4

HA 性能

40.9m ブーム +4.4m+22.0m ヘビーリフトジブ

オフセット	10°	20°	30°	45°	60°
作業半径 (m)	荷重 (ton)	荷重 (ton)	荷重 (ton)	荷重 (ton)	荷重 (ton)
16.0	20.0				
18.0	20.0				
20.0	20.0	20.0			
22.0	20.0	20.0	20.0		
24.0	20.0	20.0	20.0		
26.0	20.0	20.0	20.0	20.0	
28.0	20.0	20.0	20.0	20.0	20.0
30.0	18.1	19.1	20.0	20.0	20.0
32.0	16.1	17.0	17.9	18.9	19.7
34.0	14.3	15.2	15.9	16.9	17.5
36.0	12.8	13.5	14.2	15.1	15.6
38.0	11.4	12.1	12.7	13.5	13.9
40.0	10.0	10.9	11.4	12.0	12.4
42.0	8.8	9.6	10.2	10.8	
44.0	7.7	8.4	9.0	9.6	
46.0	6.7	7.3	7.9	8.4	
48.0	5.8	6.4	6.8	7.3	
50.0	4.9	5.4	5.8	6.2	
55.0	3.1	3.4	3.7		
危険角度 (°)	28	28	30	45	60
フック種類	24t	24t	24t	24t	24t
フック質量 (t)	0.88	0.88	0.88	0.88	0.88
巻掛本数	2	2	2	2	2

HA 性能

50.0m ブーム +4.4m+22.0m ヘビーリフトジブ

オフセット	10°	20°	30°	45°	60°
作業半径 (m)	荷重 (ton)	荷重 (ton)	荷重 (ton)	荷重 (ton)	荷重 (ton)
18.0	11.0				
20.0	11.0				
22.0	11.0	11.0			
24.0	11.0	11.0	11.0		
26.0	11.0	11.0	11.0		
28.0	11.0	11.0	10.9	9.1	
30.0	11.0	11.0	10.8	9.1	7.5
32.0	11.0	11.0	10.6	9.0	7.5
34.0	11.0	11.0	10.5	9.0	7.5
36.0	11.0	11.0	10.4	8.9	7.5
38.0	10.9	11.0	10.4	8.9	7.5
40.0	9.6	10.5	10.3	8.9	7.5
42.0	8.4	9.2	10.0	8.9	7.5
44.0	7.3	8.1	8.8	8.9	7.5
46.0	6.3	7.0	7.6	8.4	
48.0	5.3	6.0	6.6	7.2	
50.0	4.5	5.1	5.6	6.2	
55.0		3.1	3.5	3.9	
危険角度 (°)	41	42	42	45	60
フック種類	24t	24t	24t	24t	24t
フック質量 (t)	0.88	0.88	0.88	0.88	0.88
巻掛本数	2	2	2	2	2

HA 性能

45.5m ブーム +4.4m+22.0m ヘビーリフトジブ

オフセット	10°	20°	30°	45°	60°
作業半径 (m)	荷重 (ton)	荷重 (ton)	荷重 (ton)	荷重 (ton)	荷重 (ton)
16.0	16.0				
18.0	16.0				
20.0	16.0	16.0			
22.0	16.0	16.0			
24.0	16.0	16.0	16.0		
26.0	16.0	16.0	16.0		
28.0	16.0	16.0	16.0	15.6	
30.0	16.0	16.0	16.0	15.4	13.0
32.0	15.9	16.0	16.0	15.3	13.0
34.0	14.1	15.0	15.8	15.2	12.9
36.0	12.6	13.4	14.1	15.0	12.9
38.0	11.1	12.0	12.6	13.4	12.9
40.0	9.8	10.7	11.3	12.0	12.4
42.0	8.6	9.4	10.1	10.7	11.0
44.0	7.5	8.2	8.9	9.6	
46.0	6.5	7.2	7.8	8.4	
48.0	5.6	6.2	6.7	7.3	
50.0	4.7	5.3	5.8	6.2	
55.0	2.9	3.3	3.6		
危険角度 (°)	36	36	36	45	60
フック種類	24t	24t	24t	24t	24t
フック質量 (t)	0.88	0.88	0.88	0.88	0.88
巻掛本数	2	2	2	2	2

HA 性能

13.6m ブーム +4.4m+31.0m ヘビーリフトジブ

オフセット	10°	20°	30°	45°	60°
作業半径 (m)	荷重 (ton)	荷重 (ton)	荷重 (ton)	荷重 (ton)	荷重 (ton)
14.0	35.0				
16.0	34.4				
18.0	34.4	33.8			
20.0	34.4	31.5			
22.0	32.8	29.1	26.1		
24.0	30.2	27.1	24.5		
26.0	27.7	25.3	23.1		
28.0	24.9	23.7	21.8	18.8	
30.0	22.5	22.4	20.7	18.0	
32.0	20.4	21.0	19.7	17.3	12.7
34.0	18.6	19.1	18.9	16.7	12.4
36.0	17.0	17.5	18.0	16.2	12.2
38.0	15.7	16.1	16.5	15.8	
40.0	14.4	14.8	15.1	15.5	
42.0	13.4	13.6	13.9		
44.0	12.4	12.6	12.7		
46.0	11.5				
危険角度 (°)	10	20	30	45	60
フック種類	83t	83t	83t	83t	83t
フック質量 (t)	1.00	1.00	1.00	1.00	1.00
巻掛本数	4	4	4	4	4

HA 性能

22.7m ブーム +4.4m+31.0m ヘビーリフトジブ

オフセット	10°	20°	30°	45°	60°
作業半径 (m)	荷重 (ton)	荷重 (ton)	荷重 (ton)	荷重 (ton)	荷重 (ton)
16.0	30.0				
18.0	30.0				
20.0	30.0	30.0			
22.0	30.0	30.0			
24.0	28.8	29.6	25.8		
26.0	25.3	26.8	24.5		
28.0	22.5	23.8	23.3		
30.0	20.1	21.2	22.2	19.4	
32.0	18.0	19.0	20.0	18.7	
34.0	16.2	17.1	18.0	18.2	14.5
36.0	14.7	15.5	16.3	17.4	14.2
38.0	13.3	14.0	14.7	15.7	14.1
40.0	12.1	12.7	13.3	14.2	13.9
42.0	11.0	11.5	12.1	12.8	
44.0	10.0	10.5	11.0	11.5	
46.0	9.1	9.5	9.9	10.4	
48.0	8.1	8.6	9.0		
50.0	7.3	7.7	8.0		
55.0	5.4				
危険角度 (°)	10	20	30	45	60
フック種類	83t	83t	83t	83t	83t
フック質量 (t)	1.00	1.00	1.00	1.00	1.00
巻掛本数	4	4	4	4	4

HA 性能

18.15m ブーム +4.4m+31.0m ヘビーリフトジブ

オフセット	10°	20°	30°	45°	60°
作業半径 (m)	荷重 (ton)	荷重 (ton)	荷重 (ton)	荷重 (ton)	荷重 (ton)
14.0	34.0				
16.0	34.0				
18.0	34.0	34.0			
20.0	34.0	32.8			
22.0	34.0	30.4	26.8		
24.0	29.9	28.4	25.2		
26.0	26.4	26.6	23.8		
28.0	23.6	24.6	22.6	19.8	
30.0	21.2	22.1	21.5	19.1	
32.0	19.1	19.9	20.6	18.4	13.9
34.0	17.3	18.1	18.8	17.8	13.6
36.0	15.8	16.4	17.1	17.3	13.4
38.0	14.4	15.0	15.5	16.3	13.2
40.0	13.2	13.7	14.1	14.8	
42.0	12.1	12.5	12.9	13.4	
44.0	11.1	11.4	11.8	12.1	
46.0	10.2	10.5	10.7		
48.0	9.4	9.6	9.7		
50.0	8.6				
危険角度 (°)	10	20	30	45	60
フック種類	83t	83t	83t	83t	83t
フック質量 (t)	1.00	1.00	1.00	1.00	1.00
巻掛本数	4	4	4	4	4

HA 性能

31.8m ブーム +4.4m+31.0m ヘビーリフトジブ

オフセット	10°	20°	30°	45°	60°
作業半径 (m)	荷重 (ton)	荷重 (ton)	荷重 (ton)	荷重 (ton)	荷重 (ton)
16.0	20.0				
18.0	20.0				
20.0	20.0				
22.0	20.0	20.0			
24.0	20.0	20.0			
26.0	20.0	20.0	19.4		
28.0	20.0	20.0	18.9		
30.0	19.7	20.0	18.5	15.6	
32.0	17.6	18.8	18.1	15.3	
34.0	15.8	16.9	17.7	15.1	12.4
36.0	14.2	15.2	16.1	14.9	12.3
38.0	12.9	13.7	14.6	14.7	12.3
40.0	11.6	12.4	13.2	14.2	12.2
42.0	10.5	11.3	11.9	12.8	12.2
44.0	9.5	10.2	10.8	11.6	12.0
46.0	8.4	9.2	9.8	10.4	10.8
48.0	7.5	8.2	8.8	9.4	
50.0	6.6	7.3	7.9	8.4	
55.0	4.7	5.2	5.6		
60.0	3.2	3.4			
危険角度 (°)	13	20	30	45	60
フック種類	24t	24t	24t	24t	24t
フック質量 (t)	0.88	0.88	0.88	0.88	0.88
巻掛本数	2	2	2	2	2

HA 性能

40.9m ブーム +4.4m+31.0m ヘビーリフトジブ

オフセット	10°	20°	30°	45°	60°
作業半径 (m)	荷重 (ton)	荷重 (ton)	荷重 (ton)	荷重 (ton)	荷重 (ton)
18.0	14.0				
20.0	14.0				
22.0	14.0				
24.0	14.0	14.0			
26.0	14.0	14.0			
28.0	14.0	14.0	14.0		
30.0	14.0	14.0	14.0		
32.0	14.0	14.0	14.0		
34.0	14.0	14.0	14.0	14.0	
36.0	13.7	14.0	14.0	14.0	
38.0	12.3	13.3	14.0	14.0	14.0
40.0	11.1	12.0	12.9	14.0	14.0
42.0	9.9	10.9	11.6	12.6	13.4
44.0	8.8	9.8	10.5	11.4	12.0
46.0	7.7	8.7	9.5	10.3	10.8
48.0	6.8	7.7	8.5	9.3	9.7
50.0	5.9	6.8	7.5	8.4	8.7
55.0	4.1	4.7	5.3	5.9	
60.0		3.0	3.4	3.8	
危険角度 (°)	36	37	37	45	60
フック種類	24t	24t	24t	24t	24t
フック質量 (t)	0.88	0.88	0.88	0.88	0.88
巻掛本数	2	2	2	2	2

HA 性能

50.0m ブーム +4.4m+31.0m ヘビーリフトジブ

オフセット	10°	20°	30°	45°	60°
作業半径 (m)	荷重 (ton)	荷重 (ton)	荷重 (ton)	荷重 (ton)	荷重 (ton)
20.0	9.0				
22.0	9.0				
24.0	9.0				
26.0	9.0	9.0			
28.0	9.0	9.0			
30.0	9.0	9.0	7.8		
32.0	9.0	8.8	7.7		
34.0	9.0	8.6	7.5		
36.0	9.0	8.4	7.4	6.0	
38.0	9.0	8.2	7.3	5.9	4.7
40.0	9.0	8.1	7.2	5.9	4.6
42.0	8.9	8.0	7.1	5.8	4.6
44.0	8.2	7.9	7.0	5.8	4.6
46.0	7.2	7.8	7.0	5.8	4.6
48.0	6.2	7.3	6.9	5.8	4.6
50.0	5.4	6.3	6.9	5.8	4.6
55.0	3.5	4.3	5.0	5.8	
60.0			3.1	3.7	
危険角度 (°)	47	47	48	48	60
フック種類	24t	24t	24t	24t	24t
フック質量 (t)	0.88	0.88	0.88	0.88	0.88
巻掛本数	2	2	2	2	2

HA 性能

45.5m ブーム +4.4m+31.0m ヘビーリフトジブ

オフセット	10°	20°	30°	45°	60°
作業半径 (m)	荷重 (ton)	荷重 (ton)	荷重 (ton)	荷重 (ton)	荷重 (ton)
20.0	12.0				
22.0	12.0				
24.0	12.0	12.0			
26.0	12.0	12.0			
28.0	12.0	12.0			
30.0	12.0	12.0	12.0		
32.0	12.0	12.0	12.0		
34.0	12.0	12.0	12.0	11.1	
36.0	12.0	12.0	12.0	11.0	
38.0	12.0	12.0	12.0	10.9	8.9
40.0	10.8	11.8	12.0	10.8	8.9
42.0	9.6	10.7	11.5	10.7	8.8
44.0	8.5	9.6	10.4	10.6	8.8
46.0	7.4	8.5	9.4	10.2	8.8
48.0	6.5	7.5	8.4	9.2	8.8
50.0	5.6	6.5	7.4	8.3	8.7
55.0	3.8	4.5	5.2	5.9	
60.0		2.8	3.3	3.8	
危険角度 (°)	42	43	43	45	60
フック種類	24t	24t	24t	24t	24t
フック質量 (t)	0.88	0.88	0.88	0.88	0.88
巻掛本数	2	2	2	2	2

HA 性能

13.6m ブーム +4.4m+40.0m ヘビーリフトジブ

オフセット	10°	20°	30°	45°	60°
作業半径 (m)	荷重 (ton)	荷重 (ton)	荷重 (ton)	荷重 (ton)	荷重 (ton)
16.0	12.0				
18.0	12.0				
20.0	12.0				
22.0	12.0	12.0			
24.0	12.0	12.0			
26.0	12.0	12.0			
28.0	12.0	12.0	12.0		
30.0	12.0	12.0	12.0		
32.0	12.0	12.0	12.0		
34.0	12.0	12.0	12.0		
36.0	12.0	12.0	12.0	11.8	
38.0	12.0	12.0	12.0	11.2	
40.0	12.0	12.0	11.9	10.7	9.4
42.0	12.0	12.0	11.3	10.2	9.2
44.0	12.0	11.5	10.7	9.8	9.0
46.0	11.6	10.9	10.3	9.5	8.9
48.0	10.9	10.3	9.8	9.2	
50.0	10.3	9.9	9.5	9.0	
55.0	9.1				
危険角度 (°)	10	20	30	45	60
フック種類	12t	12t	12t	12t	12t
フック質量 (t)	0.53	0.53	0.53	0.53	0.53
巻掛本数	1	1	1	1	1

HA 性能

22.7m ブーム +4.4m+40.0m ヘビーリフトジブ

オフセット	10°	20°	30°	45°	60°
作業半径 (m)	荷重 (ton)	荷重 (ton)	荷重 (ton)	荷重 (ton)	荷重 (ton)
18.0	12.0				
20.0	12.0				
22.0	12.0				
24.0	12.0	12.0			
26.0	12.0	12.0			
28.0	12.0	12.0			
30.0	12.0	12.0	12.0		
32.0	12.0	12.0	12.0		
34.0	12.0	12.0	12.0		
36.0	12.0	12.0	12.0	12.0	
38.0	12.0	12.0	12.0	11.7	
40.0	12.0	12.0	12.0	11.3	
42.0	12.0	12.0	12.0	10.8	9.7
44.0	11.2	12.0	11.9	10.5	9.5
46.0	10.3	11.0	11.4	10.1	9.3
48.0	9.5	10.1	10.7	9.8	9.1
50.0	8.7	9.3	9.8	9.5	9.0
55.0	6.9	7.5	7.9	8.3	
60.0	5.3	5.7	6.0		
危険角度 (°)	10	20	30	45	60
フック種類	12t	12t	12t	12t	12t
フック質量 (t)	0.53	0.53	0.53	0.53	0.53
巻掛本数	1	1	1	1	1

HA 性能

18.15m ブーム +4.4m+40.0m ヘビーリフトジブ

オフセット	10°	20°	30°	45°	60°
作業半径 (m)	荷重 (ton)	荷重 (ton)	荷重 (ton)	荷重 (ton)	荷重 (ton)
18.0	12.0				
20.0	12.0				
22.0	12.0				
24.0	12.0	12.0			
26.0	12.0	12.0			
28.0	12.0	12.0			
30.0	12.0	12.0	12.0		
32.0	12.0	12.0	12.0		
34.0	12.0	12.0	12.0		
36.0	12.0	12.0	12.0	12.0	
38.0	12.0	12.0	12.0	11.5	
40.0	12.0	12.0	12.0	11.0	9.9
42.0	12.0	12.0	11.9	10.6	9.6
44.0	12.0	12.0	11.4	10.2	9.3
46.0	11.3	11.7	10.9	9.8	9.2
48.0	10.4	10.9	10.4	9.5	9.0
50.0	9.7	10.1	10.0	9.3	
55.0	8.0	8.3	8.5		
60.0	6.6				
危険角度 (°)	10	20	30	45	60
フック種類	12t	12t	12t	12t	12t
フック質量 (t)	0.53	0.53	0.53	0.53	0.53
巻掛本数	1	1	1	1	1

HA 性能

31.8m ブーム +4.4m+40.0m ヘビーリフトジブ

オフセット	10°	20°	30°	45°	60°
作業半径 (m)	荷重 (ton)	荷重 (ton)	荷重 (ton)	荷重 (ton)	荷重 (ton)
20.0	12.0				
22.0	12.0				
24.0	12.0				
26.0	12.0	12.0			
28.0	12.0	12.0			
30.0	12.0	12.0			
32.0	12.0	12.0	12.0		
34.0	12.0	12.0	12.0		
36.0	12.0	12.0	12.0		
38.0	12.0	12.0	12.0	12.0	
40.0	12.0	12.0	12.0	11.7	
42.0	11.6	12.0	12.0	11.3	
44.0	10.6	11.5	12.0	10.9	9.5
46.0	9.7	10.5	11.3	10.6	9.4
48.0	8.8	9.6	10.3	10.3	9.3
50.0	8.0	8.8	9.5	10.0	9.2
55.0	6.1	6.9	7.5	8.2	8.5
60.0	4.5	5.1	5.7	6.3	
65.0	3.1	3.5	3.9		
70.0	1.9	2.1			
危険角度 (°)	11	20	30	45	60
フック種類	12t	12t	12t	12t	12t
フック質量 (t)	0.53	0.53	0.53	0.53	0.53
巻掛本数	1	1	1	1	1

HA 性能

40.9m ブーム +4.4m+40.0m ヘビーリフトジブ

オフセット	10°	20°	30°	45°	60°
作業半径 (m)	荷重 (ton)	荷重 (ton)	荷重 (ton)	荷重 (ton)	荷重 (ton)
22.0	11.0				
24.0	11.0				
26.0	11.0				
28.0	11.0	11.0			
30.0	11.0	11.0			
32.0	11.0	11.0			
34.0	11.0	11.0	11.0		
36.0	11.0	11.0	11.0		
38.0	11.0	11.0	11.0		
40.0	11.0	11.0	11.0		
42.0	11.0	11.0	11.0	11.0	
44.0	10.1	11.0	11.0	11.0	
46.0	9.1	10.1	11.0	11.0	9.6
48.0	8.1	9.2	10.0	10.7	9.5
50.0	7.3	8.4	9.1	10.2	9.3
55.0	5.3	6.3	7.2	8.0	8.6
60.0	3.7	4.5	5.3	6.1	
65.0	2.4	3.0	3.6	4.2	
70.0		1.7	2.1		
危険角度 (°)	35	36	36	45	60
フック種類	12t	12t	12t	12t	12t
フック質量 (t)	0.53	0.53	0.53	0.53	0.53
巻掛本数	1	1	1	1	1

HA 性能

50.0m ブーム +4.4m+40.0m ヘビーリフトジブ

オフセット	10°	20°	30°	45°	60°
作業半径 (m)	荷重 (ton)	荷重 (ton)	荷重 (ton)	荷重 (ton)	荷重 (ton)
24.0	7.0				
26.0	7.0				
28.0	7.0				
30.0	7.0	7.0			
32.0	7.0	7.0			
34.0	7.0	7.0			
36.0	7.0	6.8	5.9		
38.0	7.0	6.7	5.8		
40.0	7.0	6.5	5.6		
42.0	7.0	6.4	5.5		
44.0	7.0	6.2	5.4	4.3	
46.0	6.9	6.1	5.3	4.2	
48.0	6.7	6.0	5.2	4.2	3.1
50.0	6.6	5.9	5.2	4.1	3.1
55.0	4.7	5.7	5.0	4.1	3.1
60.0	3.1	4.1	4.9	4.1	3.1
65.0	1.8	2.5	3.3	4.1	
70.0			1.8	2.4	
危険角度 (°)	47	48	48	48	60
フック種類	12t	12t	12t	12t	12t
フック質量 (t)	0.53	0.53	0.53	0.53	0.53
巻掛本数	1	1	1	1	1

HA 性能

45.5m ブーム +4.4m+40.0m ヘビーリフトジブ

オフセット	10°	20°	30°	45°	60°
作業半径 (m)	荷重 (ton)	荷重 (ton)	荷重 (ton)	荷重 (ton)	荷重 (ton)
24.0	10.0				
26.0	10.0				
28.0	10.0				
30.0	10.0	10.0			
32.0	10.0	10.0			
34.0	10.0	10.0			
36.0	10.0	10.0	10.0		
38.0	10.0	10.0	10.0		
40.0	10.0	10.0	10.0		
42.0	10.0	10.0	10.0	8.5	
44.0	9.8	10.0	10.0	8.3	
46.0	8.8	9.9	9.9	8.2	6.6
48.0	7.8	9.0	9.8	8.1	6.5
50.0	6.9	8.1	9.0	8.1	6.5
55.0	5.0	6.0	7.0	7.9	6.5
60.0	3.4	4.3	5.1	6.0	6.5
65.0	2.1	2.8	3.4	4.2	
70.0		1.5	2.0	2.5	
危険角度 (°)	41	42	42	45	60
フック種類	12t	12t	12t	12t	12t
フック質量 (t)	0.53	0.53	0.53	0.53	0.53
巻掛本数	1	1	1	1	1

HA 性能

13.6m ブーム +4.4m+47.0m ヘビーリフトジブ

オフセット	10°	20°	30°	45°	60°
作業半径 (m)	荷重 (ton)	荷重 (ton)	荷重 (ton)	荷重 (ton)	荷重 (ton)
18.0	12.0				
20.0	12.0				
22.0	12.0				
24.0	12.0				
26.0	12.0	12.0			
28.0	12.0	12.0			
30.0	12.0	12.0			
32.0	12.0	12.0	12.0		
34.0	12.0	12.0	12.0		
36.0	12.0	12.0	11.7		
38.0	12.0	12.0	10.9		
40.0	12.0	11.2	10.3		
42.0	11.5	10.5	9.7	8.6	
44.0	10.8	9.9	9.2	8.2	
46.0	10.1	9.4	8.7	7.8	7.1
48.0	9.5	8.8	8.2	7.5	6.9
50.0	8.9	8.4	7.9	7.2	6.7
55.0	7.8	7.4	7.1	6.6	
60.0	6.9	6.7	6.5		
危険角度 (°)	10	20	30	45	60
フック種類	12t	12t	12t	12t	12t
フック質量 (t)	0.53	0.53	0.53	0.53	0.53
巻掛本数	1	1	1	1	1

HA 性能

22.7m ブーム +4.4m+47.0m ヘビーリフトジブ

オフセット	10°	20°	30°	45°	60°
作業半径 (m)	荷重 (ton)	荷重 (ton)	荷重 (ton)	荷重 (ton)	荷重 (ton)
20.0	12.0				
22.0	12.0				
24.0	12.0				
26.0	12.0				
28.0	12.0	12.0			
30.0	12.0	12.0			
32.0	12.0	12.0			
34.0	12.0	12.0	12.0		
36.0	12.0	12.0	12.0		
38.0	12.0	12.0	11.7		
40.0	12.0	12.0	11.1		
42.0	12.0	11.9	10.5	8.9	
44.0	11.7	11.2	10.0	8.6	
46.0	10.8	10.6	9.5	8.2	
48.0	9.9	10.1	9.1	7.9	7.1
50.0	9.2	9.6	8.7	7.6	6.9
55.0	7.5	8.1	7.8	7.0	6.5
60.0	5.9	6.5	7.0	6.6	
65.0	4.5	5.0	5.3		
70.0	3.3	3.5			
危険角度 (°)	10	20	30	45	60
フック種類	12t	12t	12t	12t	12t
フック質量 (t)	0.53	0.53	0.53	0.53	0.53
巻掛本数	1	1	1	1	1

HA 性能

18.15m ブーム +4.4m+47.0m ヘビーリフトジブ

オフセット	10°	20°	30°	45°	60°
作業半径 (m)	荷重 (ton)	荷重 (ton)	荷重 (ton)	荷重 (ton)	荷重 (ton)
20.0	12.0				
22.0	12.0				
24.0	12.0				
26.0	12.0	12.0			
28.0	12.0	12.0			
30.0	12.0	12.0			
32.0	12.0	12.0			
34.0	12.0	12.0	12.0		
36.0	12.0	12.0	12.0		
38.0	12.0	12.0	11.3		
40.0	12.0	12.0	10.7		
42.0	12.0	11.2	10.1	8.8	
44.0	11.7	10.6	9.6	8.4	
46.0	11.0	10.0	9.1	8.0	
48.0	10.4	9.5	8.7	7.7	7.0
50.0	9.8	9.0	8.3	7.4	6.8
55.0	8.4	8.0	7.4	6.8	6.5
60.0	7.0	7.1	6.8	6.5	
65.0	5.8	6.0			
危険角度 (°)	10	20	30	45	60
フック種類	12t	12t	12t	12t	12t
フック質量 (t)	0.53	0.53	0.53	0.53	0.53
巻掛本数	1	1	1	1	1

HA 性能

31.8m ブーム +4.4m+47.0m ヘビーリフトジブ

オフセット	10°	20°	30°	45°	60°
作業半径 (m)	荷重 (ton)	荷重 (ton)	荷重 (ton)	荷重 (ton)	荷重 (ton)
22.0	12.0				
24.0	12.0				
26.0	12.0				
28.0	12.0				
30.0	12.0	12.0			
32.0	12.0	12.0			
34.0	12.0	12.0			
36.0	12.0	12.0	12.0		
38.0	12.0	12.0	12.0		
40.0	12.0	12.0	11.8		
42.0	12.0	12.0	11.2		
44.0	11.0	12.0	10.7	8.8	
46.0	10.1	11.1	10.2	8.5	
48.0	9.3	10.2	9.8	8.2	
50.0	8.5	9.4	9.4	8.0	7.0
55.0	6.6	7.6	8.2	7.4	6.7
60.0	5.0	5.8	6.6	6.9	6.5
65.0	3.6	4.3	4.9	5.7	
70.0	2.4	2.9	3.4	3.8	
75.0	1.4	1.7	2.0		
危険角度 (°)	21	21	30	45	60
フック種類	12t	12t	12t	12t	12t
フック質量 (t)	0.53	0.53	0.53	0.53	0.53
巻掛本数	1	1	1	1	1

HA 性能

40.9m ブーム +4.4m+47.0m ヘビーリフトジブ

オフセット	10°	20°	30°	45°	60°
作業半径 (m)	荷重 (ton)	荷重 (ton)	荷重 (ton)	荷重 (ton)	荷重 (ton)
26.0	8.0				
28.0	8.0				
30.0	8.0				
32.0	8.0	8.0			
34.0	8.0	8.0			
36.0	8.0	8.0			
38.0	8.0	8.0			
40.0	8.0	8.0	8.0		
42.0	8.0	8.0	8.0		
44.0	8.0	8.0	8.0		
46.0	8.0	8.0	8.0		
48.0	8.0	8.0	8.0	8.0	
50.0	7.8	8.0	8.0	8.0	
55.0	5.8	7.0	7.9	7.7	6.8
60.0	4.2	5.2	6.1	7.2	6.6
65.0	2.8	3.7	4.5	5.5	6.0
70.0	1.7	2.4	3.0	3.7	
75.0			1.7	2.2	
危険角度 (°)	40	41	41	45	60
フック種類	12t	12t	12t	12t	12t
フック質量 (t)	0.53	0.53	0.53	0.53	0.53
巻掛本数	1	1	1	1	1

HA 性能

50.0m ブーム +4.4m+47.0m ヘビーリフトジブ

オフセット	10°	20°	30°	45°	60°
作業半径 (m)	荷重 (ton)	荷重 (ton)	荷重 (ton)	荷重 (ton)	荷重 (ton)
26.0	5.0				
28.0	5.0				
30.0	5.0				
32.0	5.0				
34.0	5.0	5.0			
36.0	5.0	5.0			
38.0	5.0	5.0			
40.0	5.0	5.0	4.5		
42.0	5.0	5.0	4.4		
44.0	5.0	5.0	4.3		
46.0	5.0	4.9	4.2		
48.0	5.0	4.8	4.1	3.1	
50.0	5.0	4.7	4.0	3.0	
55.0	5.0	4.4	3.8	2.9	2.0
60.0	3.6	4.2	3.7	2.8	2.0
65.0	2.2	3.2	3.6	2.8	2.0
70.0		1.9	2.6	2.8	2.0
75.0			1.3	2.1	
危険角度 (°)	49	50	50	51	60
フック種類	12t	12t	12t	12t	12t
フック質量 (t)	0.53	0.53	0.53	0.53	0.53
巻掛本数	1	1	1	1	1

HA 性能

45.5m ブーム +4.4m+47.0m ヘビーリフトジブ

オフセット	10°	20°	30°	45°	60°
作業半径 (m)	荷重 (ton)	荷重 (ton)	荷重 (ton)	荷重 (ton)	荷重 (ton)
26.0	7.5				
28.0	7.5				
30.0	7.5				
32.0	7.5				
34.0	7.5	7.5			
36.0	7.5	7.5			
38.0	7.5	7.5			
40.0	7.5	7.5	7.5		
42.0	7.5	7.5	7.5		
44.0	7.5	7.5	7.5		
46.0	7.5	7.5	7.5		
48.0	7.5	7.5	7.5	6.7	
50.0	7.4	7.5	7.5	6.6	
55.0	5.5	6.7	7.5	6.4	4.9
60.0	3.9	4.9	5.9	6.2	4.9
65.0	2.5	3.4	4.3	5.3	4.9
70.0	1.3	2.1	2.8	3.7	
75.0			1.5	2.1	
危険角度 (°)	45	46	47	47	60
フック種類	12t	12t	12t	12t	12t
フック質量 (t)	0.53	0.53	0.53	0.53	0.53
巻掛本数	1	1	1	1	1

HA 性能

13.6m ブーム +4.4m+54.0m ヘビーリフトジブ

オフセット	10°	20°	30°	45°	60°
作業半径 (m)	荷重 (ton)	荷重 (ton)	荷重 (ton)	荷重 (ton)	荷重 (ton)
22.0	9.3				
24.0	9.3				
26.0	9.3				
28.0	9.3				
30.0	9.1	8.9			
32.0	9.1	8.8			
34.0	9.0	8.8			
36.0	8.9	8.6			
38.0	8.7	8.2	7.7		
40.0	8.4	7.9	7.4		
42.0	8.0	7.6	7.2		
44.0	7.7	7.3	6.9		
46.0	7.4	7.0	6.7	6.2	
48.0	7.1	6.8	6.5	6.1	
50.0	6.9	6.6	6.3	5.9	
55.0	6.3	6.1	5.9	5.4	4.9
60.0	5.8	5.6	5.3	4.9	4.6
65.0	5.2	5.0	4.8		
危険角度 (°)	10	20	30	45	60
フック種類	12t	12t	12t	12t	12t
フック質量 (t)	0.53	0.53	0.53	0.53	0.53
巻掛本数	1	1	1	1	1

HA 性能

22.7m ブーム +4.4m+54.0m ヘビーリフトジブ

オフセット	10°	20°	30°	45°	60°
作業半径 (m)	荷重 (ton)	荷重 (ton)	荷重 (ton)	荷重 (ton)	荷重 (ton)
24.0	9.3				
26.0	9.3				
28.0	9.3				
30.0	9.1				
32.0	9.1	8.9			
34.0	9.1	8.8			
36.0	9.0	8.7			
38.0	8.9	8.6	7.9		
40.0	8.8	8.3	7.7		
42.0	8.7	8.0	7.4		
44.0	8.4	7.7	7.2		
46.0	8.1	7.5	7.0		
48.0	7.8	7.2	6.8	6.2	
50.0	7.5	7.0	6.6	6.0	
55.0	6.9	6.5	6.2	5.7	5.1
60.0	6.3	6.1	5.8	5.2	4.8
65.0	4.9	5.6	5.3	4.8	4.6
70.0	3.7	4.2	4.7	4.6	
75.0	2.7	3.0	3.2		
危険角度 (°)	10	20	30	45	60
フック種類	12t	12t	12t	12t	12t
フック質量 (t)	0.53	0.53	0.53	0.53	0.53
巻掛本数	1	1	1	1	1

HA 性能

18.15m ブーム +4.4m+54.0m ヘビーリフトジブ

オフセット	10°	20°	30°	45°	60°
作業半径 (m)	荷重 (ton)	荷重 (ton)	荷重 (ton)	荷重 (ton)	荷重 (ton)
22.0	9.3				
24.0	9.3				
26.0	9.3				
28.0	9.3				
30.0	9.1	9.0			
32.0	9.1	9.0			
34.0	9.1	8.9			
36.0	8.9	8.8			
38.0	8.8	8.4	7.8		
40.0	8.7	8.1	7.6		
42.0	8.4	7.8	7.3		
44.0	8.0	7.5	7.1		
46.0	7.7	7.3	6.8		
48.0	7.5	7.0	6.6	6.1	
50.0	7.2	6.8	6.4	6.0	
55.0	6.6	6.3	6.0	5.5	5.0
60.0	6.1	5.9	5.6	5.0	4.7
65.0	5.6	5.3	5.0	4.7	
70.0	4.9	4.8	4.7		
危険角度 (°)	10	20	30	45	60
フック種類	12t	12t	12t	12t	12t
フック質量 (t)	0.53	0.53	0.53	0.53	0.53
巻掛本数	1	1	1	1	1

HA 性能

31.8m ブーム +4.4m+54.0m ヘビーリフトジブ

オフセット	10°	20°	30°	45°	60°
作業半径 (m)	荷重 (ton)	荷重 (ton)	荷重 (ton)	荷重 (ton)	荷重 (ton)
26.0	9.0				
28.0	9.0				
30.0	9.0				
32.0	9.0	8.9			
34.0	9.0	8.8			
36.0	9.0	8.7			
38.0	8.9	8.7			
40.0	8.8	8.7	7.9		
42.0	8.7	8.4	7.6		
44.0	8.7	8.1	7.4		
46.0	8.7	7.9	7.2		
48.0	8.4	7.6	7.0		
50.0	8.1	7.4	6.8	6.1	
55.0	7.0	6.9	6.4	5.8	
60.0	5.4	6.4	6.1	5.5	4.9
65.0	4.0	4.8	5.7	5.1	4.7
70.0	2.8	3.5	4.2	4.8	
75.0	1.8	2.3	2.9	3.4	
80.0			1.6		
危険角度 (°)	31	31	31	45	60
フック種類	12t	12t	12t	12t	12t
フック質量 (t)	0.53	0.53	0.53	0.53	0.53
巻掛本数	1	1	1	1	1

HA 性能

40.9m ブーム +4.4m+54.0m ヘビーリフトジブ

オフセット	10°	20°	30°	45°	60°
作業半径 (m)	荷重 (ton)	荷重 (ton)	荷重 (ton)	荷重 (ton)	荷重 (ton)
28.0	6.0				
30.0	6.0				
32.0	6.0				
34.0	6.0				
36.0	6.0	6.0			
38.0	6.0	6.0			
40.0	6.0	6.0			
42.0	6.0	6.0			
44.0	6.0	6.0	6.0		
46.0	6.0	6.0	6.0		
48.0	6.0	6.0	6.0		
50.0	6.0	6.0	6.0		
55.0	6.0	6.0	6.0	5.9	
60.0	4.6	5.8	6.0	5.7	4.9
65.0	3.2	4.2	5.2	5.3	4.7
70.0	2.0	2.9	3.7	4.8	4.6
75.0		1.7	2.4	3.3	
80.0				1.8	
危険角度 (°)	44	45	46	46	60
フック種類	12t	12t	12t	12t	12t
フック質量 (t)	0.53	0.53	0.53	0.53	0.53
巻掛本数	1	1	1	1	1

HA 性能

50.0m ブーム +4.4m+54.0m ヘビーリフトジブ

オフセット	10°	20°	30°	45°	60°
作業半径 (m)	荷重 (ton)	荷重 (ton)	荷重 (ton)	荷重 (ton)	荷重 (ton)
30.0	4.1				
32.0	4.1				
34.0	4.1				
36.0	4.1				
38.0	4.1	4.1			
40.0	4.1	4.1			
42.0	4.1	4.1			
44.0	4.1	4.0			
46.0	4.1	3.9	3.2		
48.0	4.1	3.8	3.1		
50.0	4.1	3.7	3.0		
55.0	4.0	3.4	2.8	2.0	
60.0	3.7	3.2	2.7	1.9	
65.0	2.5	3.1	2.6	1.8	
70.0		2.4	2.5	1.8	
75.0			2.0	1.8	
80.0				1.7	
危険角度 (°)	52	53	54	54	60
フック種類	12t	12t	12t	12t	12t
フック質量 (t)	0.53	0.53	0.53	0.53	0.53
巻掛本数	1	1	1	1	1

HA 性能

45.5m ブーム +4.4m+54.0m ヘビーリフトジブ

オフセット	10°	20°	30°	45°	60°
作業半径 (m)	荷重 (ton)	荷重 (ton)	荷重 (ton)	荷重 (ton)	荷重 (ton)
28.0	5.5				
30.0	5.5				
32.0	5.5				
34.0	5.5				
36.0	5.5	5.5			
38.0	5.5	5.5			
40.0	5.5	5.5			
42.0	5.5	5.5			
44.0	5.5	5.5	5.5		
46.0	5.5	5.5	5.5		
48.0	5.5	5.5	5.5		
50.0	5.5	5.5	5.5		
55.0	5.5	5.5	5.5	5.2	
60.0	4.3	5.5	5.5	5.0	3.7
65.0	2.9	3.9	5.0	4.8	3.6
70.0	1.7	2.6	3.5	4.7	3.6
75.0		1.4	2.2	3.2	3.6
80.0				1.8	
危険角度 (°)	48	49	50	51	60
フック種類	12t	12t	12t	12t	12t
フック質量 (t)	0.53	0.53	0.53	0.53	0.53
巻掛本数	1	1	1	1	1

HB 性能

13.6m ブーム +4.4m+13.0m ヘビーリフトジブ

オフセット	10°	20°	30°	45°	60°
作業半径 (m)	荷重 (ton)	荷重 (ton)	荷重 (ton)	荷重 (ton)	荷重 (ton)
7.0	84.0				
8.0	84.0	84.0			
9.0	84.0	80.1			
10.0	76.8	76.0	65.8		
11.0	68.8	70.5	63.2		
12.0	62.0	63.6	60.7	50.9	
14.0	51.5	52.7	53.9	48.1	34.2
16.0	42.5	43.4	44.3	45.4	33.3
18.0	35.3	36.0	36.7	37.5	32.7
20.0	29.9	30.4	30.9	31.5	
22.0	25.7	26.1	26.5	26.8	
24.0	22.3	22.6	22.9		
26.0	19.6	19.8	19.9		
28.0	17.3				
危険角度 (°)	10	20	30	45	60
フック種類	120t	120t	120t	120t	120t
フック質量 (t)	1.90	1.90	1.90	1.90	1.90
巻掛本数	8	8	8	8	8

HB 性能

22.7m ブーム +4.4m+13.0m ヘビーリフトジブ

オフセット	10°	20°	30°	45°	60°
作業半径 (m)	荷重 (ton)	荷重 (ton)	荷重 (ton)	荷重 (ton)	荷重 (ton)
8.0	64.0				
9.0	64.0				
10.0	64.0	64.0			
11.0	64.0	64.0			
12.0	58.4	60.7	62.8		
14.0	47.8	49.7	51.4	51.8	
16.0	39.2	40.6	41.9	43.6	38.6
18.0	32.1	33.2	34.3	35.6	36.5
20.0	26.7	27.7	28.6	29.6	30.3
22.0	22.6	23.4	24.1	24.9	25.4
24.0	19.2	19.9	20.5	21.1	
26.0	16.5	17.1	17.6	18.0	
28.0	14.3	14.7	15.1	15.4	
30.0	12.4	12.7	13.0		
32.0	10.7	11.0	11.2		
34.0	9.3	9.5	9.6		
36.0	8.1	8.2			
危険角度 (°)	10	20	30	45	60
フック種類	83t	83t	83t	83t	83t
フック質量 (t)	1.00	1.00	1.00	1.00	1.00
巻掛本数	6	6	6	6	6

HB 性能

18.15m ブーム +4.4m+13.0m ヘビーリフトジブ

オフセット	10°	20°	30°	45°	60°
作業半径 (m)	荷重 (ton)	荷重 (ton)	荷重 (ton)	荷重 (ton)	荷重 (ton)
7.0	77.0				
8.0	77.0				
9.0	77.0	77.0			
10.0	74.7	77.0			
11.0	66.6	68.8	65.2		
12.0	59.9	61.8	63.0		
14.0	49.3	50.9	52.4	50.6	
16.0	40.6	41.7	42.9	44.3	36.2
18.0	33.4	34.3	35.2	36.3	35.5
20.0	28.0	28.8	29.5	30.3	30.8
22.0	23.8	24.5	25.0	25.7	
24.0	20.5	21.0	21.5	21.9	
26.0	17.8	18.2	18.5	18.8	
28.0	15.5	15.8	16.0		
30.0	13.6	13.8	13.9		
32.0	12.0				
危険角度 (°)	10	20	30	45	60
フック種類	120t	120t	120t	120t	120t
フック質量 (t)	1.90	1.90	1.90	1.90	1.90
巻掛本数	8	8	8	8	8

HB 性能

31.8m ブーム +4.4m+13.0m ヘビーリフトジブ

オフセット	10°	20°	30°	45°	60°
作業半径 (m)	荷重 (ton)	荷重 (ton)	荷重 (ton)	荷重 (ton)	荷重 (ton)
10.0	45.0				
11.0	44.8	40.3			
12.0	44.1	39.8			
14.0	42.8	38.8	35.3		
16.0	39.1	38.0	34.7	30.2	
18.0	31.9	33.2	34.1	29.8	25.8
20.0	26.6	27.6	28.6	29.6	25.8
22.0	22.4	23.3	24.1	25.1	25.7
24.0	19.1	19.9	20.6	21.4	21.8
26.0	16.4	17.0	17.6	18.3	18.6
28.0	14.1	14.7	15.2	15.7	16.0
30.0	12.2	12.7	13.1	13.6	
32.0	10.5	11.0	11.3	11.7	
34.0	9.1	9.5	9.8	10.0	
36.0	7.9	8.2	8.4		
38.0	6.8	7.0	7.2		
40.0	5.7	6.0	6.1		
42.0	4.5	4.7			
44.0	3.5	3.6			
危険角度 (°)	10	20	30	45	60
フック種類	83t	83t	83t	83t	83t
フック質量 (t)	1.00	1.00	1.00	1.00	1.00
巻掛本数	4	4	4	4	4

HB 性能

13.6m ブーム +4.4m+22.0m ヘビーリフトジブ

オフセット	10°	20°	30°	45°	60°
作業半径 (m)	荷重 (ton)	荷重 (ton)	荷重 (ton)	荷重 (ton)	荷重 (ton)
10.0	54.0				
11.0	54.0				
12.0	54.0				
14.0	53.9	47.4			
16.0	44.8	43.1	38.0		
18.0	37.4	38.6	35.3		
20.0	31.8	32.8	33.0	28.1	
22.0	27.5	28.4	29.2	26.8	19.4
24.0	24.0	24.8	25.5	25.7	18.9
26.0	21.2	21.8	22.4	23.3	18.6
28.0	18.9	19.4	19.9	20.5	18.4
30.0	16.9	17.3	17.7	18.2	
32.0	15.2	15.5	15.8	16.1	
34.0	13.7	14.0	14.2		
36.0	12.5	12.6			
危険角度 (°)	10	20	30	45	60
フック種類	83t	83t	83t	83t	83t
フック質量 (t)	1.00	1.00	1.00	1.00	1.00
巻掛本数	6	6	6	6	6

HB 性能

22.7m ブーム +4.4m+22.0m ヘビーリフトジブ

オフセット	10°	20°	30°	45°	60°
作業半径 (m)	荷重 (ton)	荷重 (ton)	荷重 (ton)	荷重 (ton)	荷重 (ton)
11.0	45.0				
12.0	45.0				
14.0	45.0				
16.0	42.2	44.4			
18.0	34.8	36.6	38.4		
20.0	29.2	30.8	32.3		
22.0	24.9	26.3	27.6	29.4	
24.0	21.5	22.7	23.8	25.3	22.1
26.0	18.7	19.7	20.7	22.0	21.7
28.0	16.3	17.2	18.1	19.2	19.9
30.0	14.3	15.1	15.9	16.8	17.4
32.0	12.6	13.3	13.9	14.7	15.1
34.0	11.1	11.7	12.3	12.9	
36.0	9.9	10.4	10.8	11.3	
38.0	8.7	9.2	9.5	9.8	
40.0	7.7	8.1	8.3		
42.0	6.8	7.1	7.2		
44.0	6.0	6.2			
46.0	5.2				
危険角度 (°)	10	20	30	45	60
フック種類	83t	83t	83t	83t	83t
フック質量 (t)	1.00	1.00	1.00	1.00	1.00
巻掛本数	4	4	4	4	4

HB 性能

18.15m ブーム +4.4m+22.0m ヘビーリフトジブ

オフセット	10°	20°	30°	45°	60°
作業半径 (m)	荷重 (ton)	荷重 (ton)	荷重 (ton)	荷重 (ton)	荷重 (ton)
10.0	50.0				
11.0	50.0				
12.0	50.0				
14.0	50.0	49.4			
16.0	43.2	45.0			
18.0	35.8	37.4	36.4		
20.0	30.3	31.6	32.9		
22.0	26.0	27.1	28.2	28.2	
24.0	22.5	23.5	24.4	25.7	20.6
26.0	19.7	20.5	21.3	22.4	20.2
28.0	17.4	18.1	18.8	19.7	19.9
30.0	15.4	16.0	16.6	17.3	17.7
32.0	13.7	14.2	14.7	15.3	
34.0	12.2	12.7	13.1	13.5	
36.0	10.9	11.3	11.6		
38.0	9.8	10.1	10.3		
40.0	8.8	9.0			
42.0	7.9				
危険角度 (°)	10	20	30	45	60
フック種類	83t	83t	83t	83t	83t
フック質量 (t)	1.00	1.00	1.00	1.00	1.00
巻掛本数	6	6	6	6	6

HB 性能

31.8m ブーム +4.4m+22.0m ヘビーリフトジブ

オフセット	10°	20°	30°	45°	60°
作業半径 (m)	荷重 (ton)	荷重 (ton)	荷重 (ton)	荷重 (ton)	荷重 (ton)
14.0	30.0				
16.0	30.0	29.8			
18.0	30.0	28.9			
20.0	28.6	28.0	25.2		
22.0	24.3	25.8	24.6		
24.0	20.8	22.2	23.4	20.6	
26.0	18.0	19.2	20.3	20.3	17.0
28.0	15.7	16.7	17.7	19.0	16.9
30.0	13.7	14.7	15.5	16.6	16.9
32.0	12.0	12.9	13.6	14.6	15.2
34.0	10.6	11.3	12.0	12.8	13.3
36.0	9.3	9.9	10.5	11.3	11.6
38.0	8.1	8.7	9.3	9.9	
40.0	7.1	7.7	8.1	8.6	
42.0	6.2	6.7	7.1	7.5	
44.0	5.4	5.8	6.2	6.4	
46.0	4.4	4.9	5.3		
48.0	3.5	4.0	4.3		
50.0		3.1	3.2		
危険角度 (°)	24	24	30	45	60
フック種類	83t	83t	83t	83t	83t
フック質量 (t)	1.00	1.00	1.00	1.00	1.00
巻掛本数	4	4	4	4	4

HB 性能

40.9m ブーム +4.4m+22.0m ヘビーリフトジブ

オフセット	10°	20°	30°	45°	60°
作業半径 (m)	荷重 (ton)	荷重 (ton)	荷重 (ton)	荷重 (ton)	荷重 (ton)
16.0	20.0				
18.0	20.0				
20.0	20.0	20.0			
22.0	20.0	20.0	20.0		
24.0	20.0	20.0	20.0		
26.0	17.9	19.2	20.0	20.0	
28.0	15.5	16.7	17.7	19.1	20.0
30.0	13.6	14.6	15.5	16.7	17.6
32.0	11.9	12.8	13.6	14.7	15.4
34.0	10.4	11.2	12.0	12.9	13.5
36.0	9.1	9.9	10.5	11.4	11.9
38.0	8.0	8.6	9.3	10.0	10.4
40.0	6.9	7.6	8.1	8.8	9.1
42.0	6.0	6.6	7.1	7.7	
44.0	5.0	5.7	6.2	6.6	
46.0	4.1	4.8	5.3	5.7	
48.0	3.2	3.8	4.3	4.7	
50.0		2.9	3.3	3.7	
危険角度 (°)	40	41	41	45	60
フック種類	24t	24t	24t	24t	24t
フック質量 (t)	0.88	0.88	0.88	0.88	0.88
巻掛本数	2	2	2	2	2

HB 性能

50.0m ブーム +4.4m+22.0m ヘビーリフトジブ

オフセット	10°	20°	30°	45°	60°
作業半径 (m)	荷重 (ton)	荷重 (ton)	荷重 (ton)	荷重 (ton)	荷重 (ton)
18.0	11.0				
20.0	11.0				
22.0	11.0	11.0			
24.0	11.0	11.0	11.0		
26.0	11.0	11.0	11.0		
28.0	11.0	11.0	10.9	9.1	
30.0	11.0	11.0	10.8	9.1	7.5
32.0	11.0	11.0	10.6	9.0	7.5
34.0	10.0	10.9	10.5	9.0	7.5
36.0	8.7	9.6	10.3	8.9	7.5
38.0	7.6	8.4	9.1	8.9	7.5
40.0	6.6	7.3	7.9	8.7	7.5
42.0	5.6	6.3	6.9	7.6	7.5
44.0	4.5	5.4	6.0	6.6	6.9
46.0	3.6	4.4	5.1	5.7	
48.0	2.7	3.4	4.1	4.7	
50.0			3.1	3.7	
危険角度 (°)	50	50	51	51	60
フック種類	24t	24t	24t	24t	24t
フック質量 (t)	0.88	0.88	0.88	0.88	0.88
巻掛本数	2	2	2	2	2

HB 性能

45.5m ブーム +4.4m+22.0m ヘビーリフトジブ

オフセット	10°	20°	30°	45°	60°
作業半径 (m)	荷重 (ton)	荷重 (ton)	荷重 (ton)	荷重 (ton)	荷重 (ton)
16.0	16.0				
18.0	16.0				
20.0	16.0	16.0			
22.0	16.0	16.0			
24.0	16.0	16.0	16.0		
26.0	16.0	16.0	16.0		
28.0	15.4	16.0	16.0	15.6	
30.0	13.4	14.4	15.4	15.4	13.0
32.0	11.7	12.6	13.5	14.6	13.0
34.0	10.2	11.1	11.9	12.9	12.9
36.0	8.9	9.7	10.4	11.3	11.9
38.0	7.8	8.5	9.2	9.9	10.4
40.0	6.8	7.4	8.0	8.7	9.1
42.0	5.9	6.5	7.0	7.6	7.9
44.0	4.8	5.6	6.1	6.6	
46.0	3.8	4.6	5.2	5.7	
48.0	2.9	3.6	4.2	4.8	
50.0		2.7	3.2	3.7	
危険角度 (°)	46	46	47	47	60
フック種類	24t	24t	24t	24t	24t
フック質量 (t)	0.88	0.88	0.88	0.88	0.88
巻掛本数	2	2	2	2	2

HB 性能

13.6m ブーム +4.4m+31.0m ヘビーリフトジブ

オフセット	10°	20°	30°	45°	60°
作業半径 (m)	荷重 (ton)	荷重 (ton)	荷重 (ton)	荷重 (ton)	荷重 (ton)
14.0	35.0				
16.0	34.4				
18.0	34.4	33.8			
20.0	33.2	31.5			
22.0	28.7	29.1	26.1		
24.0	25.2	26.2	24.5		
26.0	22.3	23.2	23.1		
28.0	19.9	20.7	21.5	18.8	
30.0	17.9	18.6	19.3	18.0	
32.0	16.2	16.8	17.4	17.3	12.7
34.0	14.7	15.2	15.7	16.5	12.4
36.0	13.3	13.8	14.3	14.9	12.2
38.0	12.2	12.6	13.0	13.5	
40.0	11.2	11.5	11.8	12.2	
42.0	10.2	10.5	10.7		
44.0	9.4	9.6	9.7		
46.0	8.7				
危険角度 (°)	10	20	30	45	60
フック種類	83t	83t	83t	83t	83t
フック質量 (t)	1.00	1.00	1.00	1.00	1.00
巻掛本数	4	4	4	4	4

HB 性能

22.7m ブーム +4.4m+31.0m ヘビーリフトジブ

オフセット	10°	20°	30°	45°	60°
作業半径 (m)	荷重 (ton)	荷重 (ton)	荷重 (ton)	荷重 (ton)	荷重 (ton)
16.0	30.0				
18.0	30.0				
20.0	30.0	30.0			
22.0	26.4	28.2			
24.0	22.8	24.4	25.8		
26.0	20.0	21.4	22.8		
28.0	17.6	18.8	20.1		
30.0	15.5	16.7	17.8	19.3	
32.0	13.8	14.8	15.8	17.2	
34.0	12.3	13.2	14.1	15.3	14.5
36.0	11.0	11.8	12.6	13.7	14.2
38.0	9.8	10.5	11.3	12.2	12.9
40.0	8.8	9.4	10.1	10.9	11.4
42.0	7.8	8.4	9.0	9.7	
44.0	7.0	7.5	8.0	8.6	
46.0	6.3	6.7	7.1	7.6	
48.0	5.6	6.0	6.3		
50.0	5.0	5.3	5.5		
55.0	3.2				
危険角度 (°)	10	20	30	45	60
フック種類	83t	83t	83t	83t	83t
フック質量 (t)	1.00	1.00	1.00	1.00	1.00
巻掛本数	4	4	4	4	4

HB 性能

18.15m ブーム +4.4m+31.0m ヘビーリフトジブ

オフセット	10°	20°	30°	45°	60°
作業半径 (m)	荷重 (ton)	荷重 (ton)	荷重 (ton)	荷重 (ton)	荷重 (ton)
14.0	34.0				
16.0	34.0				
18.0	34.0	34.0			
20.0	31.9	32.8			
22.0	27.5	29.0	26.8		
24.0	23.9	25.3	25.2		
26.0	21.1	22.2	23.4		
28.0	18.7	19.7	20.7	19.8	
30.0	16.6	17.6	18.5	19.1	
32.0	14.9	15.7	16.5	17.7	13.9
34.0	13.4	14.1	14.8	15.9	13.6
36.0	12.1	12.7	13.4	14.2	13.4
38.0	10.9	11.5	12.0	12.8	13.2
40.0	9.9	10.4	10.9	11.5	
42.0	8.9	9.4	9.8	10.3	
44.0	8.1	8.5	8.8	9.2	
46.0	7.4	7.7	7.9		
48.0	6.7	6.9	7.0		
50.0	6.1				
危険角度 (°)	10	20	30	45	60
フック種類	83t	83t	83t	83t	83t
フック質量 (t)	1.00	1.00	1.00	1.00	1.00
巻掛本数	4	4	4	4	4

HB 性能

31.8m ブーム +4.4m+31.0m ヘビーリフトジブ

オフセット	10°	20°	30°	45°	60°
作業半径 (m)	荷重 (ton)	荷重 (ton)	荷重 (ton)	荷重 (ton)	荷重 (ton)
16.0	20.0				
18.0	20.0				
20.0	20.0				
22.0	20.0	20.0			
24.0	20.0	20.0			
26.0	19.6	20.0	19.4		
28.0	17.2	18.6	18.9		
30.0	15.1	16.4	17.7	15.6	
32.0	13.4	14.6	15.7	15.3	
34.0	11.9	12.9	13.9	15.1	12.4
36.0	10.5	11.5	12.4	13.7	12.3
38.0	9.4	10.3	11.1	12.2	12.3
40.0	8.3	9.1	9.9	10.9	11.6
42.0	7.4	8.1	8.8	9.7	10.3
44.0	6.6	7.2	7.9	8.6	9.1
46.0	5.8	6.4	7.0	7.6	8.0
48.0	5.1	5.7	6.2	6.7	
50.0	4.3	5.0	5.4	5.9	
55.0		3.0	3.4		
危険角度 (°)	33	33	34	45	60
フック種類	24t	24t	24t	24t	24t
フック質量 (t)	0.88	0.88	0.88	0.88	0.88
巻掛本数	2	2	2	2	2

HB 性能

40.9m ブーム +4.4m+31.0m ヘビーリフトジブ

オフセット	10°	20°	30°	45°	60°
作業半径 (m)	荷重 (ton)	荷重 (ton)	荷重 (ton)	荷重 (ton)	荷重 (ton)
18.0	14.0				
20.0	14.0				
22.0	14.0				
24.0	14.0	14.0			
26.0	14.0	14.0			
28.0	14.0	14.0	14.0		
30.0	14.0	14.0	14.0		
32.0	12.9	14.0	14.0		
34.0	11.4	12.5	13.6	14.0	
36.0	10.0	11.1	12.1	13.5	
38.0	8.9	9.9	10.8	12.0	13.0
40.0	7.8	8.7	9.6	10.7	11.5
42.0	6.9	7.7	8.5	9.5	10.2
44.0	6.1	6.8	7.6	8.5	9.1
46.0	5.3	6.0	6.7	7.5	8.0
48.0	4.4	5.3	5.9	6.6	7.0
50.0	3.5	4.4	5.1	5.8	6.1
55.0				3.7	
危険角度 (°)	46	47	47	48	60
フック種類	24t	24t	24t	24t	24t
フック質量 (t)	0.88	0.88	0.88	0.88	0.88
巻掛本数	2	2	2	2	2

HB 性能

50.0m ブーム +4.4m+31.0m ヘビーリフトジブ

オフセット	10°	20°	30°	45°	60°
作業半径 (m)	荷重 (ton)	荷重 (ton)	荷重 (ton)	荷重 (ton)	荷重 (ton)
20.0	9.0				
22.0	9.0				
24.0	9.0				
26.0	9.0	9.0			
28.0	9.0	9.0			
30.0	9.0	9.0	7.8		
32.0	9.0	8.8	7.7		
34.0	9.0	8.6	7.5		
36.0	9.0	8.4	7.4	6.0	
38.0	8.4	8.2	7.3	5.9	4.7
40.0	7.4	8.1	7.2	5.9	4.6
42.0	6.5	7.4	7.1	5.8	4.6
44.0	5.6	6.5	7.0	5.8	4.6
46.0	4.7	5.7	6.4	5.8	4.6
48.0	3.7	4.8	5.6	5.8	4.6
50.0		3.9	4.9	5.7	4.6
55.0				3.6	
危険角度 (°)	55	56	56	56	60
フック種類	24t	24t	24t	24t	24t
フック質量 (t)	0.88	0.88	0.88	0.88	0.88
巻掛本数	2	2	2	2	2

HB 性能

45.5m ブーム +4.4m+31.0m ヘビーリフトジブ

オフセット	10°	20°	30°	45°	60°
作業半径 (m)	荷重 (ton)	荷重 (ton)	荷重 (ton)	荷重 (ton)	荷重 (ton)
20.0	12.0				
22.0	12.0				
24.0	12.0	12.0			
26.0	12.0	12.0			
28.0	12.0	12.0			
30.0	12.0	12.0	12.0		
32.0	12.0	12.0	12.0		
34.0	11.1	12.0	12.0	11.1	
36.0	9.8	10.9	12.0	11.0	
38.0	8.6	9.7	10.6	10.9	8.9
40.0	7.6	8.6	9.5	10.6	8.9
42.0	6.7	7.6	8.4	9.5	8.8
44.0	5.8	6.7	7.4	8.4	8.8
46.0	4.9	5.8	6.5	7.4	8.0
48.0	4.0	5.1	5.7	6.5	7.0
50.0	3.2	4.2	5.0	5.7	6.1
55.0			2.9	3.7	
危険角度 (°)	50	51	51	52	60
フック種類	24t	24t	24t	24t	24t
フック質量 (t)	0.88	0.88	0.88	0.88	0.88
巻掛本数	2	2	2	2	2

HB 性能

13.6m ブーム +4.4m+40.0m ヘビーリフトジブ

オフセット	10°	20°	30°	45°	60°
作業半径 (m)	荷重 (ton)	荷重 (ton)	荷重 (ton)	荷重 (ton)	荷重 (ton)
16.0	12.0				
18.0	12.0				
20.0	12.0				
22.0	12.0	12.0			
24.0	12.0	12.0			
26.0	12.0	12.0			
28.0	12.0	12.0	12.0		
30.0	12.0	12.0	12.0		
32.0	12.0	12.0	12.0		
34.0	12.0	12.0	12.0		
36.0	12.0	12.0	12.0	11.8	
38.0	12.0	12.0	12.0	11.2	
40.0	12.0	12.0	11.9	10.7	9.4
42.0	11.2	11.7	11.3	10.2	9.2
44.0	10.3	10.7	10.7	9.8	9.0
46.0	9.6	9.9	10.3	9.5	8.9
48.0	8.8	9.2	9.5	9.2	
50.0	8.2	8.5	8.7	9.0	
55.0	6.8				
危険角度 (°)	10	20	30	45	60
フック種類	12t	12t	12t	12t	12t
フック質量 (t)	0.53	0.53	0.53	0.53	0.53
巻掛本数	1	1	1	1	1

HB 性能

22.7m ブーム +4.4m+40.0m ヘビーリフトジブ

オフセット	10°	20°	30°	45°	60°
作業半径 (m)	荷重 (ton)	荷重 (ton)	荷重 (ton)	荷重 (ton)	荷重 (ton)
18.0	12.0				
20.0	12.0				
22.0	12.0				
24.0	12.0	12.0			
26.0	12.0	12.0			
28.0	12.0	12.0			
30.0	12.0	12.0	12.0		
32.0	12.0	12.0	12.0		
34.0	12.0	12.0	12.0		
36.0	12.0	12.0	12.0	12.0	
38.0	11.2	12.0	12.0	11.7	
40.0	10.1	11.0	11.9	11.3	
42.0	9.1	10.0	10.8	10.8	9.7
44.0	8.3	9.0	9.8	10.5	9.5
46.0	7.5	8.2	8.9	9.8	9.3
48.0	6.8	7.4	8.0	8.8	9.1
50.0	6.1	6.7	7.3	8.0	8.4
55.0	4.7	5.2	5.5	6.0	
60.0	3.3	3.7	3.9		
危険角度 (°)	10	20	30	45	60
フック種類	12t	12t	12t	12t	12t
フック質量 (t)	0.53	0.53	0.53	0.53	0.53
巻掛本数	1	1	1	1	1

HB 性能

18.15m ブーム +4.4m+40.0m ヘビーリフトジブ

オフセット	10°	20°	30°	45°	60°
作業半径 (m)	荷重 (ton)	荷重 (ton)	荷重 (ton)	荷重 (ton)	荷重 (ton)
18.0	12.0				
20.0	12.0				
22.0	12.0				
24.0	12.0	12.0			
26.0	12.0	12.0			
28.0	12.0	12.0			
30.0	12.0	12.0	12.0		
32.0	12.0	12.0	12.0		
34.0	12.0	12.0	12.0		
36.0	12.0	12.0	12.0	12.0	
38.0	12.0	12.0	12.0	11.5	
40.0	11.0	11.8	12.0	11.0	9.9
42.0	10.1	10.8	11.4	10.6	9.6
44.0	9.2	9.8	10.4	10.2	9.3
46.0	8.5	9.0	9.5	9.8	9.2
48.0	7.8	8.2	8.7	9.3	9.0
50.0	7.1	7.5	7.9	8.5	
55.0	5.7	6.0	6.2		
60.0	4.5				
危険角度 (°)	10	20	30	45	60
フック種類	12t	12t	12t	12t	12t
フック質量 (t)	0.53	0.53	0.53	0.53	0.53
巻掛本数	1	1	1	1	1

HB 性能

31.8m ブーム +4.4m+40.0m ヘビーリフトジブ

オフセット	10°	20°	30°	45°	60°
作業半径 (m)	荷重 (ton)	荷重 (ton)	荷重 (ton)	荷重 (ton)	荷重 (ton)
20.0	12.0				
22.0	12.0				
24.0	12.0				
26.0	12.0	12.0			
28.0	12.0	12.0			
30.0	12.0	12.0			
32.0	12.0	12.0	12.0		
34.0	12.0	12.0	12.0		
36.0	11.7	12.0	12.0		
38.0	10.5	11.6	12.0	12.0	
40.0	9.5	10.5	11.5	11.7	
42.0	8.5	9.5	10.4	11.3	
44.0	7.6	8.5	9.4	10.6	9.5
46.0	6.9	7.7	8.5	9.6	9.4
48.0	6.2	6.9	7.7	8.6	9.3
50.0	5.5	6.2	6.9	7.8	8.4
55.0	3.9	4.7	5.2	5.9	6.2
60.0	2.4	3.0	3.6	4.2	
65.0		1.5	1.9		
危険角度 (°)	32	33	33	45	60
フック種類	12t	12t	12t	12t	12t
フック質量 (t)	0.53	0.53	0.53	0.53	0.53
巻掛本数	1	1	1	1	1

HB 性能

40.9m ブーム +4.4m+40.0m ヘビーリフトジブ

オフセット	10°	20°	30°	45°	60°
作業半径 (m)	荷重 (ton)	荷重 (ton)	荷重 (ton)	荷重 (ton)	荷重 (ton)
22.0	11.0				
24.0	11.0				
26.0	11.0				
28.0	11.0	11.0			
30.0	11.0	11.0			
32.0	11.0	11.0			
34.0	11.0	11.0	11.0		
36.0	11.0	11.0	11.0		
38.0	10.0	11.0	11.0		
40.0	8.9	10.1	11.0		
42.0	8.0	9.1	10.1	11.0	
44.0	7.1	8.1	9.1	10.4	
46.0	6.3	7.3	8.2	9.4	9.6
48.0	5.6	6.5	7.3	8.5	9.3
50.0	5.0	5.8	6.6	7.6	8.4
55.0	3.1	4.1	4.9	5.7	6.3
60.0	1.6	2.4	3.2	4.1	
65.0			1.6	2.2	
危険角度 (°)	45	46	47	47	60
フック種類	12t	12t	12t	12t	12t
フック質量 (t)	0.53	0.53	0.53	0.53	0.53
巻掛本数	1	1	1	1	1

HB 性能

50.0m ブーム +4.4m+40.0m ヘビーリフトジブ

オフセット	10°	20°	30°	45°	60°
作業半径 (m)	荷重 (ton)	荷重 (ton)	荷重 (ton)	荷重 (ton)	荷重 (ton)
24.0	7.0				
26.0	7.0				
28.0	7.0				
30.0	7.0	7.0			
32.0	7.0	7.0			
34.0	7.0	7.0			
36.0	7.0	6.8	5.9		
38.0	7.0	6.7	5.8		
40.0	7.0	6.5	5.6		
42.0	7.0	6.4	5.5		
44.0	6.7	6.2	5.4	4.3	
46.0	5.9	6.1	5.3	4.2	
48.0	5.2	6.0	5.2	4.2	3.1
50.0	4.3	5.4	5.2	4.1	3.1
55.0		3.6	4.6	4.1	3.1
60.0			2.8	3.9	3.1
65.0				2.1	
危険角度 (°)	56	57	57	57	60
フック種類	12t	12t	12t	12t	12t
フック質量 (t)	0.53	0.53	0.53	0.53	0.53
巻掛本数	1	1	1	1	1

HB 性能

45.5m ブーム +4.4m+40.0m ヘビーリフトジブ

オフセット	10°	20°	30°	45°	60°
作業半径 (m)	荷重 (ton)	荷重 (ton)	荷重 (ton)	荷重 (ton)	荷重 (ton)
24.0	10.0				
26.0	10.0				
28.0	10.0				
30.0	10.0	10.0			
32.0	10.0	10.0			
34.0	10.0	10.0			
36.0	10.0	10.0	10.0		
38.0	9.8	10.0	10.0		
40.0	8.7	9.9	10.0		
42.0	7.7	8.9	10.0	8.5	
44.0	6.9	7.9	8.9	8.3	
46.0	6.1	7.1	8.0	8.2	6.6
48.0	5.4	6.3	7.2	8.1	6.5
50.0	4.6	5.6	6.4	7.5	6.5
55.0	2.8	3.9	4.8	5.7	6.2
60.0		2.2	3.0	4.0	4.5
65.0				2.2	
危険角度 (°)	51	52	52	53	60
フック種類	12t	12t	12t	12t	12t
フック質量 (t)	0.53	0.53	0.53	0.53	0.53
巻掛本数	1	1	1	1	1

HB 性能

13.6m ブーム +4.4m+47.0m ヘビーリフトジブ

オフセット	10°	20°	30°	45°	60°
作業半径 (m)	荷重 (ton)	荷重 (ton)	荷重 (ton)	荷重 (ton)	荷重 (ton)
18.0	12.0				
20.0	12.0				
22.0	12.0				
24.0	12.0				
26.0	12.0	12.0			
28.0	12.0	12.0			
30.0	12.0	12.0			
32.0	12.0	12.0	12.0		
34.0	12.0	12.0	12.0		
36.0	12.0	12.0	11.7		
38.0	12.0	12.0	10.9		
40.0	12.0	11.2	10.3		
42.0	11.5	10.5	9.7	8.6	
44.0	10.6	9.9	9.2	8.2	
46.0	9.8	9.4	8.7	7.8	7.1
48.0	9.1	8.8	8.2	7.5	6.9
50.0	8.5	8.4	7.9	7.2	6.7
55.0	7.1	7.4	7.1	6.6	
60.0	5.9	6.1	6.2		
危険角度 (°)	10	20	30	45	60
フック種類	12t	12t	12t	12t	12t
フック質量 (t)	0.53	0.53	0.53	0.53	0.53
巻掛本数	1	1	1	1	1

HB 性能

22.7m ブーム +4.4m+47.0m ヘビーリフトジブ

オフセット	10°	20°	30°	45°	60°
作業半径 (m)	荷重 (ton)	荷重 (ton)	荷重 (ton)	荷重 (ton)	荷重 (ton)
20.0	12.0				
22.0	12.0				
24.0	12.0				
26.0	12.0				
28.0	12.0	12.0			
30.0	12.0	12.0			
32.0	12.0	12.0			
34.0	12.0	12.0	12.0		
36.0	12.0	12.0	12.0		
38.0	11.7	12.0	11.7		
40.0	10.6	11.6	11.1		
42.0	9.6	10.6	10.5	8.9	
44.0	8.8	9.6	10.0	8.6	
46.0	8.0	8.8	9.5	8.2	
48.0	7.2	8.0	8.8	7.9	7.1
50.0	6.6	7.3	8.0	7.6	6.9
55.0	5.2	5.8	6.3	7.0	6.5
60.0	3.9	4.5	4.9	5.4	
65.0	2.6	3.1	3.5		
70.0	1.4	1.6			
危険角度 (°)	14	20	30	45	60
フック種類	12t	12t	12t	12t	12t
フック質量 (t)	0.53	0.53	0.53	0.53	0.53
巻掛本数	1	1	1	1	1

HB 性能

18.15m ブーム +4.4m+47.0m ヘビーリフトジブ

オフセット	10°	20°	30°	45°	60°
作業半径 (m)	荷重 (ton)	荷重 (ton)	荷重 (ton)	荷重 (ton)	荷重 (ton)
20.0	12.0				
22.0	12.0				
24.0	12.0				
26.0	12.0	12.0			
28.0	12.0	12.0			
30.0	12.0	12.0			
32.0	12.0	12.0			
34.0	12.0	12.0	12.0		
36.0	12.0	12.0	12.0		
38.0	12.0	12.0	11.3		
40.0	11.5	12.0	10.7		
42.0	10.5	11.2	10.1	8.8	
44.0	9.6	10.3	9.6	8.4	
46.0	8.8	9.5	9.1	8.0	
48.0	8.1	8.7	8.7	7.7	7.0
50.0	7.5	8.0	8.3	7.4	6.8
55.0	6.1	6.5	6.9	6.8	6.5
60.0	4.9	5.2	5.5	5.8	
65.0	3.9	4.1			
危険角度 (°)	10	20	30	45	60
フック種類	12t	12t	12t	12t	12t
フック質量 (t)	0.53	0.53	0.53	0.53	0.53
巻掛本数	1	1	1	1	1

HB 性能

31.8m ブーム +4.4m+47.0m ヘビーリフトジブ

オフセット	10°	20°	30°	45°	60°
作業半径 (m)	荷重 (ton)	荷重 (ton)	荷重 (ton)	荷重 (ton)	荷重 (ton)
22.0	12.0				
24.0	12.0				
26.0	12.0				
28.0	12.0				
30.0	12.0	12.0			
32.0	12.0	12.0			
34.0	12.0	12.0			
36.0	12.0	12.0	12.0		
38.0	11.0	12.0	12.0		
40.0	9.9	11.1	11.8		
42.0	9.0	10.1	11.2		
44.0	8.1	9.1	10.2	8.8	
46.0	7.3	8.3	9.2	8.5	
48.0	6.6	7.5	8.4	8.2	
50.0	5.9	6.8	7.6	8.0	7.0
55.0	4.5	5.2	5.9	6.9	6.7
60.0	3.0	3.8	4.5	5.2	5.7
65.0	1.7	2.4	3.0	3.8	
70.0			1.6	2.0	
危険角度 (°)	38	39	40	45	60
フック種類	12t	12t	12t	12t	12t
フック質量 (t)	0.53	0.53	0.53	0.53	0.53
巻掛本数	1	1	1	1	1

HB 性能

40.9m ブーム +4.4m+47.0m ヘビーリフトジブ

オフセット	10°	20°	30°	45°	60°
作業半径 (m)	荷重 (ton)	荷重 (ton)	荷重 (ton)	荷重 (ton)	荷重 (ton)
26.0	8.0				
28.0	8.0				
30.0	8.0				
32.0	8.0	8.0			
34.0	8.0	8.0			
36.0	8.0	8.0			
38.0	8.0	8.0			
40.0	8.0	8.0	8.0		
42.0	8.0	8.0	8.0		
44.0	7.5	8.0	8.0		
46.0	6.8	7.9	8.0		
48.0	6.0	7.1	8.0	8.0	
50.0	5.4	6.4	7.3	8.0	
55.0	3.7	4.8	5.6	6.7	6.8
60.0	2.2	3.2	4.2	5.1	5.7
65.0		1.7	2.6	3.6	4.1
70.0				1.9	
危険角度 (°)	49	50	51	51	60
フック種類	12t	12t	12t	12t	12t
フック質量 (t)	0.53	0.53	0.53	0.53	0.53
巻掛本数	1	1	1	1	1

HB 性能

50.0m ブーム +4.4m+47.0m ヘビーリフトジブ

オフセット	10°	20°	30°	45°	60°
作業半径 (m)	荷重 (ton)	荷重 (ton)	荷重 (ton)	荷重 (ton)	荷重 (ton)
26.0	5.0				
28.0	5.0				
30.0	5.0				
32.0	5.0				
34.0	5.0	5.0			
36.0	5.0	5.0			
38.0	5.0	5.0			
40.0	5.0	5.0	4.5		
42.0	5.0	5.0	4.4		
44.0	5.0	5.0	4.3		
46.0	5.0	4.9	4.2		
48.0	5.0	4.8	4.1	3.1	
50.0	4.9	4.7	4.0	3.0	
55.0		4.4	3.8	2.9	2.0
60.0		2.7	3.7	2.8	2.0
65.0				2.8	2.0
70.0					2.0
危険角度 (°)	59	59	60	60	60
フック種類	12t	12t	12t	12t	12t
フック質量 (t)	0.53	0.53	0.53	0.53	0.53
巻掛本数	1	1	1	1	1

HB 性能

45.5m ブーム +4.4m+47.0m ヘビーリフトジブ

オフセット	10°	20°	30°	45°	60°
作業半径 (m)	荷重 (ton)	荷重 (ton)	荷重 (ton)	荷重 (ton)	荷重 (ton)
26.0	7.5				
28.0	7.5				
30.0	7.5				
32.0	7.5				
34.0	7.5	7.5			
36.0	7.5	7.5			
38.0	7.5	7.5			
40.0	7.5	7.5	7.5		
42.0	7.5	7.5	7.5		
44.0	7.3	7.5	7.5		
46.0	6.5	7.5	7.5		
48.0	5.8	6.9	7.5	6.7	
50.0	5.1	6.2	7.1	6.6	
55.0	3.3	4.6	5.4	6.4	4.9
60.0		2.9	4.0	5.0	4.9
65.0			2.4	3.5	4.1
70.0				1.8	
危険角度 (°)	54	55	56	56	60
フック種類	12t	12t	12t	12t	12t
フック質量 (t)	0.53	0.53	0.53	0.53	0.53
巻掛本数	1	1	1	1	1

HB 性能

13.6m ブーム +4.4m+54.0m ヘビーリフトジブ

オフセット	10°	20°	30°	45°	60°
作業半径 (m)	荷重 (ton)	荷重 (ton)	荷重 (ton)	荷重 (ton)	荷重 (ton)
22.0	9.3				
24.0	9.3				
26.0	9.3				
28.0	9.3				
30.0	9.1	8.9			
32.0	9.1	8.8			
34.0	9.0	8.8			
36.0	8.9	8.6			
38.0	8.7	8.2	7.7		
40.0	8.4	7.9	7.4		
42.0	8.0	7.6	7.2		
44.0	7.7	7.3	6.9		
46.0	7.4	7.0	6.7	6.2	
48.0	7.1	6.8	6.5	6.1	
50.0	6.9	6.6	6.3	5.9	
55.0	6.3	6.1	5.9	5.4	4.9
60.0	5.8	5.6	5.3	4.9	4.6
65.0	5.1	5.0	4.8		
危険角度 (°)	10	20	30	45	60
フック種類	12t	12t	12t	12t	12t
フック質量 (t)	0.53	0.53	0.53	0.53	0.53
巻掛本数	1	1	1	1	1

HB 性能

22.7m ブーム +4.4m+54.0m ヘビーリフトジブ

オフセット	10°	20°	30°	45°	60°
作業半径 (m)	荷重 (ton)	荷重 (ton)	荷重 (ton)	荷重 (ton)	荷重 (ton)
24.0	9.3				
26.0	9.3				
28.0	9.3				
30.0	9.1				
32.0	9.1	8.9			
34.0	9.1	8.8			
36.0	9.0	8.7			
38.0	8.9	8.6	7.9		
40.0	8.8	8.3	7.7		
42.0	8.7	8.0	7.4		
44.0	8.4	7.7	7.2		
46.0	8.1	7.5	7.0		
48.0	7.6	7.2	6.8	6.2	
50.0	6.9	7.0	6.6	6.0	
55.0	5.5	6.2	6.2	5.7	5.1
60.0	4.3	4.9	5.5	5.2	4.8
65.0	3.1	3.8	4.3	4.8	4.6
70.0	2.0	2.5	3.0	3.5	
75.0		1.3	1.5		
危険角度 (°)	24	24	30	45	60
フック種類	12t	12t	12t	12t	12t
フック質量 (t)	0.53	0.53	0.53	0.53	0.53
巻掛本数	1	1	1	1	1

HB 性能

18.15m ブーム +4.4m+54.0m ヘビーリフトジブ

オフセット	10°	20°	30°	45°	60°
作業半径 (m)	荷重 (ton)	荷重 (ton)	荷重 (ton)	荷重 (ton)	荷重 (ton)
22.0	9.3				
24.0	9.3				
26.0	9.3				
28.0	9.3				
30.0	9.1	9.0			
32.0	9.1	9.0			
34.0	9.1	8.9			
36.0	8.9	8.8			
38.0	8.8	8.4	7.8		
40.0	8.7	8.1	7.6		
42.0	8.4	7.8	7.3		
44.0	8.0	7.5	7.1		
46.0	7.7	7.3	6.8		
48.0	7.5	7.0	6.6	6.1	
50.0	7.2	6.8	6.4	6.0	
55.0	6.3	6.3	6.0	5.5	5.0
60.0	5.2	5.6	5.6	5.0	4.7
65.0	4.2	4.5	4.9	4.7	
70.0	3.2	3.5	3.8		
危険角度 (°)	10	20	30	45	60
フック種類	12t	12t	12t	12t	12t
フック質量 (t)	0.53	0.53	0.53	0.53	0.53
巻掛本数	1	1	1	1	1

HB 性能

31.8m ブーム +4.4m+54.0m ヘビーリフトジブ

オフセット	10°	20°	30°	45°	60°
作業半径 (m)	荷重 (ton)	荷重 (ton)	荷重 (ton)	荷重 (ton)	荷重 (ton)
26.0	9.0				
28.0	9.0				
30.0	9.0				
32.0	9.0	8.9			
34.0	9.0	8.8			
36.0	9.0	8.7			
38.0	8.9	8.7			
40.0	8.8	8.7	7.9		
42.0	8.7	8.4	7.6		
44.0	8.5	8.1	7.4		
46.0	7.7	7.9	7.2		
48.0	6.9	7.6	7.0		
50.0	6.3	7.2	6.8	6.1	
55.0	4.8	5.7	6.4	5.8	
60.0	3.4	4.4	5.1	5.5	4.9
65.0	2.1	3.0	3.9	4.7	4.7
70.0		1.7	2.4	3.3	
75.0				1.7	
危険角度 (°)	45	45	45	45	60
フック種類	12t	12t	12t	12t	12t
フック質量 (t)	0.53	0.53	0.53	0.53	0.53
巻掛本数	1	1	1	1	1

HB 性能

40.9m ブーム +4.4m+54.0m ヘビーリフトジブ

オフセット	10°	20°	30°	45°	60°
作業半径 (m)	荷重 (ton)	荷重 (ton)	荷重 (ton)	荷重 (ton)	荷重 (ton)
28.0	6.0				
30.0	6.0				
32.0	6.0				
34.0	6.0				
36.0	6.0	6.0			
38.0	6.0	6.0			
40.0	6.0	6.0			
42.0	6.0	6.0			
44.0	6.0	6.0	6.0		
46.0	6.0	6.0	6.0		
48.0	6.0	6.0	6.0		
50.0	5.7	6.0	6.0		
55.0	4.2	5.2	6.0	5.9	
60.0	2.6	3.8	4.7	5.7	4.9
65.0		2.4	3.4	4.5	4.7
70.0			1.9	3.1	3.7
75.0				1.6	
危険角度 (°)	53	54	55	55	60
フック種類	12t	12t	12t	12t	12t
フック質量 (t)	0.53	0.53	0.53	0.53	0.53
巻掛本数	1	1	1	1	1

HB 性能

50.0m ブーム +4.4m+54.0m ヘビーリフトジブ

オフセット	10°	20°	30°	45°	60°
作業半径 (m)	荷重 (ton)	荷重 (ton)	荷重 (ton)	荷重 (ton)	荷重 (ton)
30.0	4.1				
32.0	4.1				
34.0	4.1				
36.0	4.1				
38.0	4.1	4.1			
40.0	4.1	4.1			
42.0	4.1	4.1			
44.0	4.1	4.0			
46.0	4.1	3.9	3.2		
48.0	4.1	3.8	3.1		
50.0	4.1	3.7	3.0		
55.0	3.5	3.4	2.8	2.0	
60.0		3.2	2.7	1.9	
65.0			2.6	1.8	
70.0				1.8	
危険角度 (°)	61	62	63	64	64
フック種類	12t	12t	12t	12t	12t
フック質量 (t)	0.53	0.53	0.53	0.53	0.53
巻掛本数	1	1	1	1	1

HB 性能

45.5m ブーム +4.4m+54.0m ヘビーリフトジブ

オフセット	10°	20°	30°	45°	60°
作業半径 (m)	荷重 (ton)	荷重 (ton)	荷重 (ton)	荷重 (ton)	荷重 (ton)
28.0	5.5				
30.0	5.5				
32.0	5.5				
34.0	5.5				
36.0	5.5	5.5			
38.0	5.5	5.5			
40.0	5.5	5.5			
42.0	5.5	5.5			
44.0	5.5	5.5	5.5		
46.0	5.5	5.5	5.5		
48.0	5.5	5.5	5.5		
50.0	5.5	5.5	5.5		
55.0	3.8	5.0	5.5	5.2	
60.0		3.5	4.6	5.0	3.7
65.0			3.1	4.4	3.6
70.0				2.9	3.6
75.0					2.0
危険角度 (°)	58	59	59	60	60
フック種類	12t	12t	12t	12t	12t
フック質量 (t)	0.53	0.53	0.53	0.53	0.53
巻掛本数	1	1	1	1	1

HC性能

13.6mブーム+4.4m+13mヘビーリフトジブ

オフセット	10°	20°	30°	45°	60°
作業半径 (m)	荷重 (ton)	荷重 (ton)	荷重 (ton)	荷重 (ton)	荷重 (ton)
7.0	84.0				
8.0	84.0	84.0			
9.0	84.0	80.1			
10.0	76.8	76.0	65.8		
11.0	68.8	70.5	63.2		
12.0	62.0	63.6	60.7	50.9	
14.0	51.5	52.7	53.9	48.1	34.2
16.0	42.5	43.4	44.3	45.4	33.3
18.0	35.3	36.0	36.7	37.5	32.7
20.0	29.9	30.4	30.9	31.5	
22.0	25.7	26.1	26.5	26.8	
24.0	22.3	22.6	22.9		
26.0	19.6	19.8	19.9		
28.0	17.3				
掛数	8	8	8	8	8
危険角度 (°)	10	20	30	45	60
フック種類	150t	150t	150t	150t	150t
フック質量 (t)	1.86	1.86	1.86	1.86	1.86

HC性能

22.7mブーム+4.4m+13mヘビーリフトジブ

オフセット	10°	20°	30°	45°	60°
作業半径 (m)	荷重 (ton)	荷重 (ton)	荷重 (ton)	荷重 (ton)	荷重 (ton)
8.0	64.0				
9.0	64.0				
10.0	64.0	64.0			
11.0	64.0	64.0			
12.0	58.4	60.7	62.8		
14.0	47.8	49.7	51.4	51.8	
16.0	39.2	40.6	41.9	43.6	38.6
18.0	32.1	33.2	34.3	35.6	36.5
20.0	26.7	27.7	28.6	29.6	30.3
22.0	22.6	23.4	24.1	24.9	25.4
24.0	19.2	19.9	20.5	21.1	
26.0	16.5	17.1	17.6	18.0	
28.0	14.3	14.7	15.1	15.4	
30.0	12.4	12.7	13.0		
32.0	10.7	11.0	11.2		
34.0	9.3	9.5	9.6		
36.0	8.1	8.2			
掛数	6	6	6	6	6
危険角度 (°)	10	20	30	45	60
フック種類	83t	83t	83t	83t	83t
フック質量 (t)	1.00	1.00	1.00	1.00	1.00

HC性能

18.15mブーム+4.4m+13mヘビーリフトジブ

オフセット	10°	20°	30°	45°	60°
作業半径 (m)	荷重 (ton)	荷重 (ton)	荷重 (ton)	荷重 (ton)	荷重 (ton)
7.0	77.0				
8.0	77.0				
9.0	77.0	77.0			
10.0	74.7	77.0			
11.0	66.6	68.8	65.2		
12.0	59.9	61.8	63.0		
14.0	49.3	50.9	52.4	50.6	
16.0	40.6	41.7	42.9	44.3	36.2
18.0	33.4	34.3	35.2	36.3	35.5
20.0	28.0	28.8	29.5	30.3	30.8
22.0	23.8	24.5	25.0	25.7	
24.0	20.5	21.0	21.5	21.9	
26.0	17.8	18.2	18.5	18.8	
28.0	15.5	15.8	16.0		
30.0	13.6	13.8	13.9		
32.0	12.0				
掛数	8	8	8	8	8
危険角度 (°)	10	20	30	45	60
フック種類	150t	150t	150t	150t	150t
フック質量 (t)	1.86	1.86	1.86	1.86	1.86

HC性能

31.8mブーム+4.4m+13mヘビーリフトジブ

オフセット	10°	20°	30°	45°	60°
作業半径 (m)	荷重 (ton)	荷重 (ton)	荷重 (ton)	荷重 (ton)	荷重 (ton)
10.0	45.0				
11.0	44.8	40.3			
12.0	44.1	39.8			
14.0	42.8	38.8	35.3		
16.0	39.1	38.0	34.7	30.2	
18.0	31.9	33.2	34.1	29.8	25.8
20.0	26.6	27.6	28.6	29.6	25.8
22.0	22.4	23.3	24.1	25.1	25.7
24.0	19.1	19.9	20.6	21.4	21.8
26.0	16.4	17.0	17.6	18.3	18.6
28.0	14.1	14.7	15.2	15.7	16.0
30.0	12.2	12.7	13.1	13.6	
32.0	10.5	11.0	11.3	11.7	
34.0	9.1	9.5	9.8	10.0	
36.0	7.9	8.2	8.4		
38.0	6.8	7.0	7.2		
40.0	5.7	6.0	6.1		
42.0	4.5	4.7			
44.0	3.5	3.6			
掛数	4	4	4	4	4
危険角度 (°)	10	20	30	45	60
フック種類	83t	83t	83t	83t	83t
フック質量 (t)	1.00	1.00	1.00	1.00	1.00

HC性能

13.6mブーム+4.4m+22mヘビーリフトジブ

オフセット	10°	20°	30°	45°	60°
作業半径 (m)	荷重 (ton)	荷重 (ton)	荷重 (ton)	荷重 (ton)	荷重 (ton)
10.0	54.0				
11.0	54.0				
12.0	54.0				
14.0	53.9	47.4			
16.0	44.8	43.1	38.0		
18.0	37.4	38.6	35.3		
20.0	31.8	32.8	33.0	28.1	
22.0	27.5	28.4	29.2	26.8	19.4
24.0	24.0	24.8	25.5	25.7	18.9
26.0	21.2	21.8	22.4	23.3	18.6
28.0	18.9	19.4	19.9	20.5	18.4
30.0	16.9	17.3	17.7	18.2	
32.0	15.2	15.5	15.8	16.1	
34.0	13.7	14.0	14.2		
36.0	12.5	12.6			
掛数	6	6	6	6	6
危険角度 (°)	10	20	30	45	60
フック種類	83t	83t	83t	83t	83t
フック質量 (t)	1.00	1.00	1.00	1.00	1.00

HC性能

22.7mブーム+4.4m+22mヘビーリフトジブ

オフセット	10°	20°	30°	45°	60°
作業半径 (m)	荷重 (ton)	荷重 (ton)	荷重 (ton)	荷重 (ton)	荷重 (ton)
11.0	45.0				
12.0	45.0				
14.0	45.0				
16.0	42.2	44.4			
18.0	34.8	36.6	38.4		
20.0	29.2	30.8	32.3		
22.0	24.9	26.3	27.6	29.4	
24.0	21.5	22.7	23.8	25.3	22.1
26.0	18.7	19.7	20.7	22.0	21.7
28.0	16.3	17.2	18.1	19.2	19.9
30.0	14.3	15.1	15.9	16.8	17.4
32.0	12.6	13.3	13.9	14.7	15.1
34.0	11.1	11.7	12.3	12.9	
36.0	9.9	10.4	10.8	11.3	
38.0	8.7	9.2	9.5	9.8	
40.0	7.7	8.1	8.3		
42.0	6.8	7.1	7.2		
44.0	6.0	6.2			
46.0	5.2				
掛数	4	4	4	4	4
危険角度 (°)	10	20	30	45	60
フック種類	83t	83t	83t	83t	83t
フック質量 (t)	1.00	1.00	1.00	1.00	1.00

HC性能

18.15mブーム+4.4m+22mヘビーリフトジブ

オフセット	10°	20°	30°	45°	60°
作業半径 (m)	荷重 (ton)	荷重 (ton)	荷重 (ton)	荷重 (ton)	荷重 (ton)
10.0	50.0				
11.0	50.0				
12.0	50.0				
14.0	50.0	49.4			
16.0	43.2	45.0			
18.0	35.8	37.4	36.4		
20.0	30.3	31.6	32.9		
22.0	26.0	27.1	28.2	28.2	
24.0	22.5	23.5	24.4	25.7	20.6
26.0	19.7	20.5	21.3	22.4	20.2
28.0	17.4	18.1	18.8	19.7	19.9
30.0	15.4	16.0	16.6	17.3	17.7
32.0	13.7	14.2	14.7	15.3	
34.0	12.2	12.7	13.1	13.5	
36.0	10.9	11.3	11.6		
38.0	9.8	10.1	10.3		
40.0	8.8	9.0			
42.0	7.9				
掛数	6	6	6	6	6
危険角度 (°)	10	20	30	45	60
フック種類	83t	83t	83t	83t	83t
フック質量 (t)	1.00	1.00	1.00	1.00	1.00

HC性能

31.8mブーム+4.4m+22mヘビーリフトジブ

オフセット	10°	20°	30°	45°	60°
作業半径 (m)	荷重 (ton)	荷重 (ton)	荷重 (ton)	荷重 (ton)	荷重 (ton)
14.0	30.0				
16.0	30.0	29.8			
18.0	30.0	28.9			
20.0	28.6	28.0	25.2		
22.0	24.3	25.8	24.6		
24.0	20.8	22.2	23.4	20.6	
26.0	18.0	19.2	20.3	20.3	17.0
28.0	15.7	16.7	17.7	19.0	16.9
30.0	13.7	14.7	15.5	16.6	16.9
32.0	12.0	12.9	13.6	14.6	15.2
34.0	10.6	11.3	12.0	12.8	13.3
36.0	9.3	9.9	10.5	11.3	11.6
38.0	8.1	8.7	9.3	9.9	
40.0	7.1	7.7	8.1	8.6	
42.0	6.2	6.7	7.1	7.5	
44.0	5.4	5.8	6.2	6.4	
46.0	4.4	4.9	5.3		
48.0	3.5	4.0	4.3		
50.0		3.1	3.2		
掛数	4	4	4	4	4
危険角度 (°)	24	24	30	45	60
フック種類	83t	83t	83t	83t	83t
フック質量 (t)	1.00	1.00	1.00	1.00	1.00

HC性能

40.9mブーム+4.4m+22mヘビーリフトジブ

オフセット	10°	20°	30°	45°	60°
作業半径 (m)	荷重 (ton)	荷重 (ton)	荷重 (ton)	荷重 (ton)	荷重 (ton)
16.0	20.0				
18.0	20.0				
20.0	20.0	20.0			
22.0	20.0	20.0	20.0		
24.0	20.0	20.0	20.0		
26.0	17.9	19.2	20.0	20.0	
28.0	15.5	16.7	17.7	19.1	20.0
30.0	13.6	14.6	15.5	16.7	17.6
32.0	11.9	12.8	13.6	14.7	15.4
34.0	10.4	11.2	12.0	12.9	13.5
36.0	9.1	9.9	10.5	11.4	11.9
38.0	8.0	8.6	9.3	10.0	10.4
40.0	6.9	7.6	8.1	8.8	9.1
42.0	6.0	6.6	7.1	7.7	
44.0	5.0	5.7	6.2	6.6	
46.0	4.1	4.8	5.3	5.7	
48.0	3.2	3.8	4.3	4.7	
50.0		2.9	3.3	3.7	
掛数	2	2	2	2	2
危険角度 (°)	40	41	41	45	60
フック種類	24t	24t	24t	24t	24t
フック質量 (t)	0.88	0.88	0.88	0.88	0.88

HC性能

50.0mブーム+4.4m+22mヘビーリフトジブ

オフセット	10°	20°	30°	45°	60°
作業半径 (m)	荷重 (ton)	荷重 (ton)	荷重 (ton)	荷重 (ton)	荷重 (ton)
18.0	11.0				
20.0	11.0				
22.0	11.0	11.0			
24.0	11.0	11.0	11.0		
26.0	11.0	11.0	11.0		
28.0	11.0	11.0	10.9	9.1	
30.0	11.0	11.0	10.8	9.1	7.5
32.0	11.0	11.0	10.6	9.0	7.5
34.0	10.0	10.9	10.5	9.0	7.5
36.0	8.7	9.6	10.3	8.9	7.5
38.0	7.6	8.4	9.1	8.9	7.5
40.0	6.6	7.3	7.9	8.7	7.5
42.0	5.6	6.3	6.9	7.6	7.5
44.0	4.5	5.4	6.0	6.6	6.9
46.0	3.6	4.4	5.1	5.7	
48.0	2.7	3.4	4.1	4.7	
50.0			3.1	3.7	
掛数	2	2	2	2	2
危険角度 (°)	50	50	51	51	60
フック種類	24t	24t	24t	24t	24t
フック質量 (t)	0.88	0.88	0.88	0.88	0.88

HC性能

45.5mブーム+4.4m+22mヘビーリフトジブ

オフセット	10°	20°	30°	45°	60°
作業半径 (m)	荷重 (ton)	荷重 (ton)	荷重 (ton)	荷重 (ton)	荷重 (ton)
16.0	16.0				
18.0	16.0				
20.0	16.0	16.0			
22.0	16.0	16.0			
24.0	16.0	16.0	16.0		
26.0	16.0	16.0	16.0		
28.0	15.4	16.0	16.0	15.6	
30.0	13.4	14.4	15.4	15.4	13.0
32.0	11.7	12.6	13.5	14.6	13.0
34.0	10.2	11.1	11.9	12.9	12.9
36.0	8.9	9.7	10.4	11.3	11.9
38.0	7.8	8.5	9.2	9.9	10.4
40.0	6.8	7.4	8.0	8.7	9.1
42.0	5.9	6.5	7.0	7.6	7.9
44.0	4.8	5.6	6.1	6.6	
46.0	3.8	4.6	5.2	5.7	
48.0	2.9	3.6	4.2	4.8	
50.0		2.7	3.2	3.7	
掛数	2	2	2	2	2
危険角度 (°)	46	46	47	47	60
フック種類	24t	24t	24t	24t	24t
フック質量 (t)	0.88	0.88	0.88	0.88	0.88

HC性能

13.6mブーム+4.4m+31mヘビーリフトジブ

オフセット	10°	20°	30°	45°	60°
作業半径 (m)	荷重 (ton)	荷重 (ton)	荷重 (ton)	荷重 (ton)	荷重 (ton)
14.0	35.0				
16.0	34.4				
18.0	34.4	33.8			
20.0	33.2	31.5			
22.0	28.7	29.1	26.1		
24.0	25.2	26.2	24.5		
26.0	22.3	23.2	23.1		
28.0	19.9	20.7	21.5	18.8	
30.0	17.9	18.6	19.3	18.0	
32.0	16.2	16.8	17.4	17.3	12.7
34.0	14.7	15.2	15.7	16.5	12.4
36.0	13.3	13.8	14.3	14.9	12.2
38.0	12.2	12.6	13.0	13.5	
40.0	11.2	11.5	11.8	12.2	
42.0	10.2	10.5	10.7		
44.0	9.4	9.6	9.7		
46.0	8.7				
掛数	4	4	4	4	4
危険角度 (°)	10	20	30	45	60
フック種類	83t	83t	83t	83t	83t
フック質量 (t)	1.00	1.00	1.00	1.00	1.00

HC性能

22.7mブーム+4.4m+31mヘビーリフトジブ

オフセット	10°	20°	30°	45°	60°
作業半径 (m)	荷重 (ton)	荷重 (ton)	荷重 (ton)	荷重 (ton)	荷重 (ton)
16.0	30.0				
18.0	30.0				
20.0	30.0	30.0			
22.0	26.4	28.2			
24.0	22.8	24.4	25.8		
26.0	20.0	21.4	22.8		
28.0	17.6	18.8	20.1		
30.0	15.5	16.7	17.8	19.3	
32.0	13.8	14.8	15.8	17.2	
34.0	12.3	13.2	14.1	15.3	14.5
36.0	11.0	11.8	12.6	13.7	14.2
38.0	9.8	10.5	11.3	12.2	12.9
40.0	8.8	9.4	10.1	10.9	11.4
42.0	7.8	8.4	9.0	9.7	
44.0	7.0	7.5	8.0	8.6	
46.0	6.3	6.7	7.1	7.6	
48.0	5.6	6.0	6.3		
50.0	5.0	5.3	5.5		
55.0	3.2				
掛数	4	4	4	4	4
危険角度 (°)	10	20	30	45	60
フック種類	83t	83t	83t	83t	83t
フック質量 (t)	1.00	1.00	1.00	1.00	1.00

HC性能

18.15mブーム+4.4m+31mヘビーリフトジブ

オフセット	10°	20°	30°	45°	60°
作業半径 (m)	荷重 (ton)	荷重 (ton)	荷重 (ton)	荷重 (ton)	荷重 (ton)
14.0	34.0				
16.0	34.0				
18.0	34.0	34.0			
20.0	31.9	32.8			
22.0	27.5	29.0	26.8		
24.0	23.9	25.3	25.2		
26.0	21.1	22.2	23.4		
28.0	18.7	19.7	20.7	19.8	
30.0	16.6	17.6	18.5	19.1	
32.0	14.9	15.7	16.5	17.7	13.9
34.0	13.4	14.1	14.8	15.9	13.6
36.0	12.1	12.7	13.4	14.2	13.4
38.0	10.9	11.5	12.0	12.8	13.2
40.0	9.9	10.4	10.9	11.5	
42.0	8.9	9.4	9.8	10.3	
44.0	8.1	8.5	8.8	9.2	
46.0	7.4	7.7	7.9		
48.0	6.7	6.9	7.0		
50.0	6.1				
掛数	4	4	4	4	4
危険角度 (°)	10	20	30	45	60
フック種類	83t	83t	83t	83t	83t
フック質量 (t)	1.00	1.00	1.00	1.00	1.00

HC性能

31.8mブーム+4.4m+31mヘビーリフトジブ

オフセット	10°	20°	30°	45°	60°
作業半径 (m)	荷重 (ton)	荷重 (ton)	荷重 (ton)	荷重 (ton)	荷重 (ton)
16.0	20.0				
18.0	20.0				
20.0	20.0				
22.0	20.0	20.0			
24.0	20.0	20.0			
26.0	19.6	20.0	19.4		
28.0	17.2	18.6	18.9		
30.0	15.1	16.4	17.7	15.6	
32.0	13.4	14.6	15.7	15.3	
34.0	11.9	12.9	13.9	15.1	12.4
36.0	10.5	11.5	12.4	13.7	12.3
38.0	9.4	10.3	11.1	12.2	12.3
40.0	8.3	9.1	9.9	10.9	11.6
42.0	7.4	8.1	8.8	9.7	10.3
44.0	6.6	7.2	7.9	8.6	9.1
46.0	5.8	6.4	7.0	7.6	8.0
48.0	5.1	5.7	6.2	6.7	
50.0	4.3	5.0	5.4	5.9	
55.0		3.0	3.4		
掛数	2	2	2	2	2
危険角度 (°)	33	33	34	45	60
フック種類	24t	24t	24t	24t	24t
フック質量 (t)	0.88	0.88	0.88	0.88	0.88

HC性能

40.9mブーム+4.4m+31mヘビーリフトジブ

オフセット	10°	20°	30°	45°	60°
作業半径 (m)	荷重 (ton)	荷重 (ton)	荷重 (ton)	荷重 (ton)	荷重 (ton)
18.0	14.0				
20.0	14.0				
22.0	14.0				
24.0	14.0	14.0			
26.0	14.0	14.0			
28.0	14.0	14.0	14.0		
30.0	14.0	14.0	14.0		
32.0	12.9	14.0	14.0		
34.0	11.4	12.5	13.6	14.0	
36.0	10.0	11.1	12.1	13.5	
38.0	8.9	9.9	10.8	12.0	13.0
40.0	7.8	8.7	9.6	10.7	11.5
42.0	6.9	7.7	8.5	9.5	10.2
44.0	6.1	6.8	7.6	8.5	9.1
46.0	5.3	6.0	6.7	7.5	8.0
48.0	4.4	5.3	5.9	6.6	7.0
50.0	3.5	4.4	5.1	5.8	6.1
55.0				3.7	
掛数	2	2	2	2	2
危険角度 (°)	46	47	47	48	60
フック種類	24t	24t	24t	24t	24t
フック質量 (t)	0.88	0.88	0.88	0.88	0.88

HC性能

50.0mブーム+4.4m+31mヘビーリフトジブ

オフセット	10°	20°	30°	45°	60°
作業半径 (m)	荷重 (ton)	荷重 (ton)	荷重 (ton)	荷重 (ton)	荷重 (ton)
20.0	9.0				
22.0	9.0				
24.0	9.0				
26.0	9.0	9.0			
28.0	9.0	9.0			
30.0	9.0	9.0	7.8		
32.0	9.0	8.8	7.7		
34.0	9.0	8.6	7.5		
36.0	9.0	8.4	7.4	6.0	
38.0	8.4	8.2	7.3	5.9	4.7
40.0	7.4	8.1	7.2	5.9	4.6
42.0	6.5	7.4	7.1	5.8	4.6
44.0	5.6	6.5	7.0	5.8	4.6
46.0	4.7	5.7	6.4	5.8	4.6
48.0	3.7	4.8	5.6	5.8	4.6
50.0		3.9	4.9	5.7	4.6
55.0				3.6	
掛数	2	2	2	2	2
危険角度 (°)	55	56	56	56	60
フック種類	24t	24t	24t	24t	24t
フック質量 (t)	0.88	0.88	0.88	0.88	0.88

HC性能

45.5mブーム+4.4m+31mヘビーリフトジブ

オフセット	10°	20°	30°	45°	60°
作業半径 (m)	荷重 (ton)	荷重 (ton)	荷重 (ton)	荷重 (ton)	荷重 (ton)
20.0	12.0				
22.0	12.0				
24.0	12.0	12.0			
26.0	12.0	12.0			
28.0	12.0	12.0			
30.0	12.0	12.0	12.0		
32.0	12.0	12.0	12.0		
34.0	11.1	12.0	12.0	11.1	
36.0	9.8	10.9	12.0	11.0	
38.0	8.6	9.7	10.6	10.9	8.9
40.0	7.6	8.6	9.5	10.6	8.9
42.0	6.7	7.6	8.4	9.5	8.8
44.0	5.8	6.7	7.4	8.4	8.8
46.0	4.9	5.8	6.5	7.4	8.0
48.0	4.0	5.1	5.7	6.5	7.0
50.0	3.2	4.2	5.0	5.7	6.1
55.0			2.9	3.7	
掛数	2	2	2	2	2
危険角度 (°)	50	51	51	52	60
フック種類	24t	24t	24t	24t	24t
フック質量 (t)	0.88	0.88	0.88	0.88	0.88

HC性能

13.6mブーム+4.4m+40mヘビーリフトジブ

オフセット	10°	20°	30°	45°	60°
作業半径 (m)	荷重 (ton)	荷重 (ton)	荷重 (ton)	荷重 (ton)	荷重 (ton)
16.0	12.0				
18.0	12.0				
20.0	12.0				
22.0	12.0	12.0			
24.0	12.0	12.0			
26.0	12.0	12.0			
28.0	12.0	12.0	12.0		
30.0	12.0	12.0	12.0		
32.0	12.0	12.0	12.0		
34.0	12.0	12.0	12.0		
36.0	12.0	12.0	12.0	11.8	
38.0	12.0	12.0	12.0	11.2	
40.0	12.0	12.0	11.9	10.7	9.4
42.0	11.2	11.7	11.3	10.2	9.2
44.0	10.3	10.7	10.7	9.8	9.0
46.0	9.6	9.9	10.3	9.5	8.9
48.0	8.8	9.2	9.5	9.2	
50.0	8.2	8.5	8.7	9.0	
55.0	6.8				
掛数	1	1	1	1	1
危険角度 (°)	10	20	30	45	60
フック種類	12t	12t	12t	12t	12t
フック質量 (t)	0.53	0.53	0.53	0.53	0.53

HC性能

22.7mブーム+4.4m+40mヘビーリフトジブ

オフセット	10°	20°	30°	45°	60°
作業半径 (m)	荷重 (ton)	荷重 (ton)	荷重 (ton)	荷重 (ton)	荷重 (ton)
18.0	12.0				
20.0	12.0				
22.0	12.0				
24.0	12.0	12.0			
26.0	12.0	12.0			
28.0	12.0	12.0			
30.0	12.0	12.0	12.0		
32.0	12.0	12.0	12.0		
34.0	12.0	12.0	12.0		
36.0	12.0	12.0	12.0	12.0	
38.0	11.2	12.0	12.0	11.7	
40.0	10.1	11.0	11.9	11.3	
42.0	9.1	10.0	10.8	10.8	9.7
44.0	8.3	9.0	9.8	10.5	9.5
46.0	7.5	8.2	8.9	9.8	9.3
48.0	6.8	7.4	8.0	8.8	9.1
50.0	6.1	6.7	7.3	8.0	8.4
55.0	4.7	5.2	5.5	6.0	
60.0	3.3	3.7	3.9		
掛数	1	1	1	1	1
危険角度 (°)	10	20	30	45	60
フック種類	12t	12t	12t	12t	12t
フック質量 (t)	0.53	0.53	0.53	0.53	0.53

HC性能

18.15mブーム+4.4m+40mヘビーリフトジブ

オフセット	10°	20°	30°	45°	60°
作業半径 (m)	荷重 (ton)	荷重 (ton)	荷重 (ton)	荷重 (ton)	荷重 (ton)
18.0	12.0				
20.0	12.0				
22.0	12.0				
24.0	12.0	12.0			
26.0	12.0	12.0			
28.0	12.0	12.0			
30.0	12.0	12.0	12.0		
32.0	12.0	12.0	12.0		
34.0	12.0	12.0	12.0		
36.0	12.0	12.0	12.0	12.0	
38.0	12.0	12.0	12.0	11.5	
40.0	11.0	11.8	12.0	11.0	9.9
42.0	10.1	10.8	11.4	10.6	9.6
44.0	9.2	9.8	10.4	10.2	9.3
46.0	8.5	9.0	9.5	9.8	9.2
48.0	7.8	8.2	8.7	9.3	9.0
50.0	7.1	7.5	7.9	8.5	
55.0	5.7	6.0	6.2		
60.0	4.5				
掛数	1	1	1	1	1
危険角度 (°)	10	20	30	45	60
フック種類	12t	12t	12t	12t	12t
フック質量 (t)	0.53	0.53	0.53	0.53	0.53

HC性能

31.8mブーム+4.4m+40mヘビーリフトジブ

オフセット	10°	20°	30°	45°	60°
作業半径 (m)	荷重 (ton)	荷重 (ton)	荷重 (ton)	荷重 (ton)	荷重 (ton)
20.0	12.0				
22.0	12.0				
24.0	12.0				
26.0	12.0	12.0			
28.0	12.0	12.0			
30.0	12.0	12.0			
32.0	12.0	12.0	12.0		
34.0	12.0	12.0	12.0		
36.0	11.7	12.0	12.0		
38.0	10.5	11.6	12.0	12.0	
40.0	9.5	10.5	11.5	11.7	
42.0	8.5	9.5	10.4	11.3	
44.0	7.6	8.5	9.4	10.6	9.5
46.0	6.9	7.7	8.5	9.6	9.4
48.0	6.2	6.9	7.7	8.6	9.3
50.0	5.5	6.2	6.9	7.8	8.4
55.0	3.9	4.7	5.2	5.9	6.2
60.0	2.4	3.0	3.6	4.2	
65.0		1.5	1.9		
掛数	1	1	1	1	1
危険角度 (°)	32	33	33	45	60
フック種類	12t	12t	12t	12t	12t
フック質量 (t)	0.53	0.53	0.53	0.53	0.53

HC性能

40.9mブーム+4.4m+40mヘビーリフトジブ

オフセット	10°	20°	30°	45°	60°
作業半径 (m)	荷重 (ton)	荷重 (ton)	荷重 (ton)	荷重 (ton)	荷重 (ton)
22.0	11.0				
24.0	11.0				
26.0	11.0				
28.0	11.0	11.0			
30.0	11.0	11.0			
32.0	11.0	11.0			
34.0	11.0	11.0	11.0		
36.0	11.0	11.0	11.0		
38.0	10.0	11.0	11.0		
40.0	8.9	10.1	11.0		
42.0	8.0	9.1	10.1	11.0	
44.0	7.1	8.1	9.1	10.4	
46.0	6.3	7.3	8.2	9.4	9.6
48.0	5.6	6.5	7.3	8.5	9.3
50.0	5.0	5.8	6.6	7.6	8.4
55.0	3.1	4.1	4.9	5.7	6.3
60.0	1.6	2.4	3.2	4.1	
65.0			1.6	2.2	
掛数	1	1	1	1	1
危険角度 (°)	45	46	47	47	60
フック種類	12t	12t	12t	12t	12t
フック質量 (t)	0.53	0.53	0.53	0.53	0.53

HC性能

50.0mブーム+4.4m+40mヘビーリフトジブ

オフセット	10°	20°	30°	45°	60°
作業半径 (m)	荷重 (ton)	荷重 (ton)	荷重 (ton)	荷重 (ton)	荷重 (ton)
24.0	7.0				
26.0	7.0				
28.0	7.0				
30.0	7.0	7.0			
32.0	7.0	7.0			
34.0	7.0	7.0			
36.0	7.0	6.8	5.9		
38.0	7.0	6.7	5.8		
40.0	7.0	6.5	5.6		
42.0	7.0	6.4	5.5		
44.0	6.7	6.2	5.4	4.3	
46.0	5.9	6.1	5.3	4.2	
48.0	5.2	6.0	5.2	4.2	3.1
50.0	4.3	5.4	5.2	4.1	3.1
55.0		3.6	4.6	4.1	3.1
60.0			2.8	3.9	3.1
65.0				2.1	
掛数	1	1	1	1	1
危険角度 (°)	56	57	57	57	60
フック種類	12t	12t	12t	12t	12t
フック質量 (t)	0.53	0.53	0.53	0.53	0.53

HC性能

45.5mブーム+4.4m+40mヘビーリフトジブ

オフセット	10°	20°	30°	45°	60°
作業半径 (m)	荷重 (ton)	荷重 (ton)	荷重 (ton)	荷重 (ton)	荷重 (ton)
24.0	10.0				
26.0	10.0				
28.0	10.0				
30.0	10.0	10.0			
32.0	10.0	10.0			
34.0	10.0	10.0			
36.0	10.0	10.0	10.0		
38.0	9.8	10.0	10.0		
40.0	8.7	9.9	10.0		
42.0	7.7	8.9	10.0	8.5	
44.0	6.9	7.9	8.9	8.3	
46.0	6.1	7.1	8.0	8.2	6.6
48.0	5.4	6.3	7.2	8.1	6.5
50.0	4.6	5.6	6.4	7.5	6.5
55.0	2.8	3.9	4.8	5.7	6.2
60.0		2.2	3.0	4.0	4.5
65.0				2.2	
掛数	1	1	1	1	1
危険角度 (°)	51	52	52	53	60
フック種類	12t	12t	12t	12t	12t
フック質量 (t)	0.53	0.53	0.53	0.53	0.53

HC性能

13.6mブーム+4.4m+47mヘビーリフトジブ

オフセット	10°	20°	30°	45°	60°
作業半径 (m)	荷重 (ton)	荷重 (ton)	荷重 (ton)	荷重 (ton)	荷重 (ton)
18.0	12.0				
20.0	12.0				
22.0	12.0				
24.0	12.0				
26.0	12.0	12.0			
28.0	12.0	12.0			
30.0	12.0	12.0			
32.0	12.0	12.0	12.0		
34.0	12.0	12.0	12.0		
36.0	12.0	12.0	11.7		
38.0	12.0	12.0	10.9		
40.0	12.0	11.2	10.3		
42.0	11.5	10.5	9.7	8.6	
44.0	10.6	9.9	9.2	8.2	
46.0	9.8	9.4	8.7	7.8	7.1
48.0	9.1	8.8	8.2	7.5	6.9
50.0	8.5	8.4	7.9	7.2	6.7
55.0	7.1	7.4	7.1	6.6	
60.0	5.9	6.1	6.2		
掛数	1	1	1	1	1
危険角度 (°)	10	20	30	45	60
フック種類	12t	12t	12t	12t	12t
フック質量 (t)	0.53	0.53	0.53	0.53	0.53

HC性能

22.7mブーム+4.4m+47mヘビーリフトジブ

オフセット	10°	20°	30°	45°	60°
作業半径 (m)	荷重 (ton)	荷重 (ton)	荷重 (ton)	荷重 (ton)	荷重 (ton)
20.0	12.0				
22.0	12.0				
24.0	12.0				
26.0	12.0				
28.0	12.0	12.0			
30.0	12.0	12.0			
32.0	12.0	12.0			
34.0	12.0	12.0	12.0		
36.0	12.0	12.0	12.0		
38.0	11.7	12.0	11.7		
40.0	10.6	11.6	11.1		
42.0	9.6	10.6	10.5	8.9	
44.0	8.8	9.6	10.0	8.6	
46.0	8.0	8.8	9.5	8.2	
48.0	7.2	8.0	8.8	7.9	7.1
50.0	6.6	7.3	8.0	7.6	6.9
55.0	5.2	5.8	6.3	7.0	6.5
60.0	3.9	4.5	4.9	5.4	
65.0	2.6	3.1	3.5		
70.0	1.4	1.6			
掛数	1	1	1	1	1
危険角度 (°)	14	20	30	45	60
フック種類	12t	12t	12t	12t	12t
フック質量 (t)	0.53	0.53	0.53	0.53	0.53

HC性能

18.15mブーム+4.4m+47mヘビーリフトジブ

オフセット	10°	20°	30°	45°	60°
作業半径 (m)	荷重 (ton)	荷重 (ton)	荷重 (ton)	荷重 (ton)	荷重 (ton)
20.0	12.0				
22.0	12.0				
24.0	12.0				
26.0	12.0	12.0			
28.0	12.0	12.0			
30.0	12.0	12.0			
32.0	12.0	12.0			
34.0	12.0	12.0	12.0		
36.0	12.0	12.0	12.0		
38.0	12.0	12.0	11.3		
40.0	11.5	12.0	10.7		
42.0	10.5	11.2	10.1	8.8	
44.0	9.6	10.3	9.6	8.4	
46.0	8.8	9.5	9.1	8.0	
48.0	8.1	8.7	8.7	7.7	7.0
50.0	7.5	8.0	8.3	7.4	6.8
55.0	6.1	6.5	6.9	6.8	6.5
60.0	4.9	5.2	5.5	5.8	
65.0	3.9	4.1			
掛数	1	1	1	1	1
危険角度 (°)	10	20	30	45	60
フック種類	12t	12t	12t	12t	12t
フック質量 (t)	0.53	0.53	0.53	0.53	0.53

HC性能

31.8mブーム+4.4m+47mヘビーリフトジブ

オフセット	10°	20°	30°	45°	60°
作業半径 (m)	荷重 (ton)	荷重 (ton)	荷重 (ton)	荷重 (ton)	荷重 (ton)
22.0	12.0				
24.0	12.0				
26.0	12.0				
28.0	12.0				
30.0	12.0	12.0			
32.0	12.0	12.0			
34.0	12.0	12.0			
36.0	12.0	12.0	12.0		
38.0	11.0	12.0	12.0		
40.0	9.9	11.1	11.8		
42.0	9.0	10.1	11.2		
44.0	8.1	9.1	10.2	8.8	
46.0	7.3	8.3	9.2	8.5	
48.0	6.6	7.5	8.4	8.2	
50.0	5.9	6.8	7.6	8.0	7.0
55.0	4.5	5.2	5.9	6.9	6.7
60.0	3.0	3.8	4.5	5.2	5.7
65.0	1.7	2.4	3.0	3.8	
70.0			1.6	2.0	
掛数	1	1	1	1	1
危険角度 (°)	38	39	40	45	60
フック種類	12t	12t	12t	12t	12t
フック質量 (t)	0.53	0.53	0.53	0.53	0.53

HC性能

40.9mブーム+4.4m+47mヘビーリフトジブ

オフセット	10°	20°	30°	45°	60°
作業半径 (m)	荷重 (ton)	荷重 (ton)	荷重 (ton)	荷重 (ton)	荷重 (ton)
26.0	8.0				
28.0	8.0				
30.0	8.0				
32.0	8.0	8.0			
34.0	8.0	8.0			
36.0	8.0	8.0			
38.0	8.0	8.0			
40.0	8.0	8.0	8.0		
42.0	8.0	8.0	8.0		
44.0	7.5	8.0	8.0		
46.0	6.8	7.9	8.0		
48.0	6.0	7.1	8.0	8.0	
50.0	5.4	6.4	7.3	8.0	
55.0	3.7	4.8	5.6	6.7	6.8
60.0	2.2	3.2	4.2	5.1	5.7
65.0		1.7	2.6	3.6	4.1
70.0				1.9	
掛数	1	1	1	1	1
危険角度 (°)	49	50	51	51	60
フック種類	12t	12t	12t	12t	12t
フック質量 (t)	0.53	0.53	0.53	0.53	0.53

HC性能

50.0mブーム+4.4m+47mヘビーリフトジブ

オフセット	10°	20°	30°	45°	60°
作業半径 (m)	荷重 (ton)	荷重 (ton)	荷重 (ton)	荷重 (ton)	荷重 (ton)
26.0	5.0				
28.0	5.0				
30.0	5.0				
32.0	5.0				
34.0	5.0	5.0			
36.0	5.0	5.0			
38.0	5.0	5.0			
40.0	5.0	5.0	4.5		
42.0	5.0	5.0	4.4		
44.0	5.0	5.0	4.3		
46.0	5.0	4.9	4.2		
48.0	5.0	4.8	4.1	3.1	
50.0	4.9	4.7	4.0	3.0	
55.0		4.4	3.8	2.9	2.0
60.0		2.7	3.7	2.8	2.0
65.0				2.8	2.0
70.0					2.0
掛数	1	1	1	1	1
危険角度 (°)	59	59	60	60	60
フック種類	12t	12t	12t	12t	12t
フック質量 (t)	0.53	0.53	0.53	0.53	0.53

HC性能

45.5mブーム+4.4m+47mヘビーリフトジブ

オフセット	10°	20°	30°	45°	60°
作業半径 (m)	荷重 (ton)	荷重 (ton)	荷重 (ton)	荷重 (ton)	荷重 (ton)
26.0	7.5				
28.0	7.5				
30.0	7.5				
32.0	7.5				
34.0	7.5	7.5			
36.0	7.5	7.5			
38.0	7.5	7.5			
40.0	7.5	7.5	7.5		
42.0	7.5	7.5	7.5		
44.0	7.3	7.5	7.5		
46.0	6.5	7.5	7.5		
48.0	5.8	6.9	7.5	6.7	
50.0	5.1	6.2	7.1	6.6	
55.0	3.3	4.6	5.4	6.4	4.9
60.0		2.9	4.0	5.0	4.9
65.0			2.4	3.5	4.1
70.0				1.8	
掛数	1	1	1	1	1
危険角度 (°)	54	55	56	56	60
フック種類	12t	12t	12t	12t	12t
フック質量 (t)	0.53	0.53	0.53	0.53	0.53

HC性能

13.6mブーム+4.4m+54mヘビーリフトジブ

オフセット	10°	20°	30°	45°	60°
作業半径 (m)	荷重 (ton)	荷重 (ton)	荷重 (ton)	荷重 (ton)	荷重 (ton)
22.0	9.3				
24.0	9.3				
26.0	9.3				
28.0	9.3				
30.0	9.1	8.9			
32.0	9.1	8.8			
34.0	9.0	8.8			
36.0	8.9	8.6			
38.0	8.7	8.2	7.7		
40.0	8.4	7.9	7.4		
42.0	8.0	7.6	7.2		
44.0	7.7	7.3	6.9		
46.0	7.4	7.0	6.7	6.2	
48.0	7.1	6.8	6.5	6.1	
50.0	6.9	6.6	6.3	5.9	
55.0	6.3	6.1	5.9	5.4	4.9
60.0	5.8	5.6	5.3	4.9	4.6
65.0	5.1	5.0	4.8		
掛数	1	1	1	1	1
危険角度 (°)	10	20	30	45	60
フック種類	12t	12t	12t	12t	12t
フック質量 (t)	0.53	0.53	0.53	0.53	0.53

HC性能

22.7mブーム+4.4m+54mヘビーリフトジブ

オフセット	10°	20°	30°	45°	60°
作業半径 (m)	荷重 (ton)	荷重 (ton)	荷重 (ton)	荷重 (ton)	荷重 (ton)
24.0	9.3				
26.0	9.3				
28.0	9.3				
30.0	9.1				
32.0	9.1	8.9			
34.0	9.1	8.8			
36.0	9.0	8.7			
38.0	8.9	8.6	7.9		
40.0	8.8	8.3	7.7		
42.0	8.7	8.0	7.4		
44.0	8.4	7.7	7.2		
46.0	8.1	7.5	7.0		
48.0	7.6	7.2	6.8	6.2	
50.0	6.9	7.0	6.6	6.0	
55.0	5.5	6.2	6.2	5.7	5.1
60.0	4.3	4.9	5.5	5.2	4.8
65.0	3.1	3.8	4.3	4.8	4.6
70.0	2.0	2.5	3.0	3.5	
75.0		1.3	1.5		
掛数	1	1	1	1	1
危険角度 (°)	24	24	30	45	60
フック種類	12t	12t	12t	12t	12t
フック質量 (t)	0.53	0.53	0.53	0.53	0.53

HC性能

18.15mブーム+4.4m+54mヘビーリフトジブ

オフセット	10°	20°	30°	45°	60°
作業半径 (m)	荷重 (ton)	荷重 (ton)	荷重 (ton)	荷重 (ton)	荷重 (ton)
22.0	9.3				
24.0	9.3				
26.0	9.3				
28.0	9.3				
30.0	9.1	9.0			
32.0	9.1	9.0			
34.0	9.1	8.9			
36.0	8.9	8.8			
38.0	8.8	8.4	7.8		
40.0	8.7	8.1	7.6		
42.0	8.4	7.8	7.3		
44.0	8.0	7.5	7.1		
46.0	7.7	7.3	6.8		
48.0	7.5	7.0	6.6	6.1	
50.0	7.2	6.8	6.4	6.0	
55.0	6.3	6.3	6.0	5.5	5.0
60.0	5.2	5.6	5.6	5.0	4.7
65.0	4.2	4.5	4.9	4.7	
70.0	3.2	3.5	3.8		
掛数	1	1	1	1	1
危険角度 (°)	10	20	30	45	60
フック種類	12t	12t	12t	12t	12t
フック質量 (t)	0.53	0.53	0.53	0.53	0.53

HC性能

31.8mブーム+4.4m+54mヘビーリフトジブ

オフセット	10°	20°	30°	45°	60°
作業半径 (m)	荷重 (ton)	荷重 (ton)	荷重 (ton)	荷重 (ton)	荷重 (ton)
26.0	9.0				
28.0	9.0				
30.0	9.0				
32.0	9.0	8.9			
34.0	9.0	8.8			
36.0	9.0	8.7			
38.0	8.9	8.7			
40.0	8.8	8.7	7.9		
42.0	8.7	8.4	7.6		
44.0	8.5	8.1	7.4		
46.0	7.7	7.9	7.2		
48.0	6.9	7.6	7.0		
50.0	6.3	7.2	6.8	6.1	
55.0	4.8	5.7	6.4	5.8	
60.0	3.4	4.4	5.1	5.5	4.9
65.0	2.1	3.0	3.9	4.7	4.7
70.0		1.7	2.4	3.3	
75.0				1.7	
掛数	1	1	1	1	1
危険角度 (°)	45	45	45	45	60
フック種類	12t	12t	12t	12t	12t
フック質量 (t)	0.53	0.53	0.53	0.53	0.53

HC性能

40.9mブーム+4.4m+54mヘビーリフトジブ

オフセット	10°	20°	30°	45°	60°
作業半径 (m)	荷重 (ton)	荷重 (ton)	荷重 (ton)	荷重 (ton)	荷重 (ton)
28.0	6.0				
30.0	6.0				
32.0	6.0				
34.0	6.0				
36.0	6.0	6.0			
38.0	6.0	6.0			
40.0	6.0	6.0			
42.0	6.0	6.0			
44.0	6.0	6.0	6.0		
46.0	6.0	6.0	6.0		
48.0	6.0	6.0	6.0		
50.0	5.7	6.0	6.0		
55.0	4.2	5.2	6.0	5.9	
60.0	2.6	3.8	4.7	5.7	4.9
65.0		2.4	3.4	4.5	4.7
70.0			1.9	3.1	3.7
75.0				1.6	
掛数	1	1	1	1	1
危険角度 (°)	53	54	55	55	60
フック種類	12t	12t	12t	12t	12t
フック質量 (t)	0.53	0.53	0.53	0.53	0.53

HC性能

50.0mブーム+4.4m+54mヘビーリフトジブ

オフセット	10°	20°	30°	45°	60°
作業半径 (m)	荷重 (ton)	荷重 (ton)	荷重 (ton)	荷重 (ton)	荷重 (ton)
30.0	4.1				
32.0	4.1				
34.0	4.1				
36.0	4.1				
38.0	4.1	4.1			
40.0	4.1	4.1			
42.0	4.1	4.1			
44.0	4.1	4.0			
46.0	4.1	3.9	3.2		
48.0	4.1	3.8	3.1		
50.0	4.1	3.7	3.0		
55.0	3.5	3.4	2.8	2.0	
60.0		3.2	2.7	1.9	
65.0			2.6	1.8	
70.0				1.8	
掛数	1	1	1	1	1
危険角度 (°)	61	62	63	64	64
フック種類	12t	12t	12t	12t	12t
フック質量 (t)	0.53	0.53	0.53	0.53	0.53

HC性能

45.5mブーム+4.4m+54mヘビーリフトジブ

オフセット	10°	20°	30°	45°	60°
作業半径 (m)	荷重 (ton)	荷重 (ton)	荷重 (ton)	荷重 (ton)	荷重 (ton)
28.0	5.5				
30.0	5.5				
32.0	5.5				
34.0	5.5				
36.0	5.5	5.5			
38.0	5.5	5.5			
40.0	5.5	5.5			
42.0	5.5	5.5			
44.0	5.5	5.5	5.5		
46.0	5.5	5.5	5.5		
48.0	5.5	5.5	5.5		
50.0	5.5	5.5	5.5		
55.0	3.8	5.0	5.5	5.2	
60.0		3.5	4.6	5.0	3.7
65.0			3.1	4.4	3.6
70.0				2.9	3.6
75.0					2.0
掛数	1	1	1	1	1
危険角度 (°)	58	59	59	60	60
フック種類	12t	12t	12t	12t	12t
フック質量 (t)	0.53	0.53	0.53	0.53	0.53

KA-2200



▲ 右側面

▲ フロント



▲ 左側面

▲ リヤ

※構内走行姿勢

<http://www.kato-works.co.jp>

- 本機は公道を走行する場合には、旋回体を別送し台車のみで走行しなければなりません。
- 本機は道路法による基本通行条件のC条件相当車です。

●本カタログの写真ならびに装備は、改良などによりお届けいたします製品と異なる場合があります。また、仕様は予告なく変更することがありますのであらかじめご了承ください。●ボディカラーおよび内装色は撮影や印刷インクの関係で実際の色と異なって見えることがあります。●本機の使用にあたっての注意事項は、取扱説明書の内容をよく読んで正しくお使いください。

●お問合せは…

KATO 株式会社 加藤製作所

本 社 / ☎140-0011 東京都品川区東大井1丁目9番37号
☎03(3458)1111番(大代表)



品質保証の国際規格「ISO 9001」の認証を取得しています。

C02431
8.2008-2000(AT)1

ALLTERR.[®] KA-2200



KATO

All Terrain Crane

220t

- 最先端のスーパーブームを搭載
- 3段式SLジブとヘビーリフトジブ、双方を標準装備
- 静かな新型エンジン搭載（クレーン用）
- クリーンな新型エンジン搭載（キャリア用）
- サイドサポートの装備で、さらに強力な作業性能を発揮
- 超大型にもかかわらず、群を抜く小回り性能
- 機体3分割方式でスピーディな着脱
- ウエイト装着のフル装備でも現場内移動が可能

KA-2200



※重荷重装置使用時の作業姿勢

●荷重試験姿勢
(実際のクレーン作業姿勢とは異なります)

接近、高揚程、遠隔作業。
自在なコーディネートでさらに広がる作業性。

ヘビーリフトジブ & スーパーラフティングジブ

2種類のジブが標準装備。



スーパーブーム SUPERBOOM

強靭さを生み出す独特な丸型断面構造。
[タテ・ヨコ] 両方向のたわみが少ない
高剛性スーパーブーム。

■ブーム吊り上げ能力

- 最大吊り上げ能力……………220t×3.0m*
- ブーム長さ……………13.6m~50.0m
- 最大地上揚程……………51.0m
- ブーム最大起伏角度……………83°
- フルブーム時最大定格総荷重……………35.0t

*重荷重装置付、後方性能のみ

軽量にしてスピーディ。
5段油圧式を採用。

- 伸縮スピードが速く、ストロークも長い。
ピンロック方式よりも多様な作業条件に対応し、
高い剛性・信頼性を有します。

短時間で簡単着脱。
3段式スーパーラフティングジブ。



- SLジブ長さ……………1.5mベースブラケット+
10.5m~27.3m
- SLジブオフセット角度……………5°~60°

■スーパーラフティングジブ 吊り上げ能力

- 最大地上揚程……………79.0m
- 50.0m+1.5m+27.3mSL (5°)
ブーム最起立~作業半径30.0mまで……………7.0t
- 45.5m+1.5m+10.5mSL (5°)
ブーム最起立~作業半径16mまで……………24.0t
- 50.0m+1.5m+27.3mSL (30°)
最大作業半径62.0m時……………2.0t

- 橋梁工事、プラント建設、高層ビル工事等の重量物荷役に。
また、ビル越し、工場越し、屋上作業等の高揚程接近作業・遠隔作業にも、一段と広い用途に、強力な作業性能を発揮します。
- 取付、取外しはリモコンスイッチ操作で容易に行えます。

さらに高く、遠くまで!
ふところの深いヘビーリフトジブ。

- 6種の長さ、自在にセットアップ可能。
4.4mベースブラケット+
13m・22m・31m・40m・47m・54m
- 無段階起伏……………10°~60°
- KATO独自の機構により、立組・解体もスピーディ。
ヘビーリフトジブの立組・解体は、スペースをとらず、狭い現場内でも効率よく行えます。

■ヘビーリフトジブ 吊り上げ能力

- 最大地上揚程……………106.9m
- 13.6m+4.4m+13.0mHL (10°)
最大吊り上げ能力……………84.0t×9.0m
- 50.0m+4.4m+54.0mHL (10°)
ブーム最起立~作業半径50.0mまで……………4.1t
- 45.5m+4.4m+54.0mHL (45°)
最大作業半径80.0m時……………1.8t

機動性と安定性の両立 KATOキャリヤ



キャリヤ用エンジンには 【ユニットインジェクタ】を採用。

- 電子制御燃料噴射システムを採用した、クリーンで低燃費、高出力エンジンを搭載。
- ヨーロッパ排出ガス規制 EURO3適合エンジン。

■最高出力

●390kW/1800min⁻¹

■最大トルク

●2400N・m/1080min⁻¹

クレーン用エンジンは 環境に優しく、優れた静音性。



【国土交通省指定低騒音型】

■最高出力

●188kW/1800min⁻¹

■最大トルク

●1079N・m/1400min⁻¹

KATOが独自開発した 6軸クレーン専用キャリヤ。

- 高剛性シャーシフレームにより、作業時の安定性を確保します。

超大型にもかかわらず、コンパクトに設計。 内輪差が極めて小さい常時5軸ステアリングシステム。

- 直角通路幅……… 8.25m (10輪ステアリング) (構内走行姿勢)
- 最小回転半径……… 11.6m

車体姿勢調整機能。

- サスペンションシリンダを伸縮させることにより、現場内の路面の状況に合わせて車体姿勢を前後、左右方向に調整することができます。

安心のブレーキシステム。

- 長い坂道を下る時、リターダ、排気ブレーキ+デンプションブレーキを併用することにより、より安心な走行を確保します。

【サイドサポート】付アウトリガ。

- 張出幅は5段階設定。
サイドサポートの搭載で安定性、剛性をさらに高めています。



快適な居住性がオペレータをサポート キャビン



▲オペレータキャブ

ワイドな視界、操作性に優れたレバー配置。 快適さ重視のオペレータキャブ。

- 操作レバーの配置はラフターと共通。各種スイッチは操作し易く、モニターは見やすい位置に配置しました。
- 油圧パイロット式操作レバーを採用し微操作から高速操作までスムーズな操作性を可能にしました。
- オペレータキャブは0°~15°までチルト可能。上方、左右どちらをみてもワイドな視界。ロングブーム作業に欠かせないチルト式キャブ。上方視界を確保して安全で快適な作業を約束します。



▲15°までのチルト式。スライド式ステップの採用でキャブへの乗り込みが楽になりました。



▲走行時の視界も良好・キャリヤキャブ

最先端の安全性を実現

ACSコンピュロードを搭載。

- 定評のあるカラーディスプレイ式ACSコンピュロードを採用。大型画面により、作業状態や安全状況などの情報を同時に一画面に見やすい形で表示できます。
- 作業範囲制限機能など多彩な機能を有します。



リモートコントロール式の明るい作業灯で 夜間作業も安全。

- ブームの先端部に指向性に優れた、明るい大型の作業灯を採用。夜間作業も安心です。
- 操作はキャブから簡単に行えます。



▲リモコン式作業灯